



Attachment R8

Water Management Plan

Vista Gold Australia Pty Ltd

**Mount Todd Project Area
January 2022**



Table of contents

1	Introduction.....	1
1.1	Purpose.....	1
1.2	Guidelines.....	1
1.3	Current Conditions.....	1
2	Surface Water.....	3
2.1	Location.....	3
2.2	Surface Water Catchments and Creeks.....	3
2.3	Water Management Strategy.....	7
2.4	On-site Catchments and Retention Ponds.....	7
2.5	Raw Water Dam.....	15
2.6	Stormwater Management.....	16
2.7	Diversion Drains.....	19
2.8	Surface Water Management Infrastructure and Features.....	21
2.9	On Site Water Use.....	31
3	Groundwater.....	33
3.1	Groundwater Model Results Mining-phase (Tetra Tech 2019).....	33
3.2	Groundwater Demand.....	36
3.3	Groundwater Management Infrastructure/Features.....	37
3.4	Management Measures.....	40
4	Water Account.....	42
4.1	Water account.....	42
4.2	Water account for operations.....	43
4.3	Water account for mining operations.....	43
4.4	Water extraction licence.....	43
5	Risk Management.....	44
5.1	Identify Hazards and Rank Risks.....	44
5.2	Actions and Strategies in Response to Identified Risks.....	45
6	Management.....	54
6.1	Management of Issues.....	54
6.2	Surface Water Management Issues.....	54
6.3	Groundwater Management Issues.....	55
6.4	Remedial or Corrective Management Actions.....	56
7	Proposed Actions.....	59
7.1	Surface Water Management for Operations.....	59
7.2	Groundwater Management During the Upcoming Period.....	62

8	Monitoring.....	63
8.1	Monitoring Programs.....	63
8.2	Surface Water Monitoring	63
8.3	WTP Discharge	68
8.4	Groundwater Monitoring	68
8.5	Meteorological Monitoring.....	74
9	Monitoring Program - Quality Assurance and Quality Control	75
9.1	Data Quality Indicators.....	75
9.2	Summary of Data Quality Acceptance Criteria	76
9.3	Field Program.....	76
10	Data Review and Interpretation.....	78
10.1	Surface Water	78
10.2	Groundwater	85
10.3	Macroinvertebrate Monitoring	92
10.4	Sediment Monitoring	94

Table index

Table 2-1	On-site Catchment areas	7
Table 2-2	Water infrastructure.....	9
Table 2-3	Site-Wide Water Management Flow Summary	11
Table 2-4	Water Management Rules during Operations.....	18
Table 2-5	Expected WTP Effluent Quality (MMP Appendix A13)	22
Table 2-6	Preliminary Pipe and Pump Requirements for Operations	30
Table 3-1	Groundwater Bores	39
Table 5-1	Identified Hazards Relevant to Water Management	45
Table 5-2	Actions and Strategies in Response to Identified Hazards	47
Table 7-1	Annual water transfers and monitoring procedure: Care & Maintenance	60
Table 7-21	Annual water transfers and monitoring procedure: Operations	61
Table 8-1	Surface Water Monitoring Locations - Operations	63
Table 8-2	Surface water physical and chemical parameters	64
Table 8-3	TARP for SW4 non-compliance	67
Table 8-4	Monitoring Bores for Operations	69
Table 8-5	Bore Grouping for operation.....	71
Table 8-6	Groundwater physical and chemical parameters.....	72

Table 8-7 TARP for groundwater.....	73
Table 9-1 Data Quality Acceptance Criteria	76
Table 10-1 Water quality trends 2013 -2021	78
Table 10-2 SW4 Exceedances July 2020 – June 2021	78
Table 10-3 Exceedances recorded at SW4 during discharge December 2020 - March 2021.....	80
Table 10-4 Batman Pit Water Quality 2020/21	81
Table 10-5 SW2 Water Quality.....	83
Table 10-6 Groundwater trend analysis	86

Figure index

Figure 2-1 Local Watercourses	5
Figure 2-2 On-site catchments, creeks and rivers.....	6
Figure 2-3 Catchments and Diversion Drains	8
Figure 2-4 Surface Water Management.....	10
Figure 2-5 Proposed potable water treatment plant.....	16
Figure 2-6 WTP Process	23
Figure 2-7 WTP General Arrangement	24
Figure 2-8 Modelled 100-year ARI Flood Extent.....	26
Figure 3-1 Predicted groundwater inflows to Batman Pit.....	34
Figure 3-2 Modelled changes in water levels at observed levels.....	35
Figure 3-3 Predicted stream flows during mining phase	36
Figure 3-4 Bore Location Map.....	38
Figure 4-1 Site Conceptual Mine Water Discharge Model.....	42
Figure 6-1 Evaporation Infrastructure.....	58
Figure 8-1 Surface Water Sampling Locations.....	66
Figure 8-2 Groundwater Monitoring Bores	70
Figure 10-1 Total aluminium Group 1.....	87
Figure 10-2 Group 1 Total nickel.....	87
Figure 10-3 Group 2 Barium.....	88
Figure 10-4 Group 3 Ammonia.....	88
Figure 10-5 Group 3 EC	89
Figure 10-6 Group 3 Sulfate	89

Figure 10-7 Group 4 Ammonia	90
Figure 10-8 Group 4 Strontium.....	90
Figure 10-9 Group 4 Sulfate	91
Figure 10-10 Group 1 Water Levels	91
Figure 10-11 Group 2 Water Levels	92
Figure 10-12 Group 3 Water Levels	92

Appendices

- Appendix P1 Groundwater data
- Appendix P2 Water Extraction Licence

Abbreviations

AAPA	Aboriginal Areas Protection Authority
AHD	Australian Height Datum
AMD	Acid Metalliferous Drainage
ANC	Acid Neutralising Capacity
DITT	Department of Industry, Tourism and Trade
DME	Department of Mines and Energy
DPIR	Department of Primary Industries and Resources
DO	Dissolved Oxygen
DP	Discharge Plan
EC	Electrical Conductivity
ELN	Exploration Lease Number
EPA	Environmental Protection Agency
GL	Gigalitres
HDPE	High Density Polyethylene
HLP	Heap Leach Pad
Km	Kilometres
L/s	Litres per Second
LGO	Low Grade Ore
PAF	Potentially Acid Forming
Mg/L	Microgram per Litre
MLN	Mineral Leases Number
MMP	Mining Management Plan
NT	Northern Territory
ROM	Run of Mine
RP	Retention Pond
TSF	Tailing Storage Facility
Vista Gold	Vista Gold Australia Pty Ltd
VSD	Variable Speed Drive
WDL	Waste Discharge Licence
WRD	Waste Rock Dump
WMP	Water Management Plan
WTP	Water Treatment Plant
°C	Degrees Celsius

1 Introduction

The Mount Todd Project Area (MTPA) is located approximately 55 km Northwest of Katherine, in the Northern Territory (NT). Since 2007, Vista Gold Australia Pty Ltd (Vista Gold) has managed the MTPA on behalf of the Northern Territory Government. The site was previously mined for gold during the 1990s before its closure in 2000. The site is planned to transition from care and maintenance to operational and as such, this document provides the basis for water management on and off site when the site commences operations.

1.1 Purpose

This Water Management Plan (WMP) is required for the MTPA to proceed to an operational phase as water management is an integral part of managing the mine site and its interaction with the surrounding environment. This WMP has been developed to provide effective water management strategies and activities that will be undertaken for the MTPA. The intention of the WMP is to support the activities of the Mine Management Plan (MMP). Annual updates to the WMP will be required to reflect any changes in management policy, regulatory requirements (e.g. the application of a Waste Discharge Licence (WDL)) and site conditions that may occur in the previous year.

This Plan forms part of the Environmental Management System (EMS) for the MTPA and is considered a working document. This Plan has been updated following formal assessment by Department of Primary Industry and Resources (DPIR, now the Department of Industry, Tourism and Trade (DITT)) as part of the mining authorisation process.

1.2 Guidelines

The WMP has been developed with reference to the DITT, Northern Territory Environmental Protection Authority (NT EPA), Department of Environment, Parks and Water Security (DEPaWS) and the Australian and New Zealand Governments (ANZG 2018) guidelines including:

- Template for the Preparation of a Mining Management Plan. NT Mining Management Act. (Department of Mines and Energy, Northern Territory Government);
- Australian and New Zealand Guidelines for Fresh and Marine Water Quality (ANZG 2018);
- Australian Guidelines for Water Quality Monitoring & Reporting (ANZG 2018¹);
- Australian Drinking Water Guidelines (NHMRC/ARMMC) (2011, updated August 2018);
- Assessing and Managing Water Quality in Temporary Waters (ANZG 2020); and
- Guidelines for Groundwater Protection in Australia (ANZECC/ARMCANZ, 2013).

1.3 Current Conditions

The MTPA experiences a tropical climate characterised by a hot, humid wet season from October to March, followed by a hot, dry season from April to September. The seasonal tropical climate results in alternating extremes of creek flows, from prolonged dry periods of no flows, to

¹ <https://www.waterquality.gov.au/guidelines/anz-fresh-marine>

substantial flood events in the wet season. Therefore, with this climatic situation the water management system needs to manage the large fluctuations in water volumes between each season.

The MTPA currently contains several water bodies with lower than ambient pH and associated high metal concentrations attributed to past mining activities. These water bodies include:

- Waste rock dump repository (RP1)
- Tailings dam (TSF1)
- Retention Pond 5 (RP5), RP5 is the existing sediment trap that will no longer be required once the proposed operations commence
- Heap leach facility (HLP)
- Low grade ore dump pump sump (RP2)

Currently, the major source of acid metalliferous drainage (AMD) generation is the seepage from the Waste Rock Dump (WRD), which drains into Retention Pond 1 (RP1), resulting from precipitation on the exposed sulphide rock in the WRD during the wet season. The Batman Pit contains treated mine water that is maintained in-situ. No water (treated or untreated) is currently actively or passively discharged from these water bodies from site.

The current water management strategy is a combined effort of on-site storage and water movement into Batman Pit which aims to reduce the potential for an uncontrolled release of AMD from RP1 entering the receiving environment. All current water management activities are the subject of and have current DITT approval.

Once the site transitions from care and maintenance to operational the overall water balance is expected to be in deficit due to the projected water resource requirement for the ore processing facility and mining operations. Therefore, discharge of water containing elevated levels of heavy metals and/or low pH to the receiving offsite environment is unlikely to be required in normal climate conditions, and only treated water from the water treatment plant will be actively discharged from site if required.

2 Surface Water

2.1 Location

2.1.1 Edith River

The MTPA is located within the Daly River Catchment. The Edith River is located directly to the south of the mine site and intersects Mineral Lease Number 1127 (MLN 1127). An overview of the receiving environment is provided in **Figure 2-1**. The Edith River is fed by several ephemeral creeks, five of which run through the MTPA (detailed in **Section 2.2**) and currently receive the rainwater runoff from site related catchments within the mineral leases. The river intersects the mine site to the south and flows from east to west. The volume of runoff from site related catchments has typically contributed less than 50% of the total flow within the Edith River at SW4 (current compliance location for water quality).

The Edith River enters the Fergusson River approximately 15 km to the northwest of the mine site.

The Edith River has a high ecological and recreational value as the site is located approximately 9 km downstream of Leliyn/Edith Falls which is situated within Nitmiluk National Park. This WMP for the MTPA introduces management to minimise any potential risk to the Edith River system by eliminating the discharge of treated water from the site, both in the care and maintenance phase and during operations.

2.2 Surface Water Catchments and Creeks

The Edith River is situated within the Daly River catchment, one of the largest river systems in the Northern Territory with a catchment area of 52,577 km². Five ephemeral creeks flow through the mine site prior to entering the Edith River:

- Batman Creek
- Horseshoe Creek
- Stow Creek
- Burrell Creek
- West Creek

Horseshoe and Batman creeks enter Stow Creek prior to its discharge to the Edith River. **Figure 2-2** and **Figure 2-3** show the locations of these creeks and rivers, and their relevant catchments.

2.2.1 Batman Creek

Batman Creek originates from a natural catchment area up-stream to the west of the site. The creek captures surface runoff from uncontaminated areas through the site. From 2013 to 2021, Batman Creek received the treated mine water discharged from Batman Pit, in accordance with the rescinded WDL 178.

2.2.2 Horseshoe Creek

Horseshoe Creek originates from a natural catchment to the north of TSF1. It also contains flows originating from the raw water supply reservoir and the diversion channel northwest of TSF1, as

shown in **Figure 2-3**. A small quantity of mine water has the potential to enter Horseshoe Creek year-round via seepage points near the southern and eastern embankments of TSF1.

2.2.3 Stow Creek

Stow Creek is an ephemeral watercourse with a large catchment to the east of the site measuring 25.1 km in length. Batman Creek and Horseshoe Creek enter Stow Creek within the mine lease.

2.2.4 Burrell Creek

Burrell Creek is an ephemeral creek, with the lower reaches classified as seasonal wetlands as it contains wetland vegetation during the wet season. The WRD and RP1 cover the majority of the natural creek and catchment. The major source of flow is from surface runoff due to rainfall during the wet season. Currently there is potential for seepage from RP1 to enter Burrell Creek, however the proposed modifications of RP1 and Batman Pit for water to be redirected to the process water pond to provide water for the mining operations process water supply will reduce the potential for seepage inputs to Burrell Creek

2.2.5 West Creek

West Creek is ephemeral and is located to the west of the Batman Pit and RP1. West Creek receives surface water flows from the natural catchment in the southwest of the site and from the western stormwater diversion drain.

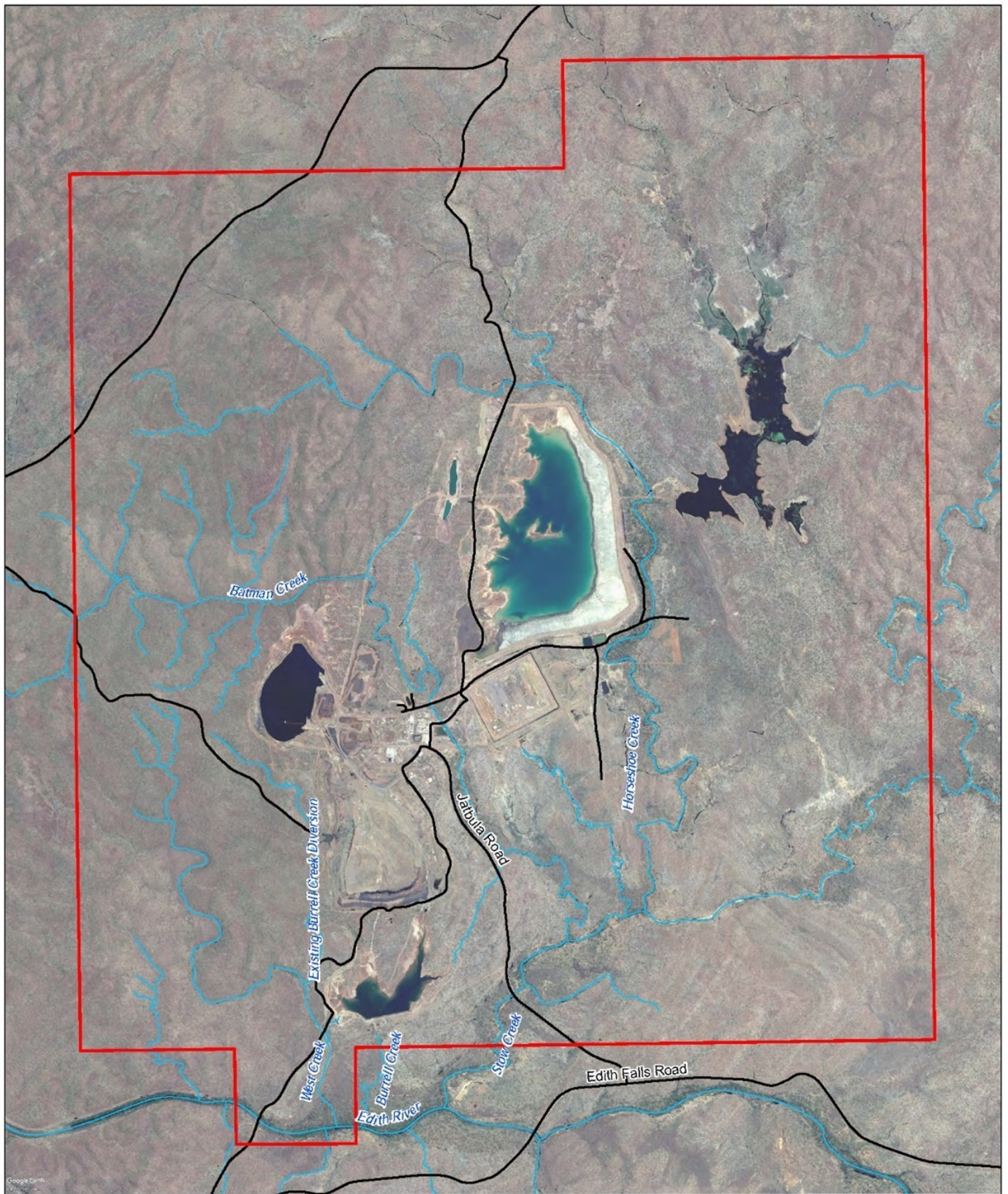

- LEGEND**
-  Roads
 -  Waterways
 -  Mt Todd Mineral Leases

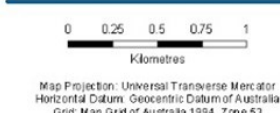

Map Projection: Universal Transverse Mercator
 Horizontal Datum: Geocentric Datum of Australia
 Grid: Map Grid of Australia 1994, Zone 53



Vista Gold Australia Pty Ltd
 Mt Todd Gold Project

Job Number | 43-22632
 Revision | 0
 Date | 19 Jun 2017

Local Watercourses

Figure 2-1

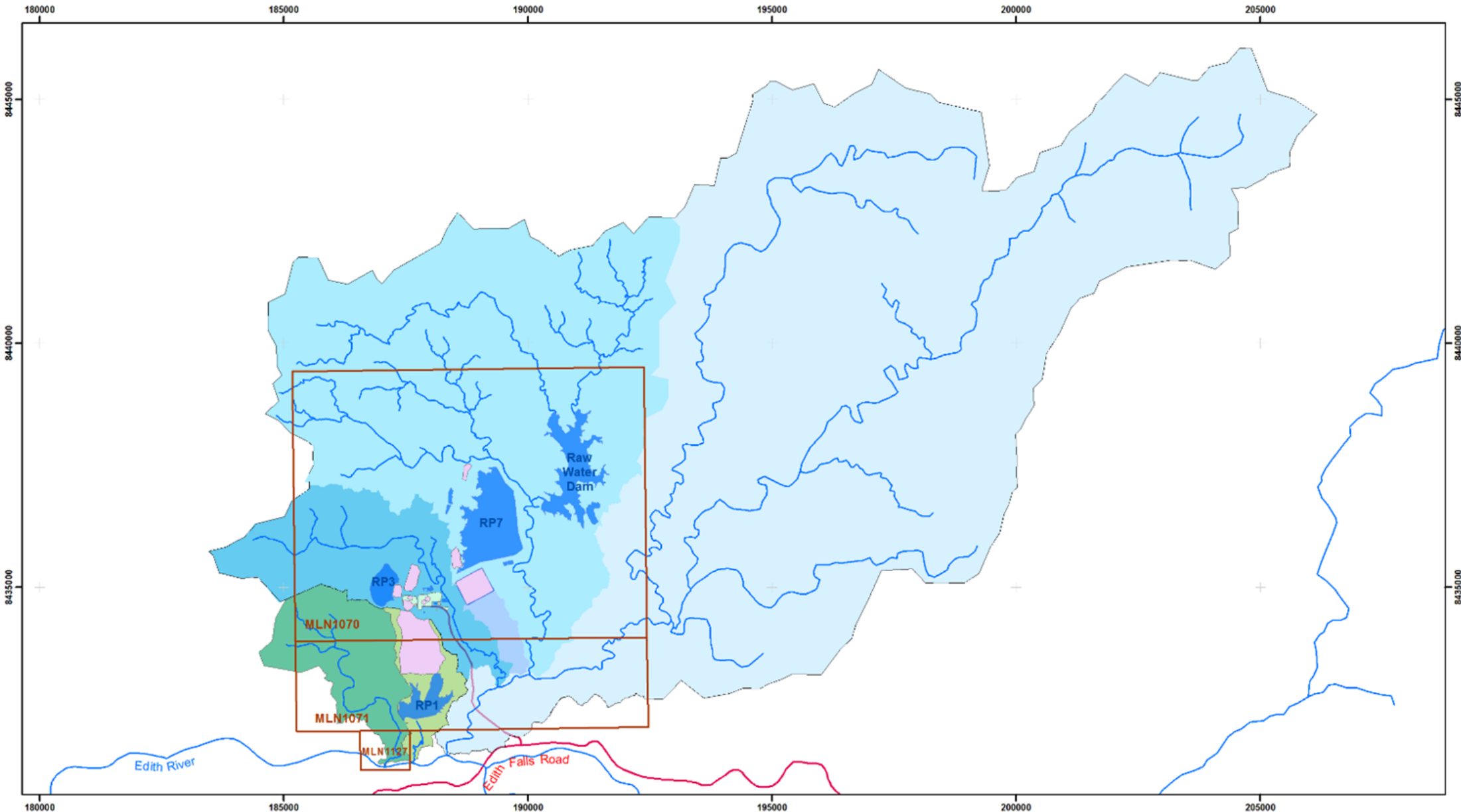

- Legend**
- Mineral Leases
 - Creeks & Rivers
 - Plant and administration area
 - Catchments**
 - Burrel Creek
 - Horseshoe Creek
 - West Creek
 - Retention Ponds
 - Stockpiles
 - Batman Creek
 - HLP Drain
 - Stow Creek
 - Sealed Roads

Map Projection: Universal Transverse Mercator
 Horizontal Datum: Geocentric Datum of Australia
 Grid: Map Grid of Australia 1994, Zone 53
 Revision:0 Date:6/4/203 Map By: A Brandis

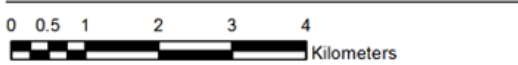

Primary catchments areas Figure 2-2

Vista Gold Australia Pty Ltd
Mt Todd Gold Project

EnviroTech Monitoring makes every effort to ensure this map is free of errors but does not warrant the map or its features as either spatially or temporally accurate beyond its intended general reference use. This map is provided without any warranty of any kind whatsoever, either express or implied.

2.3 Water Management Strategy

The previous surface water management strategy was successfully designed to reduce the on-site water inventory. The water in Batman Pit had undergone treatment and was pumped to the Edith River at volumes based on the water chemistry of Batman Pit and the flow in the Edith River. Currently, all on-site water runoff is managed to prevent the likelihood of poor-quality water entering the natural waterways on-site.

During operations all onsite surface water runoff will be directed to the process water pond (PWP) which will provide the ore processing plant with process water. Excess surface water runoff not required for mine operations during the wet season will be treated by the water treatment plant and discharged to the Edith River via Stow Creek. Any treated water discharged from site will be of sufficient quality to meet WDL requirements at SW4. **Figure 2-3** shows the proposed water management during operations.

2.4 On-site Catchments and Retention Ponds

2.4.1 On-site catchments

The site contains numerous retention ponds each with a contributing catchment area. The pond waters have historically contained variable concentrations of dissolved metals and have had low pH levels. During the wet season, the high levels of precipitation result in the generation of AMD from the WRD (exposed sulphide rock). AMD will be managed with the commencement of mining and process operations by targeted encapsulation of PAF materials and historical AMD runoff will be managed through diversion to the process water pond (PWP) which will be pH modified for integration into the process water circuit. There are also a number of smaller ponds, which do not have definable catchments which will be decommissioned, or their flows will be directed to the PWP. Therefore, the catchments of PRP, RP2 and the HLP will all contribute to the catchment of the PWP.

The mine site's current internal surface water flows consist of six primary catchments each of which feed surface water runoff into its corresponding retention pond, as shown in **Figure 2-3**. **Table 2-1** lists these catchments with their surface areas as they currently exist and **Table 2-2** details the size of each retention pond.

Table 2-1 On-site Catchment areas

Catchment	Area (ha)
RP1	145
RP2	32
Batman Pit	57
PWP	33
TSF1	75
TSF2	296
TOTAL	638

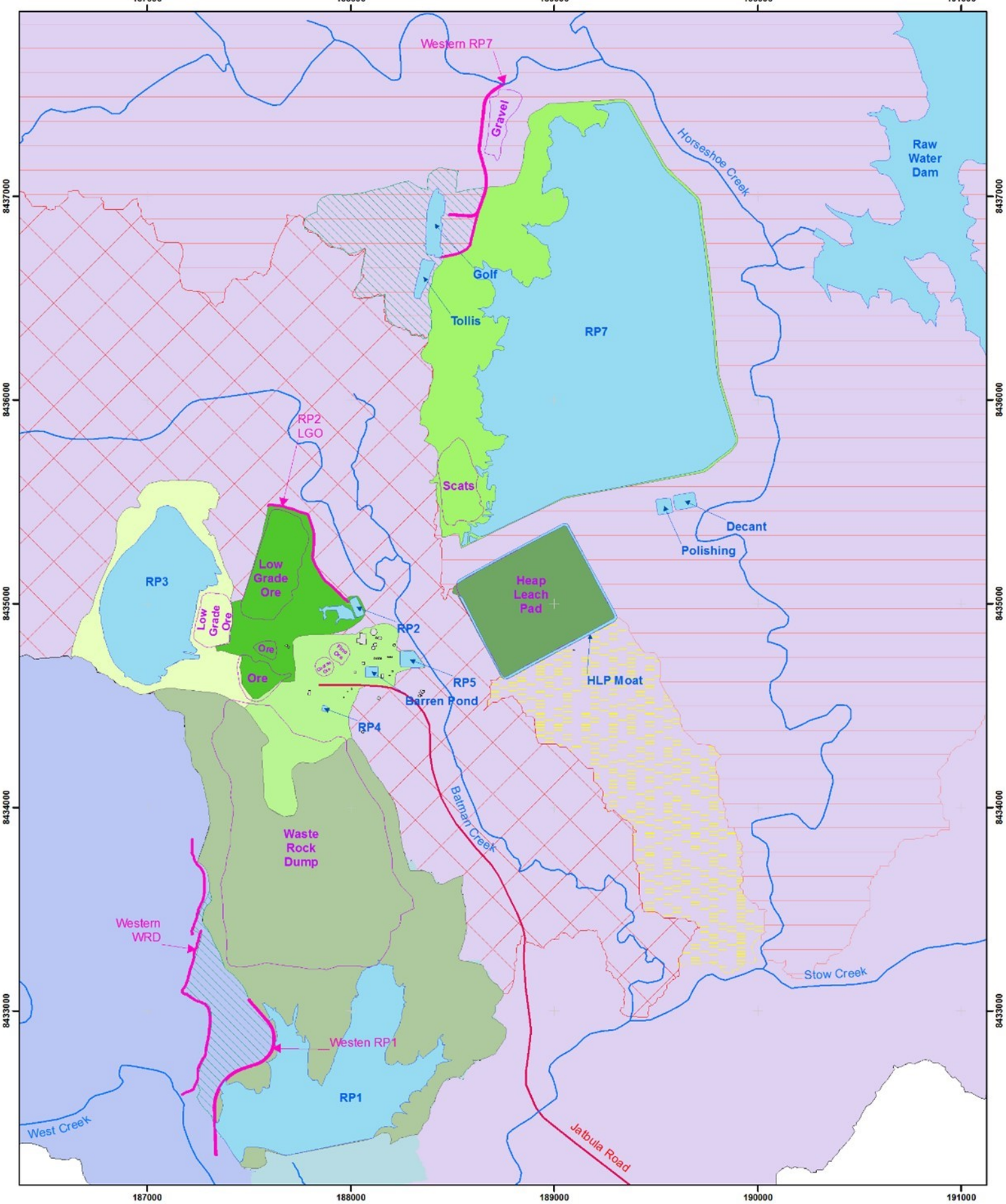

Legend

Retention Ponds	Facilities	Diversion Drains	RP Catchments	RP1	RP2	HLP Catchments	West Ck	Horseshoe Ck	Stow Ck
Creeks & Rivers	Stockpiles	Sealed Roads	Diverted	RP3	RP5	HLP Moat	Batman Ck	HLP Drain	

Map Projection: Universal Transverse Mercator
 Horizontal Datum: Geocentric Datum of Australia
 Grid: Map Grid of Australia 1994, Zone 53
 Revision:0 Date:6/4/203 Map By: A Brandis

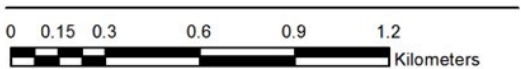

Figure 2-3 **Onsite catchments and Diversions**

Vista Gold Australia Pty Ltd
 Mt Todd Gold Project

Envirotech Monitoring makes every effort to ensure this map is free of errors but does not warrant the map or its features as either spatially or temporally accurate beyond its intended general reference use. This map is provided without any warranty of any kind whatsoever, either express or implied.

2.4.2 Retention ponds

Detailed below are the retention ponds on site and water management infrastructure, considered in water management planning and activities. There are also a number of smaller ponds without catchments; these ponds are not considered in water management operations or planning, as these ponds do not require active management. A further six catchments are present within the site; these are natural catchments, which drain undisturbed runoff directly in the various creeks which dissect the site, as shown in **Figure 2-2**. **Figure 2-4** shows the water management at the site during operations.

Table 2-2 Water infrastructure

Storage Structure	Retention Pond Number	Maximum Storage Capacity (m ³)	Maximum pump rate (m ³ /hr)	Pump to
Waste Rock Dump Retention Pond	RP1	1,226,548	443	PWP
Low Grade Ore Stockpile Pond	LGRP (formerly RP2)	10,414	266	PWP
Batman Pit	BATMAN PIT (formerly RP3)	11,970,286	443	PWP
Process Plant Retention Pond	PRP (formerly RP5)	13,721	70	PWP
Process Water Pond	PWP	72,000	500	WTP
Treated Water Holding Tank	TWHT	300	300	PWP, Edith River
Tailings Storage Facility	TSF1	4,680,000	182.5	PWP
Tailings Storage Facility	TSF2	TBA	182.5	PWP
Heap Leach Pad Moat	HLP	1,134	194	PWP
Raw Water Dam	RWD	Infinite	284.5	Process Plant
Water Treatment Plant	WTP	-	500	Process Plant, Dust suppression, discharge
Process Plant	PP	-	-	PRP, PWP

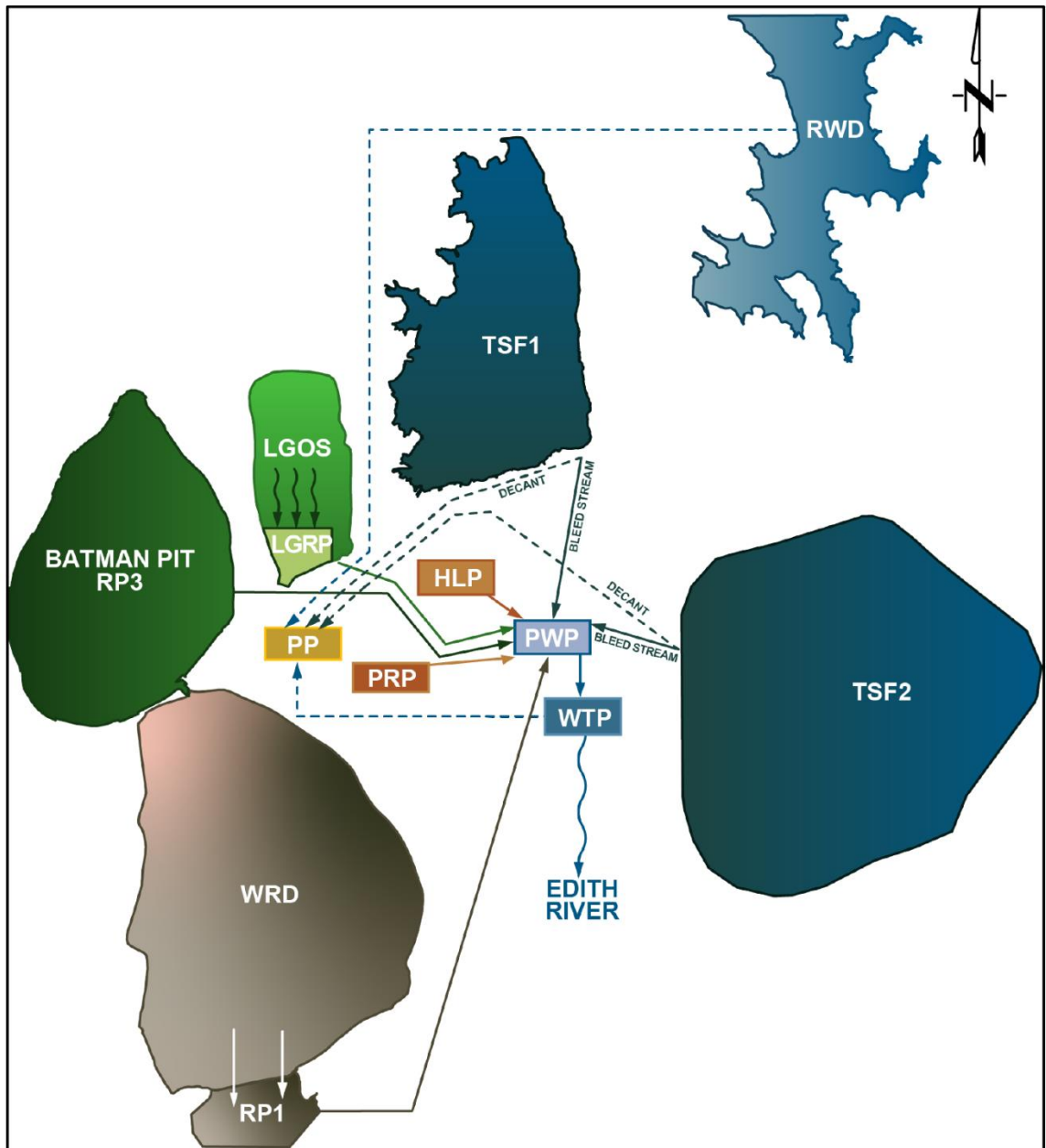

Figure 2-4 Surface Water Management

Table 2-3 Site-Wide Water Management Flow Summary

Landforms/ Impoundments	Modeled Volume (m ³)	Pump/Report to Location(s)	Maximum Pump Rate to Pump to Location (m ³ /hr)	Years when Maximum Pump Rate Observed	Wet Season Estimated Average Flow (m ³ /hr)*	Dry Season Estimated Average Flow (m ³ /hr)*
Tailings Storage Facility 1 (TSF1)	4,156,231	PP, PWP	2,270, 250	1-14	933, 0	972, 125
Tailings Storage Facility 1 Seepage Pond	NA	TSF1	75	2-8	43	43
Tailings Storage Facility 2 (TSF2)	4,945,772	PP, PWP	2,270, 250	3-17	1144, 0	1150, 125
Tailings Storage Facility 2 Seepage Pond	NA	TSF2	160	17-19	68	69
Raw Water Dam (RWD)	18,325,000	PP	750	1-17	181	266
Low Grade Ore Stockpile (LGOS)	NA	Seepage/runoff reports to LGRP	No Pumping	NA	NA	NA
Low Grade Ore Stockpile Retention Pond (LGRP)	17,072	PWP	450	1-17	105	14
Heap Leach Pad Moat (HLP)	45,030	PWP	194	1-17	102	15
Batman Pit (RP3)	11,970,286-327,656,639	PWP, Dust Suppression	750, 50	1-15	182, 9	37, 10
Process Plant Retention Pond (PRP)	9,536	PWP	70	1-17	16	10
Waste Rock Dump (WRD)	NA	Seepage/runoff reports to RP1	No Pumping	NA	NA	NA
Waste Rock Dump Retention Pond (RP1)	1,200,196	PWP	600	1-18	236	97
Process Water Pond (PWP)	185,394	WTP	600	1-17	566	397
Water Treatment Plant (WTP)	NA	Edith River, Process Plant, Dust Suppression	600, 600, 50	1-17	302, 61, 3	33, 156, 19
Process Plant (PP)	NA	TSF1, TSF2	2,547	1-17	1273.5, 1273.5	1273.5, 1273.5

NOTES:

NA – not applicable; *monthly average flow

** lower due to priority of pumping logic to PWP

2.4.2.1 **RP1**

RP1, located within the Burrell Creek catchment, was initially constructed for the purpose of water supply for prior operations and to contain the WRD runoff. RP1 was constructed during previous operations for water supply and WRD runoff containment and is situated in the Burrell Creek catchment. The RP1 catchment stretches to the north and encompasses the WRD. 42% of the RP1 catchment is covered by the current WRD, the proposed WRD will cover the entire RP1 catchment and part of RP1. To extend the size of the WRD into RP1, three cofferdams will be constructed along the southern toe of the WRD (Appendix A 14 – Stormwater Management Plan). The runoff from the future 217 ha WRD will be captured in RP1 and the coffer dams will allow the water infiltrating the WRD to drain out. To maintain the storage capacity of RP1 the depth of RP1 will be increased.

At present, RP1 is exclusively an AMD containment pond, however during operations it will also be a source of water for the processing plant, via the WTP. RP1 is unlined facility with a clay and earthen wall. The quality of water within the pond is and has been historically poor with high metal contents and low pH ranges. More detailed information regarding RP1 can be found in **Section 6**.

The current spillway at RP1 has a height of 120.26 m and comprises a concrete core surrounded by earth and rock armouring with gravel capping. RP1 contains a 45 m wide spillway on the south-western corner, which, historically permitted excess water to flow into West Creek. However, this has been addressed and uncontrolled discharges from RP1 to West Creek no longer occur.

Modelling of RP1 suggests the maximum pond storage level is 1,255 ML. The water level in RP1 is monitored to maintain maximum freeboard to avoid uncontrolled discharges and excess water is currently pumped to Batman Pit for containment and during operations it will be pumped to the PWP. Due to the larger WRD as detailed design progressed from PFS to FS the footprint of RP1 was consumed and an alternate location South of the existing RP1 will be established. This will be done in concert with the Jawoyn People and is expected to be a smaller surface area than the one that has been previously proposed (it will likely be deeper to maintain a similar volume).

2.4.2.2 **Low Grade Ore Stockpile Pond**

Situated immediately to the north of the old processing facilities, this pond's primary purpose is to capture AMD runoff from the LGO stockpiles to allow pumping to the PWP). The LGRP catchment is limited to the extent as shown in **Figure 2-3**, however, during heavy downpours the spillway has the potential to discharge excess water northward prior to entering Batman Creek, however, LGRP is currently actively managed to avoid this scenario. During operations this will be managed so that all surface water runoff will divert to the PWP and the spillway will be lined with HDPE to preclude the infiltration of acidic runoff in the channel.

2.4.2.3 **Process Plant Retention Pond (RP5)**

The PRP will replace RP5, however, in addition the PWP will act as the collection point for all surface water runoff and overflows from the RPs. Water will be removed from the PRP by pumping to the PWP and via evaporation. The PRP may be allowed to send water directly to

the process plant following a heavy rainfall event. This mechanism is not in place within the current site-wide water balance (SWWB) but is proposed for future versions (Appendix A9).

2.4.2.4 Process Water Pond

The PWP catchment will encompass the mine processing and operational facilities, the southern faces of the ROM pad and the surface runoff from the access ramps and roads on the WRD. The PWP will be a lined facility to collect runoff from the plant and processing area (RP2, HLP and WRD). Also, water from TSF1, TSF2, RP1, LGOs, processing plant Batman Pit and the water treatment plant (WTP) (if required as top up water). The PWP is located to the east of the processing area all of which is situated within in the Batman Creek catchment. Water not used in the ore processing plant will be treated by the WTP prior to discharge via Stow Creek to the Edith River or other use on site. During heavy rainfall the WTP will manage water quality discharge.

2.4.2.5 Batman Pit

Since the termination of operations in 2000, Batman Pit has been the end point for pumped excess water from the various other on-site retention ponds. This strategy was used to prevent uncontrolled discharges of poor quality mine water from the site. Prior to 2012, Batman Pit contained poor quality water due to high metal concentrations and low pH. The water quality significantly improved since 2012 due to the micronized minerals treatment process which allowed dewatering from the pit and discharge to the Edith River.

An important feature of the current water management strategy is to maintain the Batman Pit water level below the identified brecciated zone where there is potential for connectivity between the pit water and the groundwater. Currently the level of water in Batman Pit is below this level, and due to dewatering activities, it is unlikely that the water level will rise to this zone. During operations any surplus water pooling in the pit will be pumped to the PWP.

Prior to the 2015-16 wet season an additional lime treatment was applied to Batman Pit to further treat the water body and to reduce the required dilution ratio for offsite discharges. An additional 158 tonnes of lime was added to Batman Pit in December 2015 to precipitate the metals in the upper layers and by late January 2016, a dilution rate of 1:24 was achieved which had been maintained unto 2020. By March 2021, the volume in Batman Pit had reduced to 0.47 GL and active discharge of treated pit water ceased. As the site was no longer discharging treated water WDL 178-08 was rescinded by DEPaWS.

2.4.2.6 TSF 1

Currently, the existing tailings storage facility dominates the TSF1 catchment. 72.5% of incident rainfall falls directly into the TSF. The majority of natural inflows are surface water runoff and rainfall with a small amount of AMD that is generated by the scats stockpile to the west, which is contained within the TSF. The proposed operational program will reprocess the scats stockpile via the new processing facility and thereby reduce the AMD loading to TSF1.

TFS1 is located in the Horseshoe Creek catchment and is not a specifically designed water storage facility. It is designed to be a process tailings storage facility and is the last place to send water only if all other water storage areas are full. The emergency spillway is located at the south-western corner and is comprised of a canal formed into the siltstone, which carries water

around to the southern channel between TSF1 and the HLP. Water quality within TSF1 is poor, primarily due to the storage acting as a receptacle for site AMD waters since operations ceased in 2000, and to a smaller extent, due to AMD runoff from the scats stockpile in the south-western corner of the catchment.

The supernatant water has a low pH and the highest dissolved metal content of all ponds. The tailings pore water still largely exhibits a process water signature and despite the acid neutralising capacity having been exhausted in the top 1.2 m, sufficient ANC remains below the acidic wedge. As a result of its operation as a secondary water storage facility, the high-water levels within TSF1 have had the benefit of minimising acidity generation from oxygen exposed unsaturated tailings.

TSF1 will be reinstated as a TSF when mining operations commence and prior to the commissioning of a new Tailing Storage Facility (TSF2) which will involve reversing the pH back to the 10 – 11 range. At high pHs, most metals will be trapped in the tailings and not in the water, it is anticipated that any water released will be pH neutral or neutralise rapidly upon release reducing the solubility of metals. Vista Gold will undertake a TSF1 expansion consisting of six separate embankment raises and construction of two saddle dams for tailings storage within the impoundment. The final design will result in an elevation of 169m. This increase in elevation will reduce the potential for uncontrolled discharges from the TSF with additional management of transferring water to Batman Pit and thus lowering the freeboard if required.

To mitigate the presence of the natural (pre-development) Horseshoe Creek watercourse beneath the northeast section of TSF1 a drainage network exists for the effective management of seepage. Horseshoe Creek currently flows through a diversion around the structure. However, seepage does occur from TSF1 where the structure crosses over the pre-existing creek lines. These seeps and a number of others present visibly at the surface. To manage this seepage, the return water from the decant towers and the seepage collected within the underdrain system and upstream toe drain will flow to the lined return water pond located at the southeast corner of the TSF1 embankment prior to the water being transferred to the equalisation pond and reused in the processing plant.

The emergency spillway is currently located at the south-western corner and is comprised of a canal formed into the siltstone, which carries water around to the southern channel between TSF1 and the HLP. However, after the expansion, this will no longer be a part of the TSF infrastructure. An overflow spillway will be constructed at the crest of the proposed south saddle dam. The spillway shall be raised with each subsequent embankment raise.

The expansion of TSF1 will enable 112.5 million tonnes of thickened tailings to be contained at a nominal rate of 50,000 tpd (Section 4.6.1 of the MMP). This expansion will occur in a eleven-stage process.

2.4.2.7 TSF2

The proposed TSF2 will be constructed east of the Batman Pit using a staged upstream construction technique. To minimise seepage to groundwater, the TSF2 impoundment has been designed with a 1.5 mm 60-mil linear low-density polyethylene (LLDPE) textured (double sided) geo-membrane bottom liner for tailings containment. The LLDPE liner will be underlain by a geosynthetic clay liner (GCL) as liner sub-base. An underdrainage system consisting of gravel

drains has been designed under the base liner to collect groundwater inflows from areas upstream of TSF2. The primary under-drain will collect flows from a series of secondary gravel under-drains. Seepage flows from the primary under-drain will be collected in two separate underdrain seepage collection sumps located at the southwest corner of TSF2. The water quality of the seepage collected in the under-drain seepage collection sump will be monitored regularly and the water transferred to the Equalisation Pond or to the supernatant pond atop TSF2 during operations.

A network of gravel over-drains has been designed above the liner system to collect pore water drainage from the tailings mass. The drainage from the over-drain system will report to an over-drain seepage collection sump located south of the TSF. Overflow from the seepage collection sump under upset conditions such as a mechanical failure of the pumps, will discharge into the adjoining lined seepage overflow collection pond. The seepage reporting to the collection sump will be pumped to the supernatant pond atop TSF2 during operations.

Supernatant process water from the tailings impoundment will be pumped as return water to the PWP using a pair of skid mounted electric pumps. For more information on TSF2 construction see Section 4.6.2 of the MMP.

2.4.3 Inflow and Seepage

As detailed in the MMP Appendix A 11, groundwater modelling has shown that drawdown of the local aquifer associated with the mine site during operations is not likely to have a significant impact on the local groundwater flows into the Edith River or to neighbouring groundwater supply bores at Werenbun and Leliyn (Edith Falls).

The proposed Batman Pit deepening and enlargement are likely to result in a terminal sink pit lake with a water level significantly below the surrounding land surface. The steady state pit lake water level elevation is predicted to be approximately -15 m AHD. This is expected to prevent outward migration of pit lake water into and through the aquifer.

2.5 Raw Water Dam

The Raw Water Dam (RWD) was built during previous operations is located on Horseshoe Creek and supplies raw water to the MTPA. The RWD will primarily supply water for dust suppression. Untreated raw water will also be distributed to the process plant water circuit, powerhouse, mining facilities, firewater circuit and camp if required. For drinking purposes raw water will be fed from the dam to site and stored in a raw water tank until treatment in a WTP (**Figure 2-5**). Potable water (1.7 m³/h) is treated via filtration, chlorination and ultraviolet sterilisation, then stored in a potable water tank prior to distribution. For the normal operations, the nominal raw water consumption will be 600 m³/h and will occasionally peak at 2,200 m³/h during the dry season.

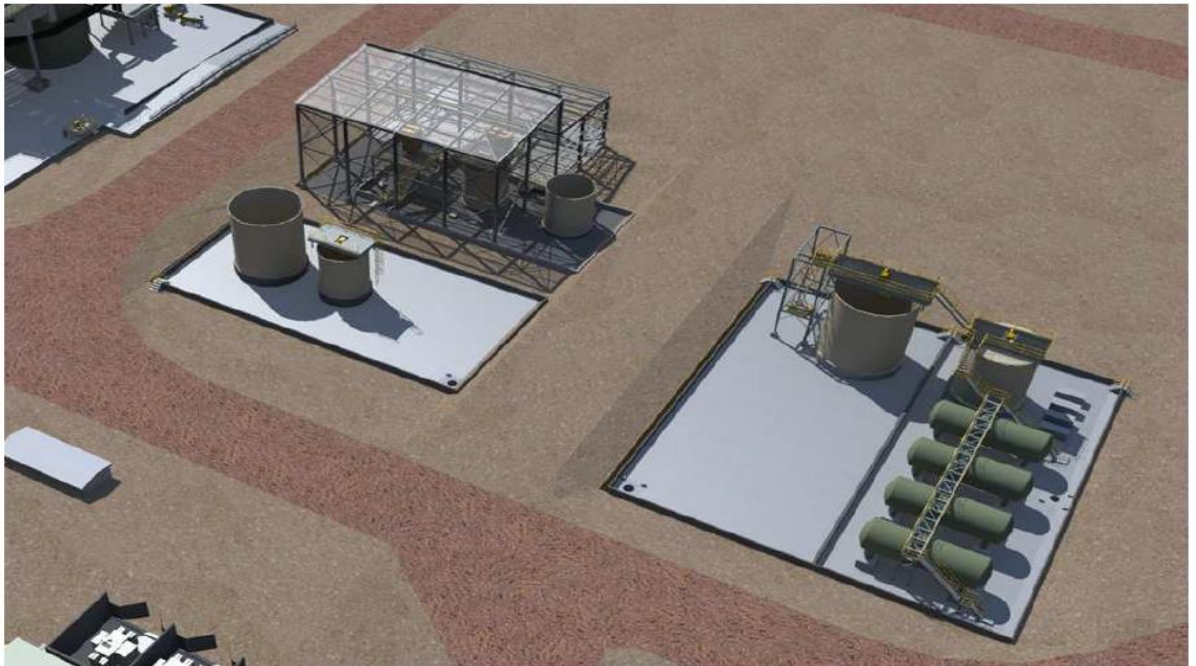

Figure 2-5 Proposed potable water treatment plant

2.6 Stormwater Management

As discussed previously, the MTPA is traversed by five ephemeral creeks which drain into the Edith River, located to the south of the mine. Horseshoe and Batman Creeks feed Stow Creek which borders the proposed TSF2 and then flows into the Edith River. Horseshoe Creek flows along the eastern boundary of the mine, Batman Creek flows through the centre of the mine and Burrell Creek flows along the south-western corner of the MTPA. Burrell Creek will be partially buried by the new waste rock dump (WRD). West Burrell creek flows to the east near the southwest toe of the WRD, where it turns south and drains to the Edith River (see Appendix A14 Stormwater Management Plan Section 4.4).

Flooding along these creeks has the potential to encroach on storage embankments, plant, pit and other infrastructure. Hydrologic modelling in conjunction with 1-D hydraulic models has been used to extend the existing flood outlines from previous studies and to assess flood immunity and impacts on existing and proposed mine infrastructure, particularly storage embankments. Channels have been designed to route the storm runoff away from the mining facilities and to the Edith River. These channels are strategically placed to limit the water interacting with mine facilities and being directed to the WTP for treatment.

Flood modelling has shown that most of the existing mine infrastructure is located outside the 100-year ARI design flood extent of creeks passing through the mine area. The notable exceptions are the future TSF2 which encroaches on the area of flooding along Horseshoe Creek and Stow Creek, also the area of the proposed LGO stockpiles and ROM which encroach on the flood extent of Batman Creek.

The design of TSF2 includes diversion channels and levees along Horseshoe Creek and Stow Creek to protect the embankment from flooding and erosion as shown in Section 4 of the MMP. Diversion channels have been designed for 100-year ARI flood events and comprise lined rip-rap channels with a width and length on Stow Creek of approximately 60 m and 850 m, respectively, and a nominal depth of 4.2 m. The width and length of the diversion channel on Horseshoe Creek will be approximately 40 m and 550 m, respectively, with a nominal depth of 2.5 m.

The existing TSF1 is protected from flooding along Horseshoe Creek by means of a creek diversion channel which modelling shows has sufficient capacity to accommodate the 100-year ARI design flood event.

Upgraded drainage channel designs have been made to route stormwater to the nearest creek to avoid contamination and interference with mining activities. Drainage across the processing plant site will be limited by the installation of cut-off drains to divert uncontaminated runoff from around the site and into Batman Creek via a settling pond. All stormwater runoff from within the site will be directed toward the existing drainage channel on the east side of the proposed process plant.

ROM and additional LGO stockpiles will require collection ditches to capture runoff and seepage from stockpiles for conveyance to the PWP. The designs for the required channel, sedimentation ponds and storage embankment heights for these structures are located in Appendix A14 Stormwater Management Plan.

Mitigation includes diversion structures to limit the runoff from undisturbed areas of the mine and upstream catchments from reaching water containment and plant infrastructure. Diversions are also present upstream of the LGO stockpiles and around the HLP with the purpose of collecting runoff from these disturbed areas of the mine and directing it into storage ponds for transfer to the WTP (or direct to the WTP).

Diversion drains have been constructed around the western and eastern margins of the RP1 to divert uncontaminated runoff away from the pond and reduce the risk of overtopping. Diverted water reports to local creeks downstream of the pond. With the increased size of the WRD new diversion drains have been designed to divert runoff from RP1. Additional diversion ditches have been designed around the east and west of TSF2 and east of TSF1 as to avoid the unnecessary treatment of previously clean water.

Overtopping of cross drainage structures and haul roads is likely to be an infrequent occurrence but upgrades to existing stormwater drainage, erosion and sediment controls, including the vegetation of verges, will be necessary to minimize damage during less extreme but more frequent storm events.

Locations where flood peak velocities are expected to exceed 2m/s and thus have the potential to cause scouring of unlined channels have been identified. Whilst the majority of these locations are sufficiently distant from mine infrastructure to be of no immediate risk, the section of Batman Creek adjacent to the processing plant is likely to experience high velocity flows during extreme flood events. Rip-rap protection to earthwork embankments adjacent to the existing drainage channel on the east side of the proposed process plant will be installed for channel protection. Upstream sections of the Western WRD diversion channel will need rip rap,

sizing for rip rap will be in the details of the drawing for each channel. Sections of Stow Creek in the vicinity of the proposed embankment of TSF2 are also expected to experience high flow velocity during extreme flood events. Scour protection measures will include placement of rip-rap in association with proposed channel diversion works.

The following additional mitigation measures are proposed for the management of storm water runoff:

- Ensure flood immunity by siting mine infrastructure outside the 100-year ARI flood extent;
- The potential for contamination of receiving waters has been reduced by segregation of “clean” stormwater runoff from “dirty” stormwater runoff and the collection and treatment of “dirty” stormwater runoff from areas within the mine site;
- The amount of water in Batman Pit has been reduced by minimising the stormwater runoff entering the pit by construction of bunds around the pit perimeter;
- The amount of stormwater runoff from material stores has been minimised through appropriate design of batter slopes and drainage collection systems;
- During rainfall events that exceed the design capacity of water containment infrastructure, excess inflow may need to be redirected back into the active TSF up to the height of beached tailings or allowed to overflow to the environment. It is assumed that retention ponds have been designed to overflow whilst maintaining the safety of embankment structures.

Table 2-4 Water Management Rules during Operations

Source	Destination	Rule
Burrell Creek	West Creek	WRD will progressively fill to occupy its own catchment thereby replacing catchment runoff with rainfall seepage.
Burrell Creek	West Creek	Runoff from 29 % of catchment and up to 10-year 24-hour storm volume will be diverted in drains around RP1.
WRD Pond (RP1)	WTP	Pump to WTP if PWP freeboard is less than 0.5 m threshold.
Low Grade Ore Stockpile Pond (RP2)	WTP	Pump to WTP if PWP freeboard is less than 0.5 m threshold.
Stormwater Sediment Pond (PRP)	WTP	Pump to WTP if PWP freeboard is less than 0.5 m threshold.
Heap Leach Pad (HLP)	WTP	Pump to WTP if PWP freeboard is less than 0.75 m threshold.
Batman Pit	WTP	Pump to WTP if PWP freeboard is less than 0.5 m threshold
WTP	Batman Creek / Edith River	Discharge water in excess of processing plant and dust suppression requirements via TWHT (pond not modelled in GoldSim).

Source: GoldSim Model MtToddWB_Production_PFS_50K_RevPit2 - Vista Gold Australia Pty Ltd, 2013

It is understood that in exceptional circumstances water may be temporarily transferred to the either TSF1 or TSF2, to the extent the deposition depression allows, that is to say that water must not pond against the external TSF wall(s), should retention ponds be in danger of overflowing and there is insufficient capacity in the WTP. This option was not included in the GoldSim water balance.

The PWP with a capacity of 185,394 m³ in association with a WTP rate of 600 m³/h is sufficient to receive transfers from RP1, RP2, PRP, TSF1/2, HLP and Batman Pit to prevent uncontrolled overflows from these facilities and the PWP during normal operation. However, the GoldSim model results do show instances of overflows at RP1, RP2 and PRP. This is most likely the result of insufficient pump capacity on pipelines to the PWP during high intensity rainfall events. The water management strategy leading up to and during extreme peak rainfall is likely to invoke different operating rules to those that are represented in the GoldSim water balance which are representative of normal operating conditions. This may involve measures such as the temporary transfer of excess water to the TSFs to the extent the deposition depression allows, that is to say that water must not pond against the external TSF wall(s).

Overflows from the RP1 are less likely during later years of production because the WRD progressively fills the catchment and surface runoff is replaced by less intense seepage flow.

Additional information on stormwater management is located in Appendix N Erosion and Sediment Control Management Plan of the MMP.

2.7 Diversion Drains

2.7.1 Current diversion drains

Four diversion drains currently exist at the site as shown in **Figure 2-3**. Three reduce the volumes of clean surface water runoff entering on-site catchments and one prevents AMD from directly flowing into natural waterways. Details of the diversion drains are as follows:

- Western WRD diversion drain – Constructed during previous operations. It is situated to the west of the WRD and RP1. The drain channels clean surface water runoff from the upper reaches of Burrell Creek away from the WRD and RP1 into West Creek.
- RP1 diversion drain – Commissioned and constructed in late 2011 by the NT DPIR. Situated to the west of the RP1 the drain collects clean surface water runoff from the area between the Western WRD diversion drain and RP1, diverting this clean water away from RP1 and into West Creek.
- LGO stockpile diversion drain – Constructed during previous operations. It is situated adjacent to the eastern side of the LGO Stockpile. The drain captures runoff from the stockpile and channels it into RP2.
- Northwest TSF1 diversion drain – Commissioned and constructed in 2011 by the NT DPIR. The drain captures clean surface water runoff from the western catchment as well as any overflow from Golf and Tollis pits and diverts this water to Horseshoe Creek away from TSF1.

2.7.2 Diversion channel design

The Stormwater Management Plan contains designs for additional channels to divert water around mining facilities. These channels have been designed to convey a 10-year event for around the mining facilities. More information is provided in the Stormwater Management Plan.

Western WRD diversion channel: The expanded WRD is expected to cover much of the existing Burrell Creek. To avoid unnecessary water contact with PAG material, a new channel was designed to catch the water draining off the hill to west and the clean water running off the western half of the WRD.

TSF1 diversion channel: TSF1 will have one diversion channel along the eastern side intercepting clean runoff, diverting it away from the TSF. This channel is proposed to terminate at Horseshoe Creek.

Eastern TSF2 diversion channel: TSF2 will have two channels one of which originates on the northeast side of TSF2 and will flow south until it terminates at Stow Creek.

Western TSF2 diversion channel: The second diversion channel for TSF2 will run from the north side of TFS2 west to Horseshoe Creek and originates directly downstream of the raw water saddle dam spillway. The channel runs west near north base of the TSF2 crossing the TSF2 access road before terminating at Horseshoe Creek.

Batman Creek diversion channel: Batman Creek passes the north and east edge of Batman Pit near the proposed low-grade ore stockpile (LGOS), then flows by the processing plant before draining south to the Edith River. Due to its proximity to both critical facilities (the Pit and Processing Plant) as well as near a landform with PAG material (the LGOS), Tetra Tech designed a channel to transport the runoff around the Pit and past the LGOS and processing plant. The channel was not designed to go all the way around the pit since, according to the EIS, a berm was constructed on the north crest of the pit to stop large event flows from entering the pit from Batman Creek.

2.7.3 Proposed future creek diversions for TFS2

The construction of TSF2 will require the diversion of Horseshoe Creek and Stow Creek. Horseshoe Creek is located on the western side of TSF2 and a section of the creek will be covered by the facility. New diversion channels and levees along Horseshoe Creek and Stow Creek have been designed to protect the embankment of TSF 2 from flooding and erosion. Diversion channels have been designed for the 100-year ARI flood events detailed in **Section 2.8.3**. Both the proposed diversions have been designed to preserve natural conditions with similar stream characteristics to sections of the Stow Creek upstream channel configurations. Additional information on flow characteristics are shown below and further information can be found in Section 4 of the MMP and Appendix A14 of the MMP.

- Stow Creek is located on the south-eastern side of TSF2 and a section of the creek will be covered by the facility. It is proposed that a section of Stow Creek will be diverted away from the toe of TSF2. The Stow Creek diversion designed for a peak flow of approximately 656 m³/s. The channel will be lined with rip-rap to reduce potential scour and erosion. The channel will have a width and length of approximately 60 m and 850 m, respectively, and a nominal depth of 4.2 m.

- It is proposed that a section of Horseshoe Creek will be diverted away from the toe of TSF2. The Horseshoe Creek diversion has been designed to accommodate a peak flow of approximately 182 m³/s comprising 100 m³/s of runoff from the Horseshoe Creek catchment and 82 m³/s of overflow from the existing raw water supply dam. The channel will be lined with rip-rap to reduce scour and erosion and have a width and length of approximately 40 m and 550 m, respectively, and a nominal depth of 2.5 m.

2.8 Surface Water Management Infrastructure and Features

A network of pipelines, pumps, valves and flow meters exist on-site for the purpose of transferring water between the various retention ponds and to and from the Water Treatment Plant (WTP) as part of the site wide Surface Water Management during operations. **Figure 2-4** is a schematic of water use at the site during operations. Detailed below is the WTP and the various parts of the water transfer infrastructure that will be implemented during operations.

2.8.1 Water treatment plant

The water treatment plant (WTP) is a key component of the water management at the MTPA. The WTP will treat excess water collected from several areas of the mine site so that water can be used to satisfy process make-up water demand and manage dust suppression on-site. Treated water will also be discharge off-site if treated water is in excess of site requirements.

The WTP was designed to meet influent water quality and volumes derived via modelling. The water balance model indicates that, over the life of the mine, the capacity of the WTP will need to be 600 m³/hr. The selected treatment process begins with the addition of lime to raise the pH of the influent water to pH 11 to precipitate dissolved constituents, including magnesium, copper, nickel and zinc. Ferric chloride will also be added to promote coagulation and assist in the co-precipitation and adsorption of other metal species, specifically cadmium.

To reduce the footprint of the treatment process, solids are recycled to promote the precipitation reactions. Sulfuric acid will be used to reduce the pH back to neutral, which will facilitate the precipitation of aluminium. Solids collected in the clarifiers will be disposed of to the TSF, and water used to backwash the microfilters will be recycled through the WTP. **Figure 2-6** shows the treatment process and **Figure 2-7** shows the general arrangement of the WTP.

The WTP has an automated control system, connected to the site telemetry network to allow the remote viewing and control on the system, which monitors the pH levels in the reaction tank to regulate the slaked lime quantity delivered.

Treated Water Quality

The water treatment process has been designed to treat water to an effluent quality so that, with appropriate management, it can be discharged to the Edith River via Batman and Stow Creeks. **Table 2-5** shows the expected effluent quality from the WTP. The treated water discharged from the TWHT will be managed based on the data received from the real time telemetry at SW4 on the level of the Edith River (**Section 2.8.8**) to ensure that the correct dilution is achieved to meet the water quality requirements in the current WDL.

Table 2-5 Expected WTP Effluent Quality (MMP Appendix A13)

Analyte	Unit	C _{SW2}	TV	C _{WTP}	Effluent Goal
Magnesium	mg/L	1	2.5	31	25
Sulfate	mg/L	1	129	2,561	Refer to Section 3.1
Aluminum	µg/L	764	55	55	44
Cadmium	µg/L	0.1	0.2	2.1	1.7
Cobalt	µg/L	1	13	241	193
Chromium	µg/L	1	1.0	1.0	0.8
Copper	µg/L	2	1.4	1.4	1.1
Manganese	mg/L	0.025	1.9	37.5	30.0
Nickel	µg/L	0.9	11	203	162
Lead	µg/L	1	3.4	49	39
Iron	mg/L	1.4	0.3	0.3	0.24
Mercury	µg/L	0.05	0.6	11	8.8
Zinc	µg/L	7.95	8	8.9	8.0

However, the GoldSim water balance model shows that the simulated average output from the WTP is 4.4 GL/yr over the LOM and assumes transfers from RP1, RP2 and Batman Pit occur whenever there is spare storage in the PWP. The model shows that no water will be discharged from the WTP to the Edith River as the fixed process plant water demand wholly consumes the WTP treated water. However, if the process plant shuts down and no changes to WTP inflows occur, WTP treated water will be discharged to the Edith River. Discharge of treated water is expected to only occur in high rainfall conditions.

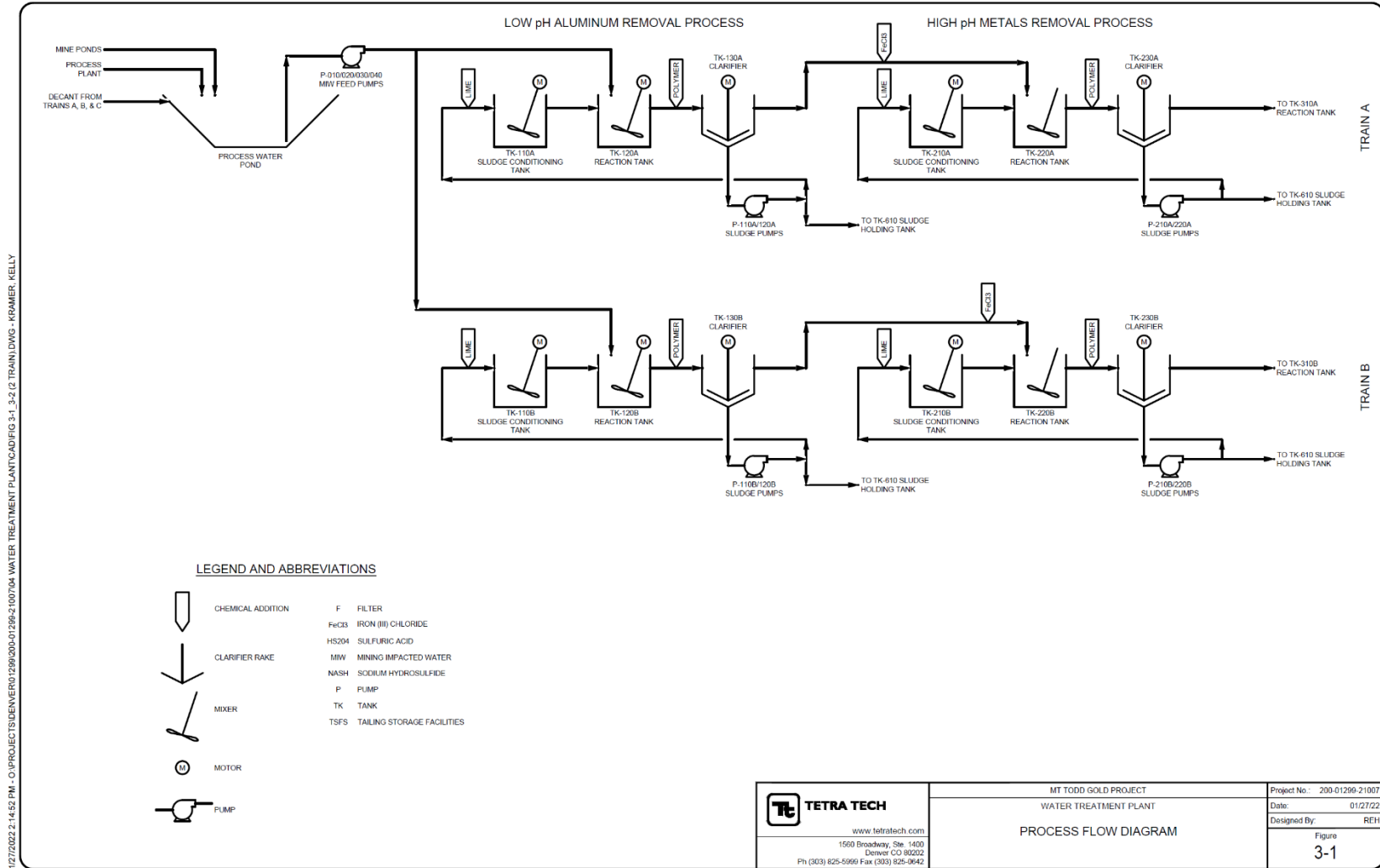

Figure 2-6 WTP Process 1 of 2

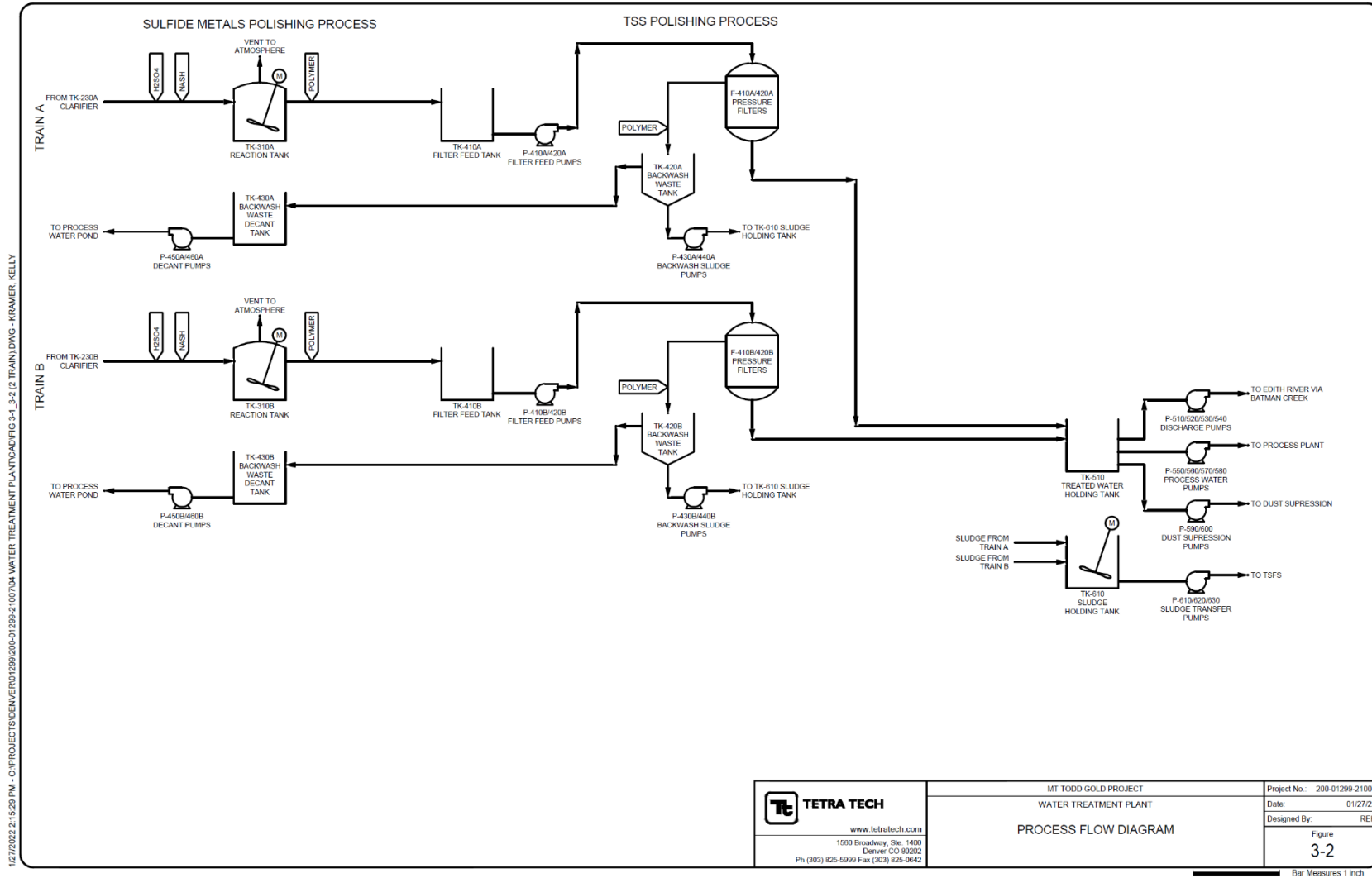

Figure 2-7 WTP Process 2 of 2

Overflows to the Environment

The GoldSim model simulations have assumed a WTP with a capacity of 500 m³/h, in association with a PWP capacity of 185,394 m³ and a combined pump capacity for transfers from retention ponds (including TSF) to the PWP of 46,800m³/day.

The maximum rate of inflow to the PWP is constant (13,584 m³/day) during production and is controlled by a combination of PWP capacity and its net rate of evaporation together with available treatment capacity.

The GoldSim model shows that the PWP and WTP are able to prevent overflows of untreated water from retention ponds during normal operating conditions. However, the results also show that overflow from RP1, RP2, HLP and RP5 (This will change to PWP and the GoldSim Model will need revising with new volumes and flows) can occur during high intensity storms and is possibly the result of insufficient pump capacity on pipelines to the PWP.

The water management strategy leading up to and during extreme peak rainfall will involve measures such as the temporary transfer of excess water to the TSFs to address the risk of overtopping. Any temporary transfer of excess water to the TSFs will be conducted in accordance with the operating guidelines set out in the TSF Operators Manual (as developed during the detailed design prior to construction). Transfer of water will be conducted so that no water will have the potential to be in close proximity to constructed TSF walls. Also, given the possibility of the occurrence of overflows during periods of extreme rainfall it is likely that flows within the Edith River will also be higher than normal and the dilution criteria for discharge to maintain compliance for water quality in the Edith River should not be breached.

Emergency measures, including the temporary transfer of water to the Raw Water Dam, will be considered in circumstances where significant and imminent safety or environmental risks exist. The additional emergency measures would consider the structural stability of the site's water holding structures and the water quality of the source and destination water. The Raw Water Dam is a key structure that will be considered due it's significant capacity.

2.8.2 Cross drainage structures and haul roads

Flood modelling shows that existing cross drainage structures on Batman Creek and Horseshoe Creek will be overtopped during the 10-year and 100-year ARI flood events, also a significant length of the road adjacent to the TSF1 will be inundated. The model results also show that these culverts cause backwater effects upstream but this does not appear to cause inundation of mine infrastructure (**Figure 2-8**). Furthermore, this backwater effect only occurs during extreme flood events and is therefore unlikely to be a frequent occurrence.

Overtopping of cross drainage structures and haul roads is likely to be an infrequent occurrence but upgrades to existing stormwater drainage, erosion and sediment controls, including the vegetation of verges, will be implemented to minimise damage during less extreme but more frequent storm events. Similar protection measures will be required for new roads with suitable cross drainage structures to convey drainage beneath roads to prevent scour.

2.8.3 Channel protection

An indication of the erosion potential of 100-year ARI flood flows has been obtained from the velocity results of hydraulic flood routing. This shows a number of locations along creeks may experience flow velocities of greater than 2m/s (**Figure 2-8**).

Whilst the majority of these locations are sufficiently distant from mine infrastructure to be of no immediate risk, the section of Batman Creek adjacent to the processing plant is likely to experience high velocity flows during extreme flood events. Rip-rap protection to earthwork embankments adjacent to the existing drainage channel on the east side of the proposed process plant will be installed for channel protection.

Sections of Stow Creek in the vicinity of the proposed embankment of TSF2 are also expected to experience high flow velocity during extreme flood events. Scour protection measures will include the placement of rip-rap along the proposed channel diversion works (Appendix A14 – Stormwater Management Plan).

All TSF designs will incorporate considerations of safety and environmental factors. Structural stability will be considered first and foremost, while operational functionality, logistical, and environmental factors will be incorporated into the TSF design, construction and operation. This includes the potential change to hydrological processes upstream and downstream of the proposed TSF.

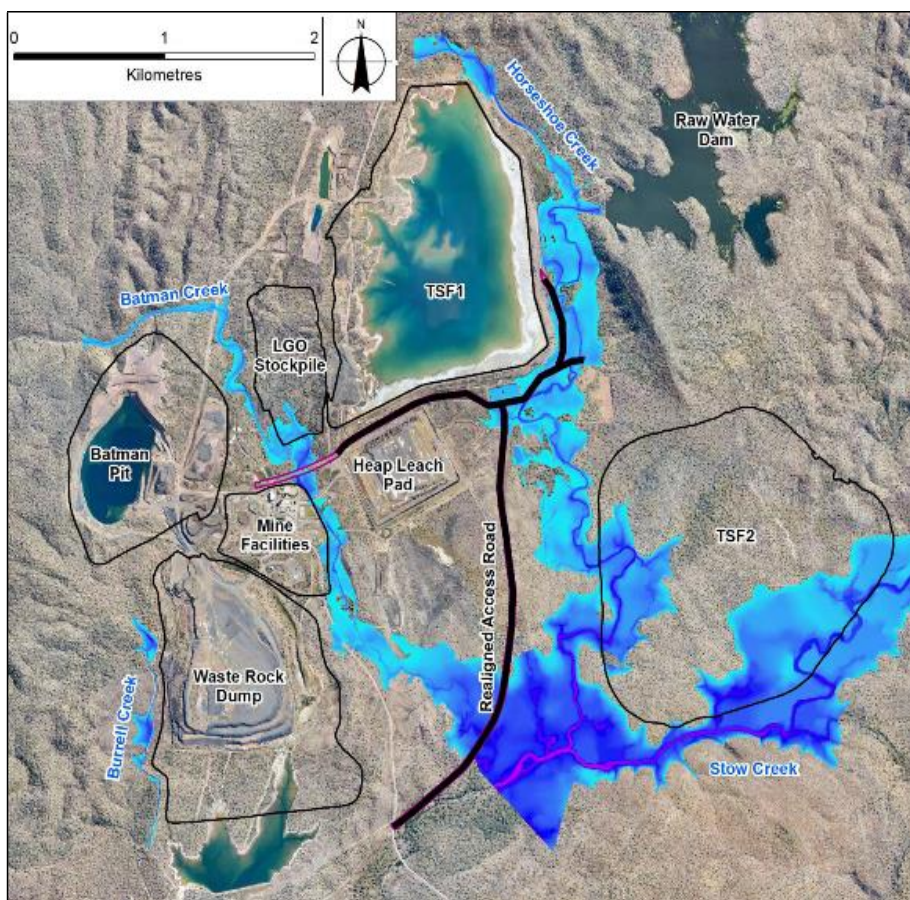

Figure 2-8 Modelled 100-year ARI Flood Extent

2.8.4 Prevention of surface water contamination

The potential for contamination of receiving waters has been reduced by segregation of “clean” stormwater runoff from “dirty” stormwater runoff and the collection and treatment of “dirty” stormwater runoff from areas within the mine site.

“Dirty” stormwater runoff emanates from disturbed mining areas including mine pits (pit water) and material storage dumps. “Clean” stormwater runoff results from rainfall on undisturbed areas.

The method by which surface water contamination is to be minimised is provided below for each of the land use areas.

HLP

The heap leach facility was a purpose built and lined basin for the stockpiling of ground oxide ore and treatment for mineral recovery via cyanide irrigation during previous operations. A moat surrounds the leach pad and sits within the lined basin, which receives inflows either as direct runoff from, or as seepage through, the leach heap. The structure contains an estimated 214,000 m³ of various small grain sized material, which undergoes significant erosion during the wet season, leading to siltation of the moat. It is proposed at a later stage (year 7 of operations) to reprocess the HLP material.

The moat has an estimated capacity of 12 ML, which fluctuates from year to year as eroded heap sediments fill the moat, and subsequently excavated from the moat annually to reduce the risk of an overflow during the wet season. The moat has one dewatering pump which is located in the southern moat, pumping water to the PWP. The HLP moat does not receive any inflows external to the lined facility. All inflows are restricted to direct incidental rainfall or HLP runoff.

The structure has no engineered spillway, if the moat was to exceed capacity it would commence spilling approximately midway along the southern wall. The water level in the moat is managed to minimise the risk of an uncontrolled spill and water is pumped to the PWP. The moat has three pump locations along the southern wall and currently only one pump is required to maintain HLP moat levels adequately.

To minimise erosion, pipes and windrows atop the HLP capture and transfer water to the moat. The water quality within the moat is poor but comparatively better than other retention ponds on-site. A small surface seep is evident on the north-eastern corner of the HLP when the moat is full. The complete integrity of the lining is unknown but likely compromised as evidenced by weathering in patches and poorer quality of chemical results from the adjacent groundwater monitoring bores.

The moat will be relined with 1mm HDPE during the first two years of operations.

The HLP material will be processed once the pit ore is exhausted and the existing liner and associated materials will be disposed of in a TSF. This will eliminate it as a permanent point source for potential contamination.

Mine pit water

Mine pit water will evaporate or be pumped to the WTP where it will re-used in mining operations. The amount of water in the pit is reduced by minimising the stormwater runoff into the pit by construction of runoff barriers (e.g. engineered mounds/levees) around the mine pit.

Material storage dump areas

WRD construction will include 8 m wide benches at 30 m vertical intervals on the face of the WRD and each lift will be constructed at 34°. These benches will function as stormwater drainages and as access for closure cover installation, reclamation activities and maintenance. In general stormwater runoff from material storage dumps has been minimised or will be minimised by:

- Constructing dumps in a manner that dissipates runoff through seepage and evaporation
- Constructing the outer batter slopes of dumps with inert overburden material
- Construction of perimeter drains that collect runoff from the outer batter slopes and perimeter areas
- Construction of drainage lines that convey runoff from dump perimeter drains to water retention ponds
- Construction of water retention ponds that are sized to capture an ARI wet season rainfall appropriate to their hazard category plus an appropriate freeboard allowance for sedimentation

Processing plant areas

Surface water runoff from the processing plant area may contain traces of heavy metals, dust and soil particles that can reduce surface water quality if allowed into natural watercourses. The plant area will be surrounded by a bund forming a controlled drainage area.

Undisturbed Areas

Runoff from undisturbed land within and upstream of the mine site will be kept separate from “dirty” runoff from undisturbed areas within the mine site. “Clean” runoff will be diverted downstream of the mine site with no further treatment.

Extreme Rainfall Event Management

During extreme rainfall events in excess of the water management system design, the following procedures are proposed:

- Regular comparison of storage levels with prescribed Mandatory Reporting Levels will provide advance warning of potential containment issues and the early implementation of measures to help maintain storage levels within design guidelines during higher than normal rainfall periods
- If all water storages are at or near capacity, excess water will be redirected to the TSF up to the height of beached tailings for temporary storage
- Additional stand-by pumps will be used to increase the transfer capacity between affected ponds and the TSF or pit
- Water retention ponds have been designed to overflow and discharge to the natural environment.

2.8.5 Pipelines and Pumps

Currently the site is equipped with High-Density Polyethylene (HDPE) pipelines of various diameters that are used to transfer surface waters in efforts to minimise uncontrolled discharges from retention ponds. Variation in pipe diameters evident on many pipelines has resulted from the reuse and recycling of piping inherited when site management commenced. Prior to operations commencing, the length and size of pipes will be optimised to obtain the best efficiency for the site and minimise power consumption. Currently, a number of pumps are utilised on-site to transfer water between retention ponds and the WTP and, previously, to discharge treated water offsite.

All of the current pumps are in good working condition and capable of coping with the average wet season demands of the site during non-exceptional rainfall conditions. An automated start/stop system has been installed which enables the remote control of most pumps from the site office via telemetry. Some manual control of the pumping systems will always be necessary as a number of the pumps fail to maintain their prime and require checking prior to starting in order to protect the equipment.

Table 2-6 Preliminary Pipe and Pump Requirements for Operations

Source			Pipe					Discharge					
No.	Name	Code	TWL	BWL	Pump Size	Length of Pipe	Size of Pipe	Flowrate	Name	Code	TWL	BWL	
			(mAHD)	(mAHD)	(kW)	(m)	(DN)	(m ³ /hr)			(mAHD)	(mAHD)	
1	Waste Rock Dump	RP1	121	112	101 kW	2,600 m	DN 375	600 m ³ /hr	Process	Water Pond	PWP	128	0
2	Low Grade Ore Stockpile	LGOS	119	114	40.0 kW	1,300 m	DN 315	450 m ³ /hr	Process	Water Pond	PWP	128	0
3	Tailings Storage Facility 1	TSF1	135	130	22.0 kW	600 m	DN 300	250 m ³ /hr	Process	Water Pond	PWP	128	0
4	Heap Leach Pond	HLP	134	134	6.3 kW	1,000 m	DN 250	194 m ³ /hr	Process	Water Pond	PWP	128	0
5	Batman Pit	RP3	138	14	375.0 kW	1,250 m	DN 375	750 m ³ /hr	Process	Water Pond	PWP	128	0
6	Tailings Storage Facility 2	TSF2	170	120	22.0 kW	600 m	DN 300	250 m ³ /hr	Process	Water Pond	PWP	128	0
7	Process Plant	PP	132	0	1,500 kW	3,700 m	DN 700	2,547 m ³ /hr	Tailing Storage Facility 1 & 2		TSF1 & TSF2	170	0
8	Process Retention Pond	PRP	126	0	27.0 kW	1,600 m	DN 200	70 m ³ /hr	Process	Water Pond	PWP	128	0
9	Process Water Pond	PWP	128	0	27 kW	75 m	DN 450	600 m ³ /hr	Water Treatment Plant		WTP	129	0
10	Water Treatment Plant	WTP	126	0	27.0 kW	2,330 m	DN 450	600 m ³ /hr	Process	Plant	PP	135	0
11	Raw Water Dam	RWD	137	129	80 kW	3,850 m	DN 450	750 m ³ /hr	Process	Plant	PP	132	0
12	Tailings Storage Facility 1	TSF1	135	130	75.0 kW	1,970 m	DN 600	2270 m ³ /hr	Process	Plant	PP	132	0
13	Tailings Storage Facility 2	TSF2	170	120	185.0 kW	3,060 m	DN 600	2270 m ³ /hr	Process	Plant	PP	132	0

The pumps located at Batman Pit (installed and commissioned in late 2012-early 2013) were used for discharging treated water from Batman Pit to Batman Creek in accordance with the conditions outlined in the (no rescinded) WDL. These pumps are no longer required for operations and have been preserved and retired.

2.8.6 Flow meters

Currently one in-line magnetic flow meter is installed on-site. The in-line magnetic flow meter is located at:

- RP1 primary 500 mm siphon to measure discharge from RP1.

An additional flow meter will be required at the outflow of the TWHT to measure the volume discharged to the environment. Flow meters will also be installed on pumping infrastructure to determine the water balance on-site and information modelled in GoldSim.

2.8.7 In-situ data loggers

Vista Gold have installed in-line data loggers to continuously analyse pH, conductivity and temperature at SW4 to manage the water quality at SW4. An in-line data logger will be installed to monitor the water quality of the treated water discharged from the WTP TWHT. This system will provide an early warning if water quality entering the Edith River has the potential to exceed water quality requirements. The loggers will be maintained on a routine basis and routine calibration of the probes will be conducted.

2.8.8 Gauging stations

Three stream gauging stations currently exist at the MTPA. The Horseshoe Creek and Stow Creek (SW3) stations commissioned by the DME in 2008 as part of environmental assessment activities, and a gauging station at SW4 was installed by Vista Gold in late 2012. All three sites collect continuous stream water level, and water quality parameters of EC, pH and temperature. A rainfall gauge also currently exists at the Horseshoe Creek station and flow is calculated through an empirically derived rating table.

Other continuous monitoring systems at the MTPA are the water level monitoring station at RP1 (late 2012 installation) and the site weather station (mid 2011 installation). The site weather station is located atop the ridge to the west of the TSF1 scats dump, this selected location is the most; stable long-term position, representative of the site and unlikely to be affected by mining activity.

All continuous monitoring stations connect to the site telemetry to provide real time information at the site office and over the company intranet. The real time levels at SW4 will also automatically determine the discharge rate from the WTP TWHT.

2.9 On Site Water Use

Water demands comprise mainly of the requirements for:

Processing Plant 30,564 m³/day (11.2 GL/yr)

- Average supply from WTP: 4.0 GL/yr
- Average supply from TSF: 5.6 GL/yr

- Average supply from RWD: 1.6 GL/yr

The GoldSim simulation results confirm that processing plant water demands can be supplied without failure by a combination of supply from the WTP, RWD (assuming an infinite resource) and reclaim water from the TSF. The WTP contributes a constant daily flow of 14,400 m³/day. Shortfalls in the processing plant demand are made up by transfers from the RWD and/or TSF at maximum rates of 18,000m³/day and 27,456 m³/day, respectively.

Dust suppression requires an average daily demand of 560 m³/day where the monthly demand has a maximum of 1,153 m³/day in July/August and a minimum of 220 m³/day between November and March.

- Supply from RWD: 0.8 GL/yr

Water supply for dust suppression is obtained from the WTP and RWD. Transfers will be made to a storage tank with a capacity equivalent to two days maximum dust suppression (2 days x 1,153 m³/day x 0.95 = 2,191 m³). The GoldSim model shows that the majority of water requirements are sourced from the RWD

3 Groundwater

Groundwater flow direction of north to south towards the Edith River remains constant throughout the year. Groundwater discharge to the Edith River and its tributaries is expected, since groundwater elevations are higher than the adjacent creek and riverbed elevations. The expected regional groundwater flow direction from the Arnhem Escarpment in the east to the Daly River in the west was not observed at the mine site. However, a regional east to west flow direction is believed to be present based on the topography and the fact that the Edith River (which appears to act as a groundwater discharge point) flows from east to west.

A groundwater aquifer in the traditional sense does not exist at the MTPA. The coarse gravel media present generally averages between 1.5 and 5 meters in depth. This shallow surface layer and tight bedrock geology produces a very limited groundwater system that is observed by the rapid increase and decrease in the volume of water before and after precipitation in the Edith River. In addition, the fact that the Edith river frequently ceases to flow in the dry season further bears out the fact that a traditional groundwater system is not present at the MTPA. The lack of flow exhibited by the Edith River during the dry season is due to the Katherine limestone that makes up the escarpment to the north and east.

3.1 Groundwater Model Results Mining-phase (Tetra Tech 2019)

Tetra Tech revised the 2013 Hydrogeology report for the MTPA in April 2017 and again in October 2019. The modelling results show that potential impacts related to the proposed mining-phase activities include changes in groundwater levels, groundwater flow directions, and stream flows as a result of pit dewatering and on-site water management. Prediction of groundwater inflow to the pit is a component of impacts prediction that is important to mine planning and management of discharges from pit dewatering. The quality of any discharged groundwater is also of potential significance.

Groundwater chemistry data to date indicate that leakage from some of the existing surface water impoundments at the mine site has resulted in minor localised groundwater contamination. New water-retaining structures such as the proposed TSF2 have been designed to limit leakage to the underlying groundwater system. Current groundwater data does not indicate that any groundwater bores are discharging contaminated groundwater to the surface.

Groundwater chemistry data have indicated that 'background' or 'boundary' bores have elevated metals (and metalloids) typical of mineralised areas and that local groundwater is not suitable as a potable supply without further treatment.

Drawdown of the local aquifer associated with the proposed development is not likely to have a significant impact on the local groundwater flows into the Edith River or to neighbouring groundwater supply bores at Werenbun and Leliyn (Edith Falls).

The proposed Batman Pit deepening and enlargement are likely to result in a terminal sink pit lake with a water level significantly below the surrounding land surface. The steady state pit lake water level elevation is predicted to be approximately -15 mAHD. This is expected to prevent outward migration of pit lake water into and through the aquifer. Evaporation from the pit lake may cause the dissolved constituents in the water to concentrate over time, with the possibility of forming a brine.

3.1.1 Predicted groundwater inflows to Batman Pit

Estimated groundwater inflows to the Batman Pit during mining are shown graphically in **Figure 3-1**. Predicted groundwater inflows ranged from a few litres per second at the start of mining to approximately 2 L/s during the final months of mining. Short-term variability of inflows calculated by the model has been smoothed by plotting the inflows as cumulative average values. Although the proposed mining would deepen and laterally expand the pit gradually, the model simulated pit deepening and lateral expansion in a step-wise fashion.

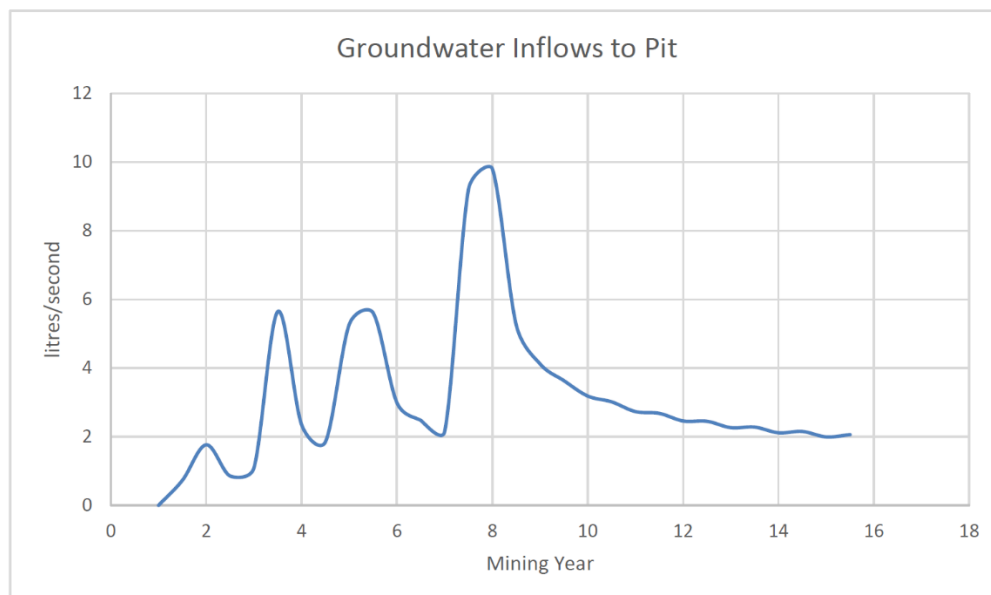
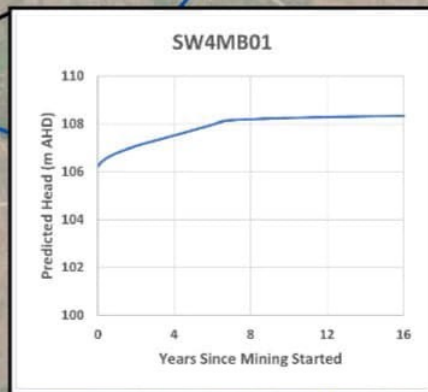
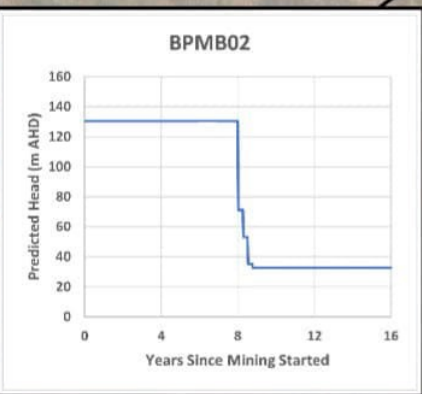
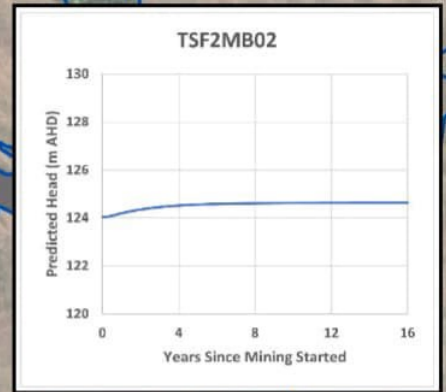
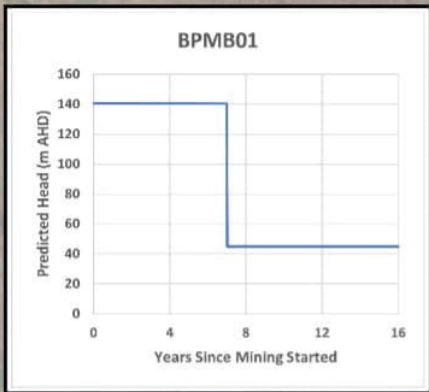
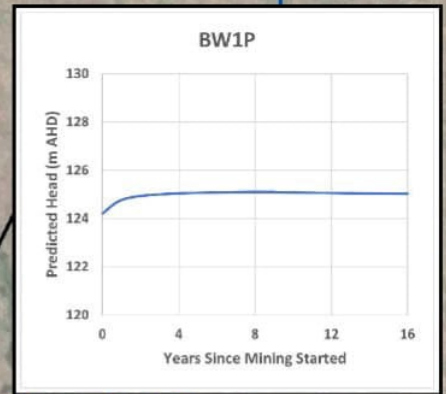

Figure 3-1 Predicted groundwater inflows to Batman Pit

3.1.2 Predicted groundwater level changes

The mining-phase simulation also provided estimates of predicted drawdown related to mine dewatering operations. The drawdown was calculated by subtracting the water table elevation at the end of mining from the steady-state water table elevation. The maximum predicted drawdown at the end of mining was approximately 595 m, the depth of the pit below the initial steady-state water table. Drawdown was predicted to decrease rapidly with distance from the pit, with the 10 m drawdown contour extending only to about the rim of the pit and the 1 m drawdown contour extending less than 450 m from the rim of the pit.

Modelled changes in water levels at the locations of several monitoring bores are illustrated on **Figure 3-2**. Very little water level change was predicted for locations except BPMB01 and BPMB02 near the Batman Pit, where rapid and large declines were predicted when the expanding pit approaches the bore locations. Water levels at bores BW1P, BW17P, TSF2MB02, WDMB02, and SW4MB02 adjacent to the Edith River near the downstream side of the Project area was predicted to rise slightly, or WDMB02P near the WRD retention pond. The water level at location BW1P east of Batman Pit and south of TSF1 was predicted to rise while TSF1 is active during the first five years of mining and then decline to about 1.5 m below its initial level by the end of the mining period, after TSF1 has drained for about nine years. Water levels at BPMB01 and BPMB02 near the Batman Pit were predicted to decline in response to pit dewatering during the mining phase.



Legend

- Selected Water Bodies
- Bore Locations
- Proposed Batman Pit Extent

SCALE IN METRES
0 500 1,000

1 centimetre = 500 metres
GDA 1994 MGA ZONE 53



NOTES:
This figure contains imagery (shaded relief) from ESRI imagery web mapping service, provider of worldwide basemap, aerial, and satellite imagery. Go to www.esri.com for further information.

TITLE:
PREDICTED HEAD CHANGES AT OBSERVATION LOCATIONS



ISSUED FOR:
 VISTA GOLD

ISSUED BY:
 TETRA TECH
350 Indiana Street, Suite 500
Golden, Colorado 80401
(303) 217-5700 (303) 217-5705 fax

PROJECT: MT. TODD GROUNDWATER MODEL
LOCATION: NORTHERN TERRITORY, AUSTRALIA
PROJECT NO.: 117-8348002
DATE: 01/2022

Figure 3-2

3.1.3 Predicted stream flow changes

Stream flows were monitored along the Edith River near the confluence with Stow Creek (Edith River SW4) and near the downstream side of the mine area (Edith River SW10) and along the lower reaches of Stow Creek (Stow Creek SW3). Stream flows at all three locations were predicted to increase slightly during the first five years of mining, as the head in TSF1 increased and seepage from TSF1 into the alluvium along Horseshoe Creek likely increased, and then decreased with the decline in heads at TSF1 following its closure (**Figure 3-3**). The predicted stream flows at the end of the mining period were reduced from the modelled stream flows at the start of the mining period by 0.1 percent at both locations along the Edith River and by 0.78 percent along Stow Creek.

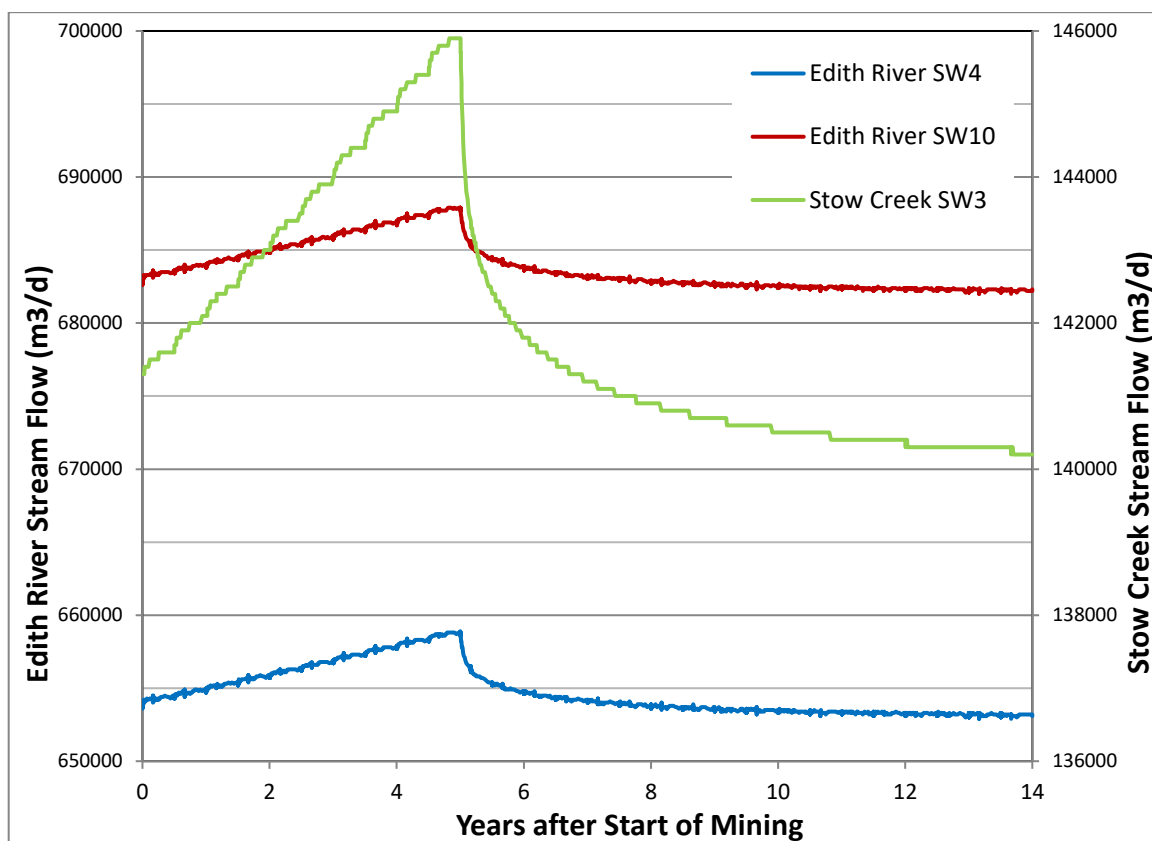

Figure 3-3 Predicted stream flows during mining phase

3.2 Groundwater Demand

Groundwater will be extracted as part of the pit dewatering. External pit dewatering using dewatering bores is unlikely to be viable or necessary due to the relatively low flow rates generally observed in the hornfelsed BCTF. In-pit groundwater extraction is expected to be performed using sumps. The groundwater removed from the proposed pit is likely to be acidic and contain elevated concentrations of metals or other contaminants and therefore should be assumed to be unfit for raw or potable water supply without additional treatment. This water will be pumped to the PWP for use in the process plant or treated in the WTP.

The demand for groundwater for potable and raw water use is unlikely, as drinking water will be sourced from the RWD. Although BW6P is currently in use as a raw water supply, this water and the water from other existing pumping bores is considered too elevated in metal

concentrations for use as potable water without treatment. The bores considered background for this site have elevated concentrations of some analytes.

3.3 Groundwater Management Infrastructure/Features

3.3.1 Groundwater bores and monitoring piezometers

A number of groundwater bores were installed in the early 1990s during the early stages of the initial MTPA development with an aim to develop a reliable water supply for milling operations. The BW prefix named bores focussed on the exploration and testing of groundwater as a resource for the mine in the Burrell Creek Formation and a number were subsequently fitted with pumps. However, the aquifers of the local area are primarily of the fractured rock type, and as a result only low flow rates from individual bores were achieved. At one stage of the project, a number of groundwater bores were connected onto a ring main in efforts to bolster supply quantity and consistency.

A number of monitoring bores/piezometers were installed during operations, primarily nearby to surface water structures to facilitate monitoring programs. Construction and documentation standards of adequate head works, casing packing or machine slotted screens for the majority of these monitoring bores are generally poor with most being absent, as evidenced by on-site camera inspections.

Since operations ceased the majority of any groundwater-pumping infrastructure has been either removed or abandoned and in the case of pipelines, claimed by fire. Little or no maintenance has been conducted to the existing groundwater bores since operations concluded. A number of bores still contain old pumps that have become silted in place, have damaged casings from fire, exhibit artesian flow or permit surface waters to enter the groundwater directly due to an absence of adequate standpipe height or capping. This limits the number of bores available for monitoring.

A number of monitoring bores were installed by GHD (2012). These bores were installed for the following groundwater elevation monitoring purposes:

- BPMB01 and BPMB02 – Monitoring of the current and proposed Batman Pit highwall water levels and interaction with the proposed waste dump.
- WDMB02 and WDMB02 – Monitoring of the RP1 and waste rock dump area.
- TSF2MB01 and TSF2MB02 – Monitoring of the interactions between the proposed TSF2 location and the nearby surface water features (raw water supply reservoir and Stow Creek).
- SW4MB01 – Monitoring groundwater adjacent to the Edith River.

These bores were installed in locations outside the footprints of nearby existing and proposed infrastructure. The primary purpose was to monitor groundwater elevations, not water chemistry. Of the bores shown in **Figure 3-3**, BPMB01, BPMB02, TSF2MB01, TSF2MB02, SW4MB01, BW29, BW17, BW18, and BW6 can all be considered boundary bores. However, as the Project develops, additional monitoring bores may be necessary, and the boundary bores may serve other purposes.

A small amount (approximately 3 ML) of groundwater is extracted from BW6P bore using existing pumping infrastructure for use in care and maintenance activities. Working pumping infrastructure is also present at BW10P but not actively used.

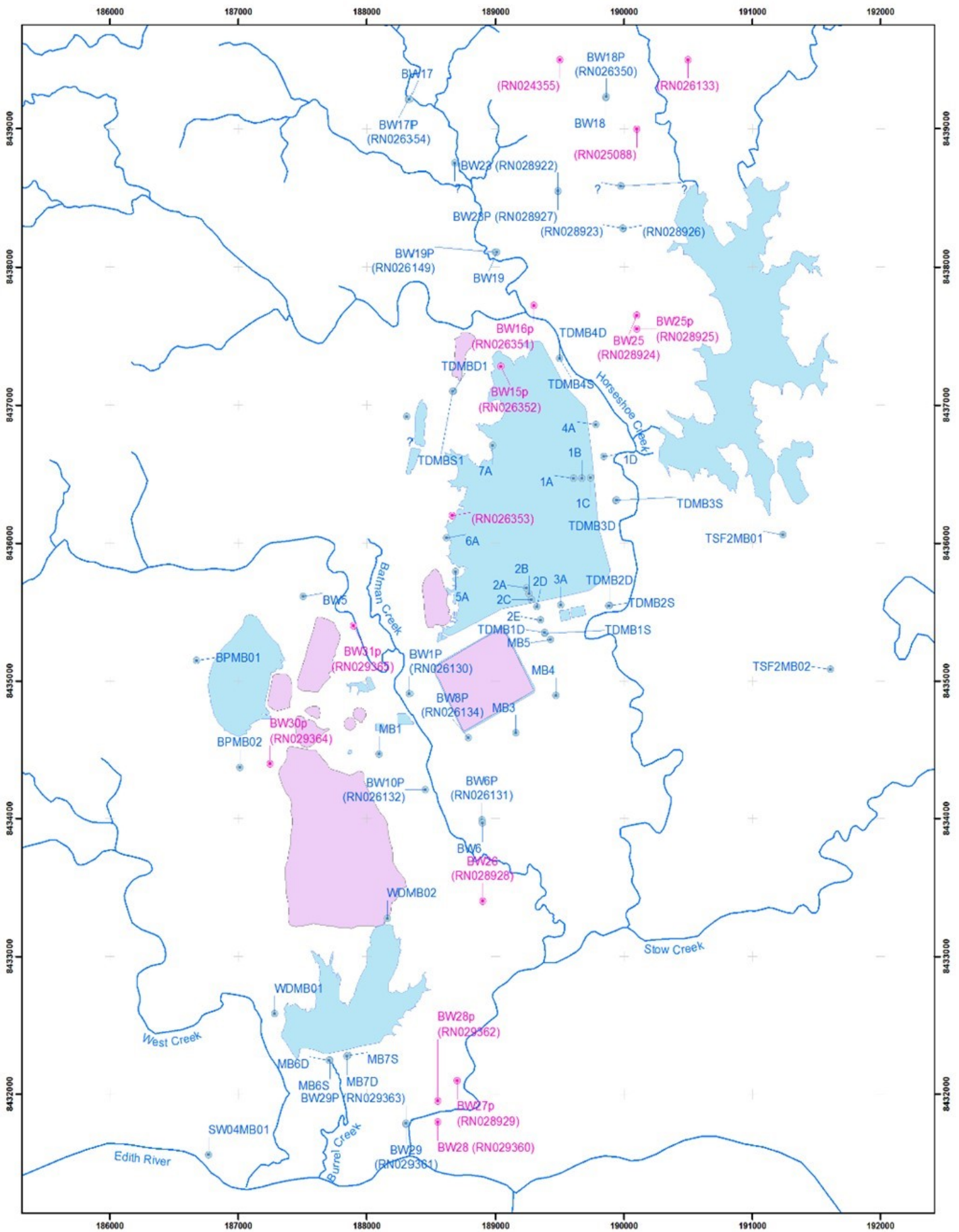

Legend

 Retention Ponds	 GW Bores Located	 No
 Creeks & Rivers		 Yes
 Stockpiles		

Figure 3-4 Bore Location Map

Map Projection: Universal Transverse Mercator
 Horizontal Datum: Geocentric Datum of Australia
 Grid: Map Grid of Australia 1994, Zone 53
 Revision:0 Date:6/4/203 Map By: A Brandis

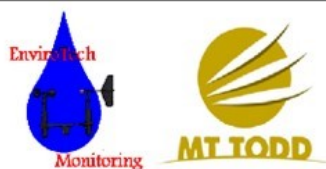
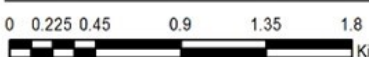

Groundwater Bores across ML

Vista Gold Australia Pty Ltd
 Mt Todd Gold Project

Envirotech Monitoring makes every effort to ensure this map is free of errors but does not warrant the map or its features as either spatially or temporally accurate beyond its intended general reference use. This map is provided without any warranty of any kind whatsoever, either express or implied.

3.3.2 Additional groundwater management infrastructure

To Vista Gold's knowledge, no bores or other infrastructure were used for groundwater injection or groundwater contaminant recovery. No other specifically engineered structures, other than the TSF underdrainage system or lined retention ponds, have been identified on the site for the purposes of seepage limitation, interception and mitigation. **Table 3-1** lists the bores located on all the Vista Gold's exploration and mine leases, however, not all bores have been located or used for monitoring as shown in **Figure 3-4** which show bores that were not located (shown in pink).

Table 3-1 Groundwater Bores

Physically Located	Bore Number as marked on casing	RN Number	Northing	Easting	Elevation
Yes	MB4		189468.862	8434893.873	129.57
Yes	MB3		189158	8434624	
Yes	MB5		189426.53	8435302.35	
Yes	TDMB1S		189383.157	8435346.942	124.77
Yes	TDMB1D		189381.372	8435351.568	124.56
Yes	TDMB2D		189887.907	8435549.062	123.87
Yes	TDMB2S		189882.008	8435544.065	124.07
Yes	MB1		188099.519	8434470.273	131.06
Yes	BW1P	RN026130	188331.699	8434907.204	127.56
Yes	MB6S		187714.2	8432246.7	
Yes	MB7S		187855.29	8432280.52	113.48
Yes	BW29	RN029361	188306.79	8431781.467	112.8
Yes	BW29P	RN029363	188306.845	8431788.955	112.9
Yes	BW5		187506.717	8435612.504	142.88
Yes	TDMBD1		188670.07	8437099.535	143.16
Yes	TDMBS1		188665.099	8437099.165	143.21
Yes	TDMB4D		189497.626	8437339.708	132.44
Yes	TDMB4S		189499.168	8437336.876	132.03
Yes	TDMB3D		189937.183	8436307.725	125.32
Yes	TDMB3S		189941.531	8436310.49	125.24
Yes	BW10P	RN026132	188452.606	8434213.144	123.3
Yes	BW6P	RN026131	188893.019	8433988.369	121.54
Yes	BW19P	RN026149	188997.127	8438108.581	138.45
Yes	BW19		189008.513	8438106.611	138.33
Yes	BW23P	RN028927	189484.649	8438548.43	141.36
Yes	BW23	RN028922	189485.511	8438551.786	141.49
Yes	BW18		189859.603	8439226.397	140.69
Yes	BW18P	RN026350	189861.874	8439232.408	140.64
Yes			189978.976	8438586.333	145.16
Yes			189975.405	8438588.014	145.13
Yes		RN028926	189992.456	8438278.191	145.52
Yes		RN028923	189991.45	8438281.571	145.36
Yes			188680.384	8438755.031	139.35
Yes	BW17P	RN026354	188326.269	8439214.794	141.85
Yes	BW17		188334.493	8439215.977	142.33
Yes	BW8P	RN026134	188788	8434591	
Yes	MB7D		187846.51	8432275.37	
Yes	TSF2MB01		191239.441	8436060.05	138.77

Physically Located	Bore Number as marked on casing	RN Number	Northing	Easting	Elevation
Yes	TSF2MB02		191608.559	8435084.255	141.36
Yes	BPMB02		187012.31	8434374.822	145.67
Yes	BPMB01		186675.178	8435148.078	171.64
Yes	WDMB01		187284.957	8432583.777	124.15
Yes	1D		189841.626	8436628.22	165.49
Yes	2D		189320.141	8435537.659	
Yes	2E		189349.77	8435444.039	
Yes	3A		189509.339	8435553.436	
Yes	4A		189780.333	8436857.245	
Yes	MB6D		187709.73	8432246.02	
Yes	WDMB02		188162.236	8433274.432	125.74
Yes	SW04MB01		186767.924	8431559.732	111.64
Yes	BW6		188895.028	8433966.356	121.27
Yes			188314.03	8436915.96	
Yes	5A		188686.581	8435794.5	
Yes	6A		188614.787	8436037.641	
Yes	7A		188978.006	8436707.673	
Yes					
Yes	1A		189607.13	8436467.74	
Yes	1B		189673.262	8436470.282	
Yes	1C		189740.323	8436473.113	
Yes	2A		189241.08	8435674.092	
Yes	2B		189259.607	8435632.574	
Yes	2C		189277.823	8435591.473	

3.4 Management Measures

Potential management measures to limit the groundwater impacts due to the proposed mining project include:

- Any bores that do not meet the minimum construction requirements for water bores in Australia (LWBC, 2003) should be decommissioned or rehabilitated in accordance with the methods in the guidelines
- Lift works on the existing TSF should not be undertaken until all bores in the vicinity are rehabilitated
- Any exploration drill holes that may act as conduits interacting with mine features will be considered for rehabilitation
- Groundwater extracted from the proposed Batman Pit during operation (and other pit water) will, if necessary, be treated to the same level as other site water prior to discharge
- All potential contaminants brought onto site (i.e., fuel, explosives, process reagents, etc.) will be itemised, and plans will be developed for their management;
- TSF2 will be designed, constructed and rehabilitated in a manner that will minimise oxidisation of sulphides and leakage of any liquor or leachate

- TSF1, HLP and associated infrastructure will be rehabilitated to either significantly reduce seepage or improve seepage water quality
- The new waste rock dump will be constructed in a manner such that it will not result in significant changes to the local groundwater regime or the development of AMD (and potentially in such a manner that it limits AMD occurring in the existing waste rock dump)
- Monitoring will be continued to ensure that the groundwater impacts are not greater than those predicted by these works
- Validating, refining, updating and improving the groundwater model will be continued (at least on an annual basis) then used to confirm closure scenario assumptions and be used to aid closure management decisions

This ongoing monitoring will include:

- Monitoring of groundwater levels (and usage) on the ML and at nearby government bores where data is publicly available (G8140152 and G8140022 at Edith Falls and Edith River). A series of trigger values to monitor and manage any drawdown or contamination impact resulting from the proposed development will subsequently be developed
- Geochemical monitoring of key groundwater bores (including those deemed 'background' or 'boundary' bores) will be continued on a bi-annual basis
- Water retention structures and dumps will have specific groundwater monitoring infrastructure installed
- Site water balance data, including pumping, rainfall and stream flows, will be maintained in a suitable format
- Water levels will continue to be monitored on a seasonal basis in groundwater monitoring bores on site.

4 Water Account

4.1 Water account

The water accounting maintains the format as presented in prior years. Vista Gold will commence water accounting as per the *Water Accounting Framework for the Minerals Industry. User Guide Version 1.2 – April 2012* upon commencement of mining operations.

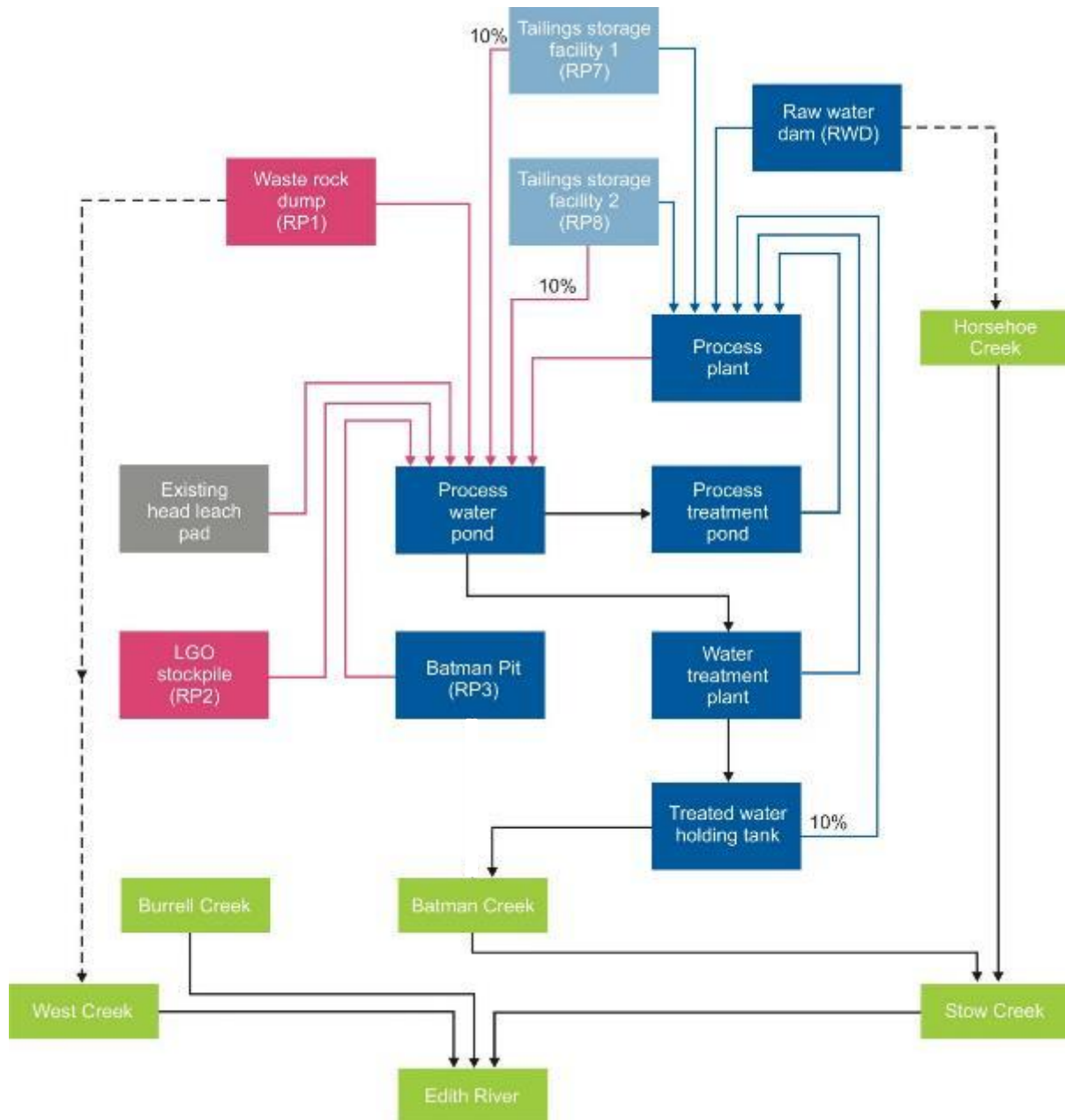

Figure 4-1 Site Conceptual Mine Water Discharge Model

4.2 Water account for operations

The volume of water treated in the WTP and in the WTP TWHT will have the largest impact on water accounting for the future. The amount of water, which can be discharged from site, will largely be dictated by:

- The quality of the treated water within the TWHT
- The date by which the quality is achieved
- The time taken to receipt results and approvals from DTAs
- The flow volumes in the Edith River
- Any down time due to servicing or failures of the pumping infrastructure

4.3 Water account for mining operations

Based on the recently reviewed Hydrology Report, the water balance shows that generally all water on-site will be required for use in the ore processing plant. However, there is capacity for the site to discharge excess treated water through the WTP to the Edith River. This will occur in times of high rainfall and the model shows that the likelihood of this occurring in the first year of operations is high.

4.4 Water extraction licence

The current management aim of the site is to reduce the water inventory to enable mining to recommence. Water extraction from either ground or surface water sources is not expected to occur until after processing commences.

The project has been issued with a "Licence to Take or Use Surface Water" Licence No" 8141014, issued 11th Jun-21. This facilitates up to 3.48 GL annually.

5 Risk Management

A risk assessment workshop held jointly by GHD and Vista Gold in February 2017, reviewed and updated the risk assessment produced for the 2013 EIS. **Section 5.2** lists that actions and response strategies for the identified risks and additional information is located in Appendix T of the MMP.

Subsequent to the risk assessment workshop a hydrogeological report was updated by Tetra Tech (Appendix A11 of the MMP) and reviewed by GHD. No new risks to groundwater were identified through the review process in the updated report. Therefore, the groundwater risks identified in the 2013 EIS risk assessment remain current as shown in **Table 5-1**. A review and update of all other identified risks relating to water management was completed in February 2017 and are listed in **Table 5-1**.

5.1 Identify Hazards and Rank Risks

An extensive risk assessment of the care and maintenance operations is provided in the MMP. Operational activities are expected to be consistent with those activities historically undertaken and it is expected that the risks will remain similar. Therefore, the impacts and consequences identified in the MMP risk assessment are largely unchanged (Appendix T).

Table 5-1 lists the risks discussed during the 2017 risk assessment workshop, which relate to surface water management and groundwater risks. For more detail, refer to the risk assessment document (Appendix T).

Table 5-1 Identified Hazards Relevant to Water Management

Reference	Source of Impact / Potential event
Surface Water	
SW01	Major Flooding of significant structures such as mine pit, infrastructure and roads
SW02	Overflow from the retention ponds due to extreme rainfall event, pump failure
SW03	Severe rainfall event leading to AMD in surface runoff (disturbed) leaving site (e.g. leachate from WRD, HLP)
SW04	Physically altered surface flow regime including creek diversion effects
SW05	Failure of retention pond wall or WRD or creek diversion
SW06	Complete failure of the WTP during a significant storm event (1 in 5 yrs)
SW07	Spills of hazardous materials leading to entry into surface water and/or soil
SW08	Failure of TSFs
SW09	Diversion channel construction on Horseshoe Creek and Stow Creek
Groundwater	
GW01	Increase capacity of TSF1
GW02	Establishment of TSF2
GW03	WRD leaching, including seepage from existing and expanded WRD
GW04	Seepage of cyanide through HLP into localised / site groundwater system
GW05	Liquid and solid waste leaks and disposal, including chemicals
Acid and Metalliferous Drainage	
AMD01	Dewatering of Batman Pit to commence mining
AMD02	Dewatering of Batman Pit during mining
Waste	
WA01	Poor waste characterisation and / or Insufficient on-site supply of cover material for rehabilitation
WA02	Generation of putrescible waste, sewerage on-site and at the accommodation facility
WA03	Hydrocarbon and chemical spills and leaks
Closure and Rehabilitation	
CL01	Rehabilitation delayed beyond proposed schedule
CL02	Ineffective mine closure including insufficient TSF and WRD cover/thickness or general rehabilitation practices
CL03	Post mining (during closure) water management inadequate (i.e. passive water management fails)

5.2 Actions and Strategies in Response to Identified Risks

Whilst there continues to be an anticipated decrease to the volumes of treated water released during operations, the quality of the treated discharge water will still be required to meet thresholds and criteria specified under any future WDL. Such targets can largely be controlled through the adjustment of dilution rates to ensure environmental protection, as evidenced during discharges over the previous years.

It is important to note that the risk of decreasing AMD water storage capacity has been substantially reduced in recent years. This is due to the volumes of treated water discharged off site, the low annual received rainfall volumes and increased direct evaporation, all of which have resulted in a marked reduction in the net site water inventory. The dewatering of the site has further reduced this risk of exhausting AMD storage capacity.

With the significant reduction in pond levels in recent years, the available storage capacities of both RP1 and TSF1 are currently at their highest. Whilst the quantity and frequency of rainfall events remains the primary threat to capacity exhaustion of these ponds, the additional storage capacity lowers this risk.

The commencement of operations will further reduce the water inventory on site, with ore processing utilising all excess water on-site.

Impacts on community sentiment are of risk, not only to Vista Gold but also to DITT, due to the unique operating agreement for the site. Management of community expectations will require agreement on the on-site management actions and strategies and a clear and consistent communication of all site matters between Vista Gold and DITT.

For the actions and strategies listed in response to the identified risks listed above, refer to the risk assessment document (Appendix T in the MMP)

Table 5-2 Actions and Strategies in Response to Identified Hazards

Reference	Mitigation / Planned controls to manage risk
Surface Water	
SW01	<ul style="list-style-type: none"> • Significant mine infrastructure located outside 1 in 100 yr ARI flood design extent of creeks passing through the mine area • Construction of flood protection barriers / levees, or upgrading and redesign of existing ones • Diversion channels designed to keep velocities as per acceptable design criteria • Use of rip-rap protection on earthwork embankments adjacent to drainage channels • Creek and channel diversions to be constructed to meet 1 in 100 yr ARI flood event • Regular inspections of bunds and maintenance as necessary • Site safety procedures relating to extreme rain events and evacuation protocols – emergency response plan • Use of multiple bench elevations in the open cut • Alternate evacuation using on-site helipad
SW02	<ul style="list-style-type: none"> • Water retention ponds sized to capture an ARI (1 in 100) Wet Season rainfall appropriate to their hazard category • Maintain an appropriate freeboard allowance for sedimentation • Update Conceptual Site Model and ground contours of the SW of the site on a regular basis • Monitor (real time telemetry) and manage water levels in the retention ponds to maximise available storage capacity prior to the Wet Season – water management plan including GoldSim software • Discharge from site (if required) consistent with conditions of any future WDL in order to maximise storage capacity during major storm events • Capacity of WTP and equalisation pond sufficient to prevent overflows in normal operating conditions • If all water storages are at capacity, excess water will be redirected to the TSFs up to the height of beached tailings for temporary storage • Water retention ponds have been designed to overflow and discharge to the natural environment in periods of extreme rainfall, in order to protect the integrity of the structure • Develop and implement and review site Water Management Plan and align to regulations • Regular update of Water Balance Model (GoldSim) • Surface Monitoring to update and validate Water Balance Model • Design and construction in accordance with ANCOLD for hazardous materials • Have spare parts for pumps on site (including maintenance program) • Increase the rate of treatment and discharge if uncontrolled release likely • Ongoing monitoring and evaluation of water quality and macroinvertebrate and fish community structure • Targeting sampling of refugia pools during the Dry Season to investigate to potential of groundwater seepage impacting the aquatic fauna

Reference	Mitigation / Planned controls to manage risk
SW03	<ul style="list-style-type: none"> • Treatment of water and consumed in the operation • Design drainage/seepage to flow into retention ponds • Monitor and Report discharge events in accordance with requirements set out in WDL • Wet Season release to the Edith River in consultation with NT EPA (maintain RP to maximise RP capacity) • Implement and review of surface water monitoring program • Selective placement of potentially acid generating (PAG) rock, progressive encapsulation • Optimising pumping capacity • Reshaping of HLP for drainage control and reduce percolation • Relining of the moats around HLP to reduce seepage • Regular inspections and maintenance of drainage system • Regular checks of structures (blockage) and scouring protection • Erosion and Sediment Control Plan • Drain design to recognise 1 in 100 year flow events • Site water management plan • Tailings dam design (to ANCOLD guidelines) • Notify the NT EPA and / or DME in accordance with requirements of WDL and / or the MMP
SW04	<ul style="list-style-type: none"> • Adequate design to minimise environmental impacts • Monitor impacts to understand changes and respond to identified impacts
SW05	<ul style="list-style-type: none"> • Design to ANCOLD guidelines • Regular structural checks and maintenance • Design according to Western Australia and Northern Territory guidelines including benches, stormwater drainage, erosion and sediment controls • Immediate reconstruction of affected area • Develop a robust and fully implemented mine closure plan • Use of GCL • During detailed design material characteristics of waste will be addressed and appropriate design criteria (i.e. Factor of Safety)
SW06	<ul style="list-style-type: none"> • Regular checks and maintenance • Operations generating waste shut down as much as possible • Water Storage capacity to be maintained at a level to accommodate potential failure • Provide alternative temporary supply of potable water • Direct water to alternative storage area • Emergency release to the Edith River only conducted in consultation with NT EPA

Reference	Mitigation / Planned controls to manage risk
SW07	<ul style="list-style-type: none"> • Design, storage and handling of hazardous materials to Australian standards and regulations (secondary containment) • All hydrocarbons will be stored and handled in accordance with the bunding requirements of AS 1940:2004: The Storage and handling of combustible and flammable liquids • Consult with NT WorkSafe and DITT for hazardous material advice • Minimise quantities held on site • Spill clean-up procedures developed and implemented • Regular inspections of storages, tanks and bulk containers and the integrity of bunded areas and containment systems • Testing for chemicals included in surface water monitoring program • Spill register • Address hazardous materials storage within the final site Environmental Management Plan (EMP) • All hazardous materials will be transported in compliance with Dangerous Goods legislation • Appropriate training for relevant employees
SW08	<ul style="list-style-type: none"> • Design new TSF to ANCOLD guidelines • Protection of toe of TSFs through construction of diversion drains and installation of rock armour (new and old TSF) • Regular structural checks and maintenance • Formulate, develop and implement tailings dam management plan • Use of piezometers to monitor phreatic loads • Fully implement mine closure plan • Installation of emergency spillway to ensure water is not against dam wall • Specific item in the emergency response plan, including potential ANFO plant located downstream of TSF
SW09	<ul style="list-style-type: none"> • Prior to construction existing and proposed site drainage patterns will be identified • Implement a revegetation plan prior to creek diversion to suit the physical characteristics and requisite environmental values of the waterway • Incorporate appropriate materials into the design to achieve the requirements for habitat creation • Stabilise banks, including appropriate native plantings, to consolidate banks post-construction and restore habitat to current, or improved, condition • Any diversion will be constructed using clean non-erodible material • Post-construction monitoring to assess creek bank remediation measures • More detailed modelling at lower 'normal' flow conditions will be undertaken in order to assess the associated hydraulic impacts on fish passage • Consider fish passage in the design and provide sufficient depth, velocities and resting habitat in the diversion design for regular flow events • A clearly definable site boundary will be delineated (where practicable), with construction and vegetation clearance not occurring outside of this area Site entry and exit points will be clearly defined • Works will be scheduled so that construction coincides with periods of low flow and low rainfall • Implement site induction program

Reference	Mitigation / Planned controls to manage risk
	<ul style="list-style-type: none"> • Implement sediment control measures (such as silt curtains within the river channel) to minimise the potential for sediments to deposit on downstream foraging areas • Avoid stockpiling of soil along existing drainage lines, keep vehicles to tracks and divert storm water away from disturbed areas to minimise soil loss • Minimise the area of exposed ground and conduct excavation in stages to minimise ground exposed to erosion • Use existing crossings to move equipment across the waterway If there is no crossing, machinery should be carefully ‘walked’ across the waterway • If frequent crossings are required, lay a pad of clean rock at a shallow point of the waterway to make a temporary crossing. Remove temporary crossings when works have finished • Develop contingency measures to prevent flooding of the worksite by a rapid rise in the creek • Control erosion at the works site using slope stabilisation, revegetation, soil coverings, rip-rap and armouring, check dams, sediment traps, brush barriers and vegetation filters as appropriate • Implement spill control measures • Store and transfer petroleum products and other hazardous substances away from waterway in a bunded storage facility • Use non-toxic hydraulic fluids, such as vegetable-based fluids if possible • All equipment will be inspected and repaired regularly to prevent oil and other fluids leaking • If equipment is to be immersed in the waterway, it will be cleaned beforehand to remove any external grease, oil and other fluids • Dirt and mud will be removed from all equipment before entering the works site and waterway to avoid transferring weeds and disease • Wash-down water will not be allowed to enter waterways • Any cast-in-place concrete will be isolated from the waterway for at least 48 hr to allow pH to neutralise • If using wood treated with preservatives, the chemicals will be given enough time to fix before immersing the wood in the water • A macroinvertebrate monitoring program will take into account the location of potential sources of impact, the large inputs of rain during the Wet Season and the necessary level of statistical power to detect change in macroinvertebrate communities
Groundwater	
GW01	<ul style="list-style-type: none"> • Monitoring of bores that are potentially influenced by groundwater drawdown including neighbouring properties (Werenbun and Edith River) • Data to be assessed and summarised yearly within the Water Management Plan • Bores that do not meet the minimum construction requirements for water bores in Australia will be decommissioned or rehabilitated in accordance with the guidelines • Exploration drill holes that may act as conduits interacting with mine features will be considered for rehabilitation • Monitoring of bores potentially influenced by groundwater drawdown • Alternative water supply provided if impact to water supply detected

Reference	Mitigation / Planned controls to manage risk
GW02	<ul style="list-style-type: none"> • Reuse existing TSF1 underdrainage system and associated infrastructure to reduce seepage to groundwater prior to expansion and operation, reducing future risk • Rehabilitation of monitoring bores proposed to be retained, to meet most current Minimum Construction Requirements for Water Bores in Australia; and closure of redundant bores and / or grouting of exposed exploration drill holes • Monitoring of water levels and quality adjacent to TSF1 to establish if there is a linkage with TSF1 and the surrounding environment • Data to be assessed and summarised yearly within the Water Management Plan • Tailings will be managed in accordance with the Tailings Management Plan
GW03	<ul style="list-style-type: none"> • TSF2 will be designed, constructed and rehabilitated in a manner that will minimise oxidisation of sulphides and leakage of contaminated liquor or leachate; • TSF2 construction and materials are designed for the complete lifecycle of the mine • TSF2 will be underlain by a system of under-drains, geo-membrane liner, toe drains and over-drains, completely seal system with no connection between TSF2 and underlying groundwater • Bores to be constructed and monitored bi-annually for depth and quality to assess potential interaction between TSF2 and the surrounding environment • Tailings will be managed in accordance with the Tailings Management Plan
GW04	<ul style="list-style-type: none"> • Existing WRD will be encapsulated within the expanded waste rock dump • Investigate alternative methods of neutralising PAG rock (e.g. anoxic limestone drains) • AMD materials selectively handled to remove oxygen and water • Waste Rock Dump will be managed in accordance with the Waste Rock Management Plan • RP1 will continue to collect any AMD drainage • Implementation of the Groundwater Monitoring Program • Detailed analysis and design of expanded waste rock dump • Construction of 8 m wide benches at 30 m vertical intervals to collect stormwater drainage and provide access for closure cover installation, reclamation activities and maintenance. Stormwater collected on benches will be conveyed to surface water collection ditch • A surface water collection ditch will be constructed down gradient of WRD to collect flows for treatment prior to discharge • PAF rock will be contained in a NAF shell reducing exposure to air and water during operations and post mining • Monitoring of water levels and quality adjacent to WRD to establish if there is a linkage with the WRD and the surrounding environment. Data to be assessed annually and summarised annually within the Water Management Plan • Installation of GCL progressively throughout closure of areas of the WRD. The installation of the GCL will reduce / eliminate infiltration and generation of AMD in the structure • Detailed analysis and design of expanded waste rock dump

Reference	Mitigation / Planned controls to manage risk
GW05	<ul style="list-style-type: none"> • Processing or rehabilitation of heap leach materials • Ongoing maintenance of heap leach post Wet Season • Cleaning of moat and repairs of liners as required • Pumping of stormwater from HLP to TSFs • Monitoring of water levels and quality adjacent to HLP to establish if there is a linkage with the surrounding environment. Data to be assessed and summarised yearly within the Water Management Plan
GW06	<ul style="list-style-type: none"> • Manage disposal of wastes in accordance with the Waste Management and Pollution Control Act and waste management hierarchy in the Hazardous Waste Management Plan • Chemical and hydrocarbon storage facilities bunded and managed in accordance with Mine Management Plan including inventory of chemicals on-site, material safety data sheets, spill kits and spill response procedures
Acid and Metalliferous Drainage	
AMD01	<ul style="list-style-type: none"> • Continue treating Batman Pit waters if required • Ongoing monitoring of water quality
AMD02	<ul style="list-style-type: none"> • Collection and treatment of AMD pit waters resulting from incidental rainfall in Batman Pit, if required • Treated Batman Pit water to be reused as process water
Waste	
WA01	<ul style="list-style-type: none"> • Adequate waste rock characterisation • Schedule waste rock placement to ensure adequate encapsulation • Monitor GCL effectiveness and modify as appropriate • Ensure sufficient capacity in downstream retention ponds (RP1 and equalisation pond) • Implement WRD management plan • Provide ongoing refinement of materials balance • Increase contingency for cover requirements • Construction of surface and sub-surface drainage and implementation of a water management plan for contaminated water • MMP includes Water Management Plan
WA02	<ul style="list-style-type: none"> • Waste management addressed in EMP • Separation of waste for recycling and recovery • Removal of residual waste to landfill • Disposal of hydrocarbon and other chemical spills to approved facilities • Record waste types and volumes generated on-site and being transported off-site • Monitor for potential environmental impacts by conducting surface water quality monitoring on site • Treatment of sewage via a wastewater treatment plant

Reference	Mitigation / Planned controls to manage risk
WA03	<ul style="list-style-type: none"> • Manage disposal of wastes in accordance with the Waste Management and Pollution Control Act and waste management hierarchy in the Hazardous Waste Management Plan • Ensure hazardous materials are used, stored and disposed of correctly i.e. chemicals used in gold processing will be stored in a secured compound near the process plant in compliance with, AS 1940-2004: (The Storage and Handling of Flammable and Combustible Liquids), AS 3780-2008: The Storage and Handling of Corrosive Substances. National Standard for the Storage and Handling of Workplace dangerous goods NOHSC: 1015 (2001), AS/NZS 4681: The Storage and Handling of toxic substances and AS/NZS 3833: 2007: The storage and handling of mixed classes of dangerous goods in packages and intermediate bulk containers. • Materials are used as instructed on Safety Data Sheets (SDS); • Appropriate spill kits and equipment and spill response procedures are in place. • Implement secondary containment as a minimum requirement.
Closure and Rehabilitation	
CL01	<ul style="list-style-type: none"> • Closure and Rehabilitation Plan updated and refined throughout mining operations including life of mine closure planning, contingency planning, tailings management plan, waste rock management plan and a care and maintenance plan • Revegetation and weed management trials to determine best practice for revegetation of the site • Progressively rehabilitating the mine reducing the environmental and financial risk of closure • Annual review of security bond calculations
CL02	<ul style="list-style-type: none"> • Closure and Rehabilitation Plan updated and refined throughout mining operations including life of mine closure planning, contingency planning, tailings management plan, waste rock management plan and a care and maintenance plan • Engagement with Northern Territory Government regulatory authorities on plans to leverage off other projects • Thickness of rock armouring to ensure integrity of the cover to be reviewed during progressive rehabilitation and updated as required • Revegetation and weed management trials to determine best practice for revegetation of the site • Progressively rehabilitating the mine reducing the environmental and financial risk of closure • Under the Water Management Plan and Closure and Rehabilitation Plan implement and maintain a passive water treatment system • Annual review of security bond calculations
CL03	<ul style="list-style-type: none"> • Closure planning progressively refined over the life of mine including e.g. passive water treatment system, • Vista Gold will maintain responsibility until Northern Territory Government accepts relinquishment and security bond refunded

6 Management

6.1 Management of Issues

The sections below cover the issues related to Water Management for the MTPA. For consistency with the previous sections of the WMP, these management issues have been separated into surface water management issues and groundwater management issues.

6.2 Surface Water Management Issues

6.2.1 Potential contaminants

The MTPA is a brownfield site, with various sources of potential contaminant generation. The geologic host is a hard, competent greywacke (silicified shale) containing small quantities of various sulphide minerals which, in addition to hosting gold and silver, also host a variety of other metals including iron, copper, lead, zinc, aluminium and cadmium. Surface water flows on the MTPA are a direct result of the seasonal rains during the wet season and are the prime mechanism in the rapid mobilization and transport of potential contaminants.

As the sulphide minerals are exposed to the atmosphere, a decomposition (or oxidation) of the mineral can occur. The result of this oxidation is the liberation of metal ions and combination of sulphur with oxygen to form sulphate. Generally, this reaction is superficial, the speed of which is driven by the surface area available in combination with environmental conditions such as temperature and available oxygen. Water provides the transport mechanism to wash the oxidized material away and provide a clean surface for the reaction to restart. Water itself may be an additional source of oxygen for the reaction resulting in an excess of free hydrogen ions, which can react with the liberated sulphate ions to form sulphuric acid. The lower pH contributes and often accelerates the speed of the reaction. The sulphide minerals present in the Mt Todd deposit include iron sulphides (pyrite and pyrrhotite), copper sulphides (bornite, covellite, chalcocite and chalcopyrite), zinc sulphide (sphalerite) and lead sulphide (galena).

In addition to the liberation of metal ions and the generation of acid through the oxidation of sulphide minerals, mined rock may also have various nitrogen/oxygen (NOx) compounds present as residues from extractive blasting operations or from the degradation of cyanide used in the heap leaching or milling processes. Such contaminants are generally present in specific areas and are remnants from past mining operations.

6.2.2 Potential impacts

The potential impact of any unrestricted combining of site-contaminated surface water flows with regional surface water flows is the obvious deterioration of water quality. The magnitude of impact being in direct relation to the duration of exposure and levels of contaminants present. The MTPA is not the only source of the metals and compounds discussed in the previous section. There are background metals and compounds that can be identified in water quality analysis results upstream of the MTPA arising either from historical sporadic mining activities or naturally from the area's mineralized geology. The distinction lies in the higher concentration of these contaminants in the mine sites surface flows.

Undiluted and untreated, contaminated flows from mine contact water have the potential to impact aquatic life and downstream users in the Edith River ecosystem, local soil and groundwater, and the various flora and fauna which reside within the local area. Heavy metals

have the ability to enter the food chain through a variety of pathways such as direct ingestion by benthic filter feeders, adsorption into tissue through cell walls, uptake by plants and the subsequent consumption of contaminated prey and plants by higher order feeders. Stock and domestic drinking water may no longer meet the necessary health limits, recreational uses of the river such as fishing may cease, and other non-direct impacts to downstream human activities may arise. However, due to the management of the treated water discharged off-site and stormwater management adverse impacts to the downstream ecosystem and end users is unlikely to occur and routine monitoring has shown that no impacts from the mine site discharge have been detected in the Edith River.

A detailed identification and assessment of the risks from potentially contaminated surface waters at the MTPA (summarised in **Section 5**) and is located in the MMP (Appendix T)

6.2.3 Legislative requirements

Previous to the dewatering of Batman Pit, the site water discharge was managed by WDL 178 which was reissued routinely for the MTPA. The WDL permitted the release of treated water from Batman Pit at the authorised discharge point, located in Batman Creek to the Edith River.

The WDL was the dominant legal instrument in relation to water release activities and set forth the expectations of Vista Gold. However, due to the dewatering of Batman Pit resulting in no further discharge of treated water from the site, the WDL has been rescinded by DEPaws.

6.3 Groundwater Management Issues

6.3.1 Potential contaminants

The various potential contaminants as discussed for surface waters in **Section 6.2** also have the potential to enter groundwaters. The extent to which this is occurring at the MTPA is largely driven by:

- The measures taken during construction of retention ponds, waste rock and ore stockpiles to minimise groundwater seepage.
- Such measures are known to exist for the HLP and RP5 where impermeable plastic linings were installed as part of their construction, for TSF1 in the form of the underdrainage network and soil improvements, but for other structures such as RP2, RP1 or the stockpiles, no specific measures are known.
- The effectiveness of the seepage barriers/control systems.
- The groundwater monitoring results infer a possible compromise in the lining of the HLP, and the closure of the underdrainage system over the past 10 years is likely to have increased seepage rates below TSF1, however, current groundwater data does not support any adverse impact on groundwater quality beneath TSF1.
- The porosity and transmissivity of the geologic host rock to date suggests that groundwater aquifers below the site are generally composed of water within the cracks and fractures of the rock with the weathered upper geological layer playing a greater role in localised recharge and discharge. Hydraulic conductivities are generally low but notable in specific locations such as the surface seeps below RP1 and TSF1.

Other minor contaminants could include the various hydrocarbons or chemicals such as herbicides if managed inappropriately. The likelihood of these contaminants entering the ground

waters at MTPA is very low due to the small volumes maintained and utilised on site and the presence of appropriate storage and handling procedures.

6.3.2 Potential impacts

The primary impact of contaminated ground water is the reduction in water quality for other surrounding groundwater users and the contamination of surface water streams, rivers, lagoons if groundwaters are released to the surface via springs, and other groundwater sinks.

While the potential contaminants are significant, for the MTPA the general conclusion from investigations to date, suggest that there exists limited ability for such contaminants to travel significant distances. This attenuation of transport exists throughout the majority of the site, particularly in higher areas where porous material is absent, and therefore restricting any potential impacts to the immediate area.

The Horseshoe Creek catchment below TSF1 is expected to be the area of most significant impact as a result from the cessation of correct Tailings Storage Facility management facilitating increased seepage. A number of bores below the TSF exhibit high concentrations of cobalt unequalled across the site however, surface waters within the Stow Creek do not exhibit characteristics consistent with the contamination and subsequent transport through the surrounding alluvium, indicating that there is no connectivity.

The neighbouring and regional land uses do not share substantial groundwater resources with the mine site, with the nearest neighbouring bores being over six kilometres away (upstream) at the Werenbun community and Edith Falls recreational area. Results from monitoring of down gradient bores approximately 500 m from RP1 has failed to identify any chemical signatures similar to that of the pond water. Results from dry season sampling of the Edith River also do not report elevated contaminants or evidence any information of direct groundwater contamination.

6.4 Remedial or Corrective Management Actions

The remedial or corrective actions undertaken during the previous reporting period to address the management issues identified in **Section 6.2** are broken into those relating to surface water and those relating to groundwater and are detailed below.

6.4.1 Surface water management during previous period

Water management activities for the 2020-21 period largely remained consistent with goals of minimising uncontrolled discharges through a combination of on-site storage of contaminated waters, treatment of the contaminated waters contained in Batman Pit, and controlled (licenced) release of treated water from Batman Pit. This successfully resulted in the dewatering of Batman Pit.

All monitoring activities pursuant to WDL 178-8 and MMP for 2020-21 have been successfully completed. Surface water monitoring was undertaken on a monthly program for the period of reporting and daily during the December 2020 to March 2021 discharge period. Biological and sediment monitoring was conducted in April 2021.

Results of water quality monitoring demonstrate compliance with WDL reporting values. These results are presented in the WDL 178-8 Monitoring Report (SLR 2021).

Macroinvertebrate and sediment sampling each year has not revealed any statistical differences in macroinvertebrate populations related to the discharge water quality. The 2021 sampling has

included an additional monitoring site in Stow Creek upstream of the proposed TSF2, however, this was unable to be accessed in 2021 due to safety issues.

Sediment chemistry was relatively consistent across all sites and is reflective of non-mining related catchment mineralisation. No values exceeded SQG low concentrations.

6.4.2 Controlled releases

Controlled releases since 2013 have seen a >70% reduction in water inventory on site.

The respective monthly discharge reports required by the WDL are available on the Mt Todd website and provide additional detail on each of the discharge events occurring between 2013 and 2021. <http://www.mttodd.com.au/waste-discharge-licence.html>

6.4.2.1 Infrastructure

To date the following major Water Management Infrastructure activities were undertaken:

- Modifications to RP2 pipelines to allow connection of the mobile diesel pump to enable parallel pumping from RP2 without changing over lines i.e. now bolted in place and using valves instead of the need to unbolt lines etc.
- Modification and installation of pipelines to permit direct transfer of water from RP5 to TSF1
- Annual remediation earthworks to the Heap Leach Pad
- Repairs and upgrades to electrical switchboard at the decant ponds for reliable power supply to the decant pumps
- Repairs to various on-site electrical distribution lines such as replacement of isolators and surge arrestors
- Minor earthworks such as repairs to drains and culverts
- Minor earthworks and repairs to surface water sampling access roads
- Poisoning and removal of weeds and vegetation growth from around pipelines and electrical transformers
- Removal of all shrubs and trees from the outer walls of the Tailings Facility
- Installation of a gauge board for the decant pond overflow pipe
- Installation of evaporation pipework on the Southern and Eastern crests of the Waste Rock Dump
- Repairs to the Batman Pit pumps and upgrades to the pump lube systems
- Repairs to the RP1 diversion drain

6.4.2.2 Projects

The small-scale trial of evaporation by irrigation in TSF1 provided the impetus to establish evaporation pipework on the southern and eastern crests of the waste rock dump. The trial was conducted to quantify the rates of additional evaporation, which could possibly be achieved on top of natural direct pond surface evaporation in an effort to identify a possibly dry season approach to the reduction of on-site AMD water. The results indicated that approximately $\pm 35\%$ of water pumped evaporated in the air and additional evaporation occurred via capillary action as water made its way back to surface when irrigation was not occurring.

Vista Gold extended the evaporation infrastructure to the catchment of TSF1 in 2017 dry season and did continue in the 2020 dry season. From the 2021 dry season and during operations, this method of dewatering will no longer be required.



Figure 6-1 Evaporation Infrastructure

Pumping of water from Batman Pit onto the outside edge of the Waste Rock Dump via misting sprays to enhance the evaporation is shown in **Figure 6-1**.

Real-time pH, EC and temperature measurements will be installed for the WTP TWHT discharge line and along with minor modifications to a future Waste Discharge Licence will enable confirmation of the monitoring philosophy during controlled releases from the TWHT.

6.4.3 Groundwater management during the previous period

No specific direct management or mitigation activities were undertaken on site concerning ground waters. No abstraction of ground waters was conducted other than that the small amount used for site facilities and care and maintenance activities from Bore 6. The recharge rates around this bore exceed demand and in the absence of any large-scale extraction or injection no drawdown monitoring or assessments are currently conducted.

The only reportable groundwater related activities for the period include –

- Routine monitoring of groundwater quality
- Ongoing review of the TSF1 acidity generation and migration study

These activities will continue during operations with the inclusion of any additional studies as determined subsequent to annual interpretation of groundwater data identifying potential issues.

7 Proposed Actions

7.1 Surface Water Management for Operations

The potential impacts for the future continue to be those identified in **Section 6.2**. Management challenges of treated water discharge from the TWHT and the operational water management activities will be similar during operations. The goal of water management is to ensure sufficient water for processing and to ensure compliance with all future licence conditions if active discharge of treated water is required.

7.1.1 Water pumping and release strategy

During operations, MTPA is expected to a zero-water discharge site as all water on site is expected to be utilised for ore processing. Any extra water on site not used for processing that may increase the risk of uncontrolled spills will be directed to the WTP for discharge after treatment to the Edith River via Stow Creek. This will usually be related to storm events. **Table 7-22** outlines the mining operations related water pumping and monitoring activities that will largely be adopted one mining commences.

Table 7-1 Annual water transfers and monitoring procedure: Care & Maintenance

Water Transfers	Monitoring
RP1	
Maintain freeboard by pumping untreated waters to RP7. December to February – pump to RP7 if freeboard is less than 2.5 m March to April – pump to RP7 if freeboard is less than 1 m Dry season – pump to RP7 if major rainfall is expected and freeboard is less than 0.5 m. Pump to enhanced evaporative system if there is capacity in the receiving areas.	RP1 level (daily during wet season) Flow to RP7 (cumulative and instantaneous). Pump infrastructure (weekly during the wet season)
RP2	
Maintain freeboard by pumping untreated waters to RP7.	RP-2 level (daily during wet) Flow (cumulative and based on pump running times) Pump infrastructure (weekly)
Batman Pit	
Pump to RP7 if water rising for more than 3 consecutive years. Pump to WRD and/or RP7 enhanced evaporative system if there is capacity in the receiving areas.	Batman Pit level (daily during wet) Flow (cumulative and instantaneous. Daily flow meter recording and pump operating times) Pump infrastructure (weekly)
Heap Leach Facility	
October to April – pump to RP7 if moat freeboard is less than 0.75 m Dry season – pump to RP7 if moat freeboard is less than 0.5 m and heavy rain is expected	Heap leach moat level (daily during wet) pH of sediment settling pond (daily during wet) Flow (cumulative and based on daily pump operating times) pump infrastructure (weekly)
TSF1 (RP7)	
If RP7 freeboard is less than 0.3 m pump to RP3 (Batman Pit)	TSF level (weekly) Flow to (cumulative and based on pump operating times)
RWD	
Supplies water as required for fire control and exploration programs Maintain level in Decant Ponds to protect liner (300 mm of freeboard should be maintained to allow for rainfall runoff)	RWD level (weekly)

Table 7-22 Annual water transfers and monitoring procedure: Operations

Water Transfers	Monitoring
RP1	
Maintain freeboard by pumping untreated waters to PWP. December to February – pump to PWP if freeboard is less than 2.5 m March to April – pump to PWP if freeboard is less than 1 m Dry season – pump to PWP if major rainfall is expected and freeboard is less than 0.5 m	RP1 level (daily during wet season) Flow to PWP (cumulative and instantaneous). Pump infrastructure (weekly during the wet season)
RP2	
Maintain freeboard by pumping untreated waters to PWP. Pump to PWP if freeboard is less than 2 m	RP-2 level (daily during wet) Flow (cumulative and based on pump running times) Pump infrastructure (weekly)
Batman Pit	
Pump to PWP if water is required for the PP.	Batman Pit level (daily during wet) Flow (cumulative and instantaneous. Daily flow meter recording and pump operating times) Pump infrastructure (weekly)
Process Water Pond	
Maintain freeboard by pumping to PP and WTP Pump if freeboard is less than 0.5 m Discharge to Batman Creek during heavy rainfall via the WTP	PWP level (daily during wet) Flow (cumulative and based on daily pump running times) Pump infrastructure (weekly)
Heap Leach Facility	
October to April – pump to PWP if moat freeboard is less than 0.75 m Dry season – pump to PWP if moat freeboard is less than 0.5 m and heavy rain is expected	Heap leach moat level (daily during wet) pH of sediment settling pond (daily during wet) Flow (cumulative and based on daily pump operating times) pump infrastructure (weekly)
TSF	
October to March – Pump untreated to PWP when water level is at base of spillway. April to November – Pump to PWP	TSF level (weekly) Flow to PWP (cumulative and based on pump operating times) Pump infrastructure (weekly)
RWD	
Supplies water as required for fire control, exploration programs, and the PP via the PWP Maintain level in Decant Ponds to protect liner (300 mm of freeboard should be maintained to allow for rainfall runoff)	RWD level (weekly)
WTP	
Receive, treat and discharge to Edith River pumped water from PWP when excess water is present on site	Flow (cumulative and based on daily pump running times) Influent (in line EC, pH) Effluent (in line EC, pH) Pump infrastructure (weekly)

7.1.2 Other known specific projects

The following specific water management projects are required for the operations phase at MTPA.

- Duplicate the pumping and pipework infrastructure for the water management and treatment at site as described in **Section 2.8.5**.
- Derive a Discharge Management Plan for discharge to Edith River from the WTP.
- Inclusion of new water infrastructure in monitoring programs.
- Undertake construction of eastern RP1 diversion drain in an effort to reduce the total volume of uncontaminated inflow to RP1 further.

7.2 Groundwater Management During the Upcoming Period

No specific activities in relation to groundwater management are proposed for the forthcoming life of mine plan other than the routine annual monitoring program and the addition of two new monitoring bores south of TSF2.

In anticipation of future site developments, extension of the monitoring program is currently being considered to collect additional baseline information from a range of additional existing bores across the site. These areas of consideration include:

- The historical “Quigley’s” area to the north of the TSF1
- The inclusion of monitoring bores installed during TSF1 acidity generation and migration study
- The resurrection and inclusion of other legacy bores currently abandoned and inoperable for various reasons.

An investigation will also be undertaken to determine the availability and suitability of any regional neighbouring bores for inclusion to the longer-term groundwater monitoring program.

An ongoing review of groundwater results will be conducted to assess the spatial temporal variations in quality and to inform more strategic approach to future groundwater sampling activities.

Two additional groundwater monitoring bores will be installed at the site south of TSF2 and existing bores have been added into the monitoring program.

8 Monitoring

The monitoring programs to be conducted during operations are detailed below and are in accordance with the relevant Vista Gold Standard Operation Procedure (SOP) along with the appropriate Quality Assurance and Quality Control Procedures based on relevant Australian Standards. Regulatory requirements are the primary drivers behind the annual routine water related monitoring programs, with additional monitoring programs implemented by Vista Gold for investigation and information gathering purposes.

The greater part of surface and groundwater monitoring activities currently and in future take place inside the existing mineral or exploration leases. The Jawoyn Aboriginal Corporation own the majority of surrounding lands with access and operational activities (such as necessary environmental sampling programs) permitted by the working agreements established between the Jawoyn Aboriginal Corporation and Vista Gold and certificate RI2021-28 issued by the AAPA, permitting a range of activities including routine environmental monitoring and management activities. Licenced external consultants are engaged to carry out aquatic related sampling (e.g. non-recreational sampling of fish and macro-invertebrate surveys) where specific permits are required.

8.1 Monitoring Programs

The monitoring programs that are currently conducted and that will be continued during operations include:

- Quarterly during Care & Maintenance and monthly during mining surface water monitoring (retention ponds, dams, rivers and creeks)
- Bi-annual groundwater sampling and monitoring
- Meteorological monitoring

8.2 Surface Water Monitoring

On-site staff complete the surface water monitoring quarterly during Care & Maintenance and monthly during Mining in accordance with the Surface Water Monitoring Standard Operating Procedure (SOP), which is updated on a regular basis. The surface water monitoring covers the retention ponds, dams, rivers and creeks located on-site and three locations offsite. The sites sampled will vary throughout the year as water levels and accessibility change and as operational (or legislative) requirements dictate.

Details of the current and proposed surface water sampling locations across the site are in **Table 8-1** and their respective locations illustrated in **Figure 8-1 Surface Water Sampling Locations**.

Table 8-1 Surface Water Monitoring Locations - Operations

Location	Description	Latitude	Longitude
SW2	Edith River upstream of mine	-14.17194471	132.1198981
SW3	Stow Creek Downstream of Batman Creek	-14.16143741	132.1185117
SW4	Edith River downstream of West Creek	-14.1706686	132.098347
SW4 (online)	Continuous real-time in situ	-14.141091	132.103209
SW5	Batman Creek downstream of mine	-14.14783263	132.1156704

Location	Description	Latitude	Longitude
SW7	Burrell Creek downstream of mine	-14.16533368	132.1079651
SW11	Horseshoe Creek downstream of mine	-14.13632611	132.1281727
SW12	West Creek upstream RP1 Spillway confluence	-14.16406393	132.1035284
SW13	Stow Creek upstream of Horseshoe creek confluence	-14.15605208	132.129894
SW14	Stow Creek below HLP drain confluence	-14.15702332	132.1244979
SW15	Edith River upstream Burrell Creek confluence	-14.17148983	132.1069033
SW16	Stow Creek upstream site of TSF2	-14.14703	132.15608
RP1	Retention Pond 1	-14.16306406	132.1072276
RP1 Spillway	Water from RP1 when discharging via spillway	-14.16334286	132.1046916
WRD Weir 1	Weir 1 on southern Toe of WRD	-14.15497097	132.1112862
WRD Weir 2	Weir 1 on southern Toe of WRD	-14.15506615	132.111596
WRD Weir 3	Weir 1 on southern Toe of WRD	-14.15492912	132.1051241
RP1 Siphon A	Discharge point 1 from primary siphons	-14.16355	132.1073844
RP1 Siphon B	Discharge point 2 from primary siphons	-14.16355215	132.1074238
RP2	Retention Pond 2	-14.13900123	132.1105751
RP2 Spillway	Water from RP2 when discharging via spillway	-14.13848504	132.1103263
Batman Pit	Batman Pit	-14.14032773	132.1026623
PWP	Process Water Pond	-14.14157675	132.1129599
TSF1	Tailings Storage Facility 1 (formerly TSF1)	-14.12763543	132.1174275
HLP	Heap Leach Pad	-14.14085911	132.1198629
RWD	Raw Water Dam	-14.12312228	132.1320079
PWP	Process water pond (previously RP5)	TBA	TBA
PRP	Process retention pond	TBA	TBA
TSF2	Tailings storage facility 2	TBA	TBA
TWHT	Treated water holding tank	TBA	TBA

8.2.1 Physical and Chemical Parameters

Table 8-2 shows the water quality parameters assessed for the water quality monitoring sites. Surface water sampling locations are shown in Figure 8-1.

Table 8-2 Surface water physical and chemical parameters

Physical		
Temperature		
Physico-chemistry		
pH	Electrical conductivity	Dissolved oxygen
General chemistry		
Ammonia as N	Bicarbonate Alkalinity as CaCO ₃	Calcium
Carbonate Alkalinity as CaCO ₃	Chloride	Cyanide (free, total and WAD)
Hardness	Magnesium	Nitrite
Nitrate	Potassium	Sodium
Sulfate	Total suspended solids	Total dissolved solids

Metals (total and 0.45 micron filtered)		
Aluminium	Boron	Cadmium
Chromium	Cobalt	Copper
Iron	Lead	Lithium
Manganese	Mercury	Nickel
Zinc		
Total recoverable hydrocarbons		
TRH C10 – C36		

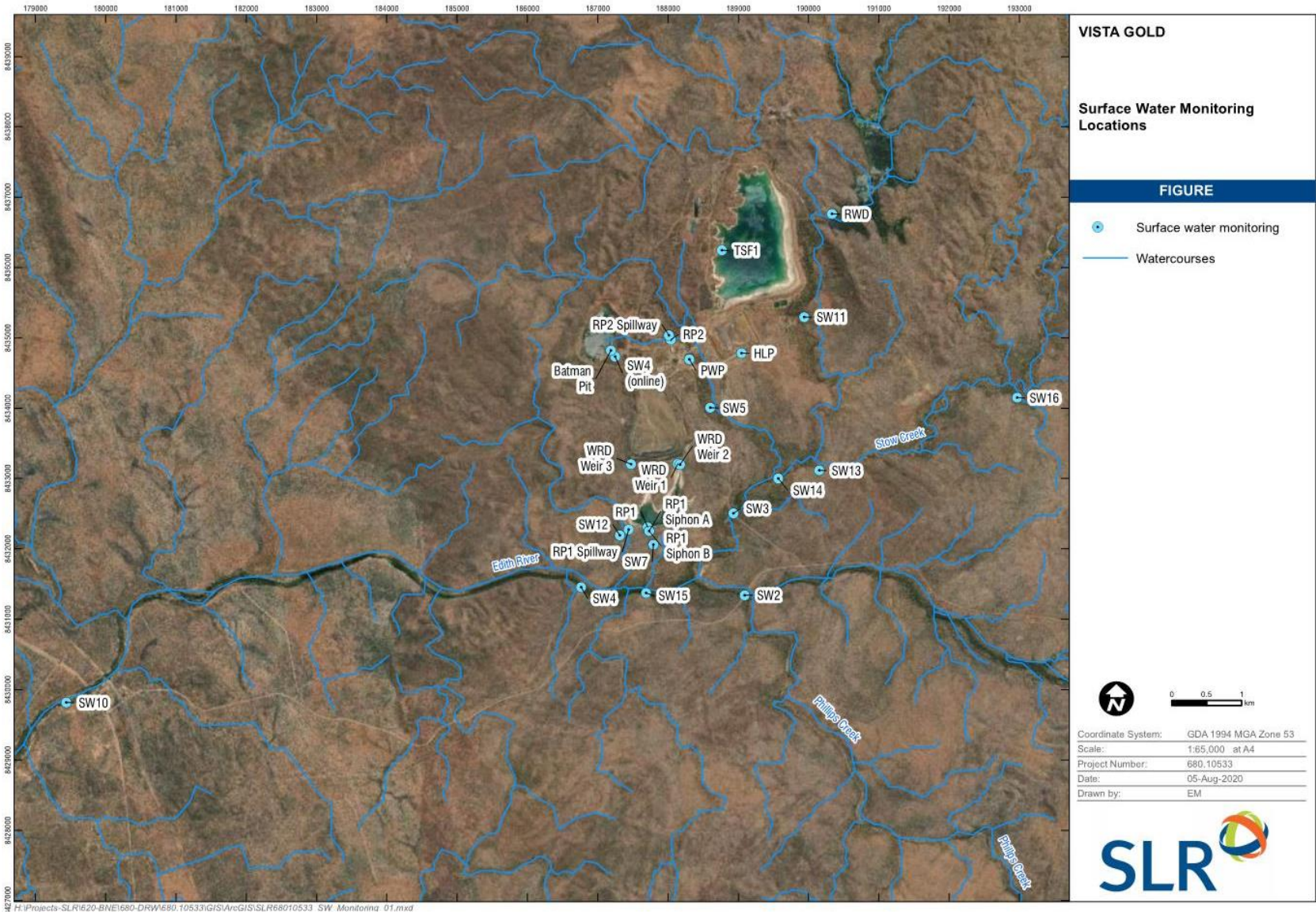

Figure 8-1 Surface Water Sampling Locations

8.2.2 Surface Water sample analysis and assessment

The collection of surface water samples for physical and chemical measurements from the majority of surface water monitoring sites occurs quarterly during Care & Maintenance and monthly during Mining (access and flow will determine which sites are suitable for monitoring). All collected surface water samples are sent to a NATA accredited laboratory for analysis.

Water quality data from all on-site surface water sampling locations is stored within the site water quality register. Data from site-specific surface water sampling sites is used for internal purposes or when needed to provide clarification for a specific site/area management regime if required. Analysis and interpretation of this data occurs on a routine basis.

The analyte concentrations are assessed against seasonal variations and historic values to provide an indication of potential changes in surface water quality. A trend analysis is conducted to monitor any upward trends in analyte concentrations in natural surface waters. If an upward trend is identified, further investigations will be conducted following the Trigger Action Response Plan (TARP). The specifics of the program may change over time to address any changes in the surface water monitoring needs of the site and company.

8.2.3 Trigger Action Response Plan

A Trigger Action Response Plan (TARP) has been developed for providing directions on requirements if a significant increase in metal concentrations in natural waterways is detected. **Table 8-3** shows the TARP for surface water investigations.

Table 8-3 TARP for SW4 non-compliance

Trigger	Action	Response
An investigation is triggered if: There is a non-significant upward trend ($r^2 > 0.5$) (or downward trend for pH) in dissolved metal concentrations using historical data at the sampling site. (greater than 5 sample points are required for a trend analysis in ESDAT)	On becoming aware of upward trend, conduct further investigation of source of metals within the surface water.	Initiate investigation Assess CoC, laboratory data and duplicate samples. Discuss results with laboratory. Assess data against historical Conduct additional sampling to confirm source of exceedance if required. Confirm elevated analyte are due to mine activities. Review Monitoring program. Based on the outcome of the investigation a mitigation or management measure will be adopted to mitigate or prevent environmental impacts. Examples of what will be considered as part of this process have been provided in Section 8.2.4 .

8.2.4 Proposed mitigation measures

If an increase of the concentrations of analytes associated with mining activities is exceeded the proposed investigation will provide guidance on the most appropriate mitigation or improvement measures to be taken. For surface water this will include consideration of one or all of the following actions.

- The prevention of active or passive discharge off site, achieved by
 - Ceasing active discharge
 - Reducing water levels in water holding structures to reduce or arrest seepage
 - Diverting contaminated water into water holding structures with sufficient capacity
- Treating water to improve quality prior to active or passive discharge
- Diluting contaminated water with good quality water to increase the potential uses of the water across the site
- Treating water that has deteriorated and is no longer available for the proposed or intended use
- Managing contaminated sources to reduce or eliminate ongoing and future impacts
- Reducing water interception or storage to ensure that environmental flows are maintained

8.3 WTP Discharge

During operations, Vista Gold propose to discharge excess site water that has been treated to the Edith River via Batman Creek and Stow Creek. The majority of water on-site will be utilised in the ore processing plant, however, heavy rain events may result in excess water and potential overtopping of RPs. To manage any potential mine impacted water leaving site Vista Gold will treat the water prior to controlled discharge. The discharge water will be treated in the WTP to provide high quality water as described in **Section 2.8.1**.

8.3.1 Management and Monitoring of WTP Discharge

The discharge from the WTP will be managed using the same regime as that previously used for discharging treated water from Batman Pit. The water quality will be assessed for the same analytes as listed in ERROR! REFERENCE SOURCE NOT FOUND.. The water quality data will be used in the same dilution algorithm as described in the previous Discharge Management Plan. The flow rate in the Edith River will be used to determine the volume of water discharged from the TWHT so that water quality is maintained in the Edith River.

8.4 Groundwater Monitoring

Groundwater monitoring currently occurs on a 6 monthly basis across 16 bores and will continue at this frequency during mining operations. **Table 3-1** lists all bores selected for the operations bi-annual monitoring program, with the respective locations shown in **Figure 8-2**. New bores will be installed to monitor groundwater quality south of TSF2 with potential to impact the Edith River after detailed site drawings are provided. Two new bores are shown in **Table 8-4** (TSF2MB03 and TSF2MB04) with their preliminary locations. These will be confirmed upon installation. Currently, TSF2MB02 provides baseline data for groundwater that has the potential to be impacted by TSF2.

Table 8-4 Monitoring Bores for Operations

Bore Group	Bore Number	RN	Northing	Easting	Elevation
1	BW18P	RN026350	189861.874	8439232.408	140.64
1	BW19P	RN026149	188997.127	8438108.581	138.45
1	RN028926	RN028926	189992.456	8438278.191	145.52
2	BW29P	RN029363	188306.845	8431788.955	112.9
2	MB6D		187709.73	8432246.02	
2	MB6S		187714.2	8432246.7	
2	WDMB01		187284.96	8432583.78	124.16
2	SW04MB01		186767.924	8431559.732	11.64
3	BW6P*	RN026131	188893.019	8433988.369	121.54
3	MB1		188099.519	8434470.273	131.06
3	MB3		189158	8434624	
3	MB4		189468.862	8434893.873	129.57
4	MB5		189426.53	8435302.35	
4	TDMB1D		189381.372	8435351.568	124.56
4	TDMB2D		189887.907	8435549.062	123.87
4	TDMB2S		189882.008	8435544.065	124.07
4	TDMB3D		189937.183	8436307.725	125.32
4	TDMB4D		189497.626	8437339.708	132.44
4	TDMBD1		188670.07	8437099.535	143.16
5	TSF2MB01		191239.441	8436060.05	138.77
5	TSF2MB02		191608.559	8435084.255	141.36
6	TSF2MB03		190838.1	8432917	TBA
6	TSF2MB04		190254.7	8432120	TBA

* BW6P occasionally monitored for bacteriological and trace metal analyses to evaluate suitability for potable water

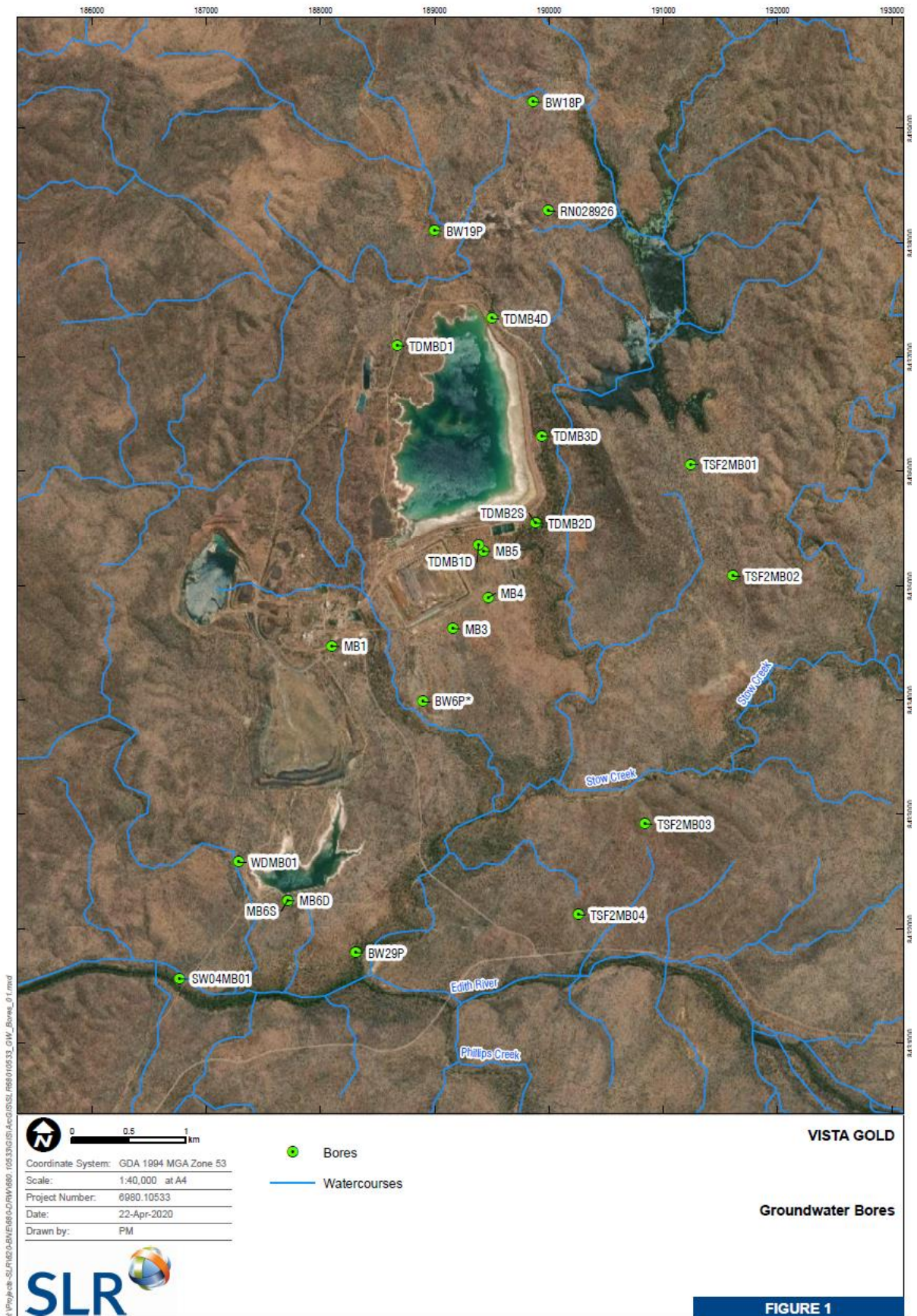

Figure 8-2 Groundwater Monitoring Bores

Table 8-5 Bore Grouping for operation

Grouping	Bores	Justification
1	BW18P, BW19P, RN028926	North of TSF1
2	MB6D, MB6S, BW29P, SW4MB01, WDMB01	South of RP1, shallow groundwater with potential to report to Edith River
3	MB1, BW6P, MB3, WDMB02, MB4	Processing area / Batman Creek
4	MB5, TDMB1D, TDMB2D, TDMB2S, TDMB3D, TDMB4D, TDMB1	Surrounding TSF1, detect impacts of TSF seepage on shallow and deep groundwater.
5	TSF2MB01, TSF2MB02	Between Raw Water Dam and TSF2
6	TSF2MB03, TSF2MB04 (locations to be confirmed)	South of TSF2 with potential to report to the Edith River

8.4.1 Groundwater sampling

Pumping and sampling of ground waters is conducted via a semi-automatic sampling system following Australian /New Zealand standard methods. While continuously monitoring the standing water level of the bore to minimise drawdown, groundwater is continuously pumped to the surface and passed through a flow cell where the physical parameters: standing water level, pH, electrical conductivity, turbidity, dissolved oxygen, Redox and temperature are continuously measured.

Flow rates are typically less than 1 L/min and regulated to achieve sufficient flow without overly disturbing the water above and below the screened zone. Pumping rate is matched to the bore re-charge rate by continuously monitoring the standing water level by a logged pressure sensor. When all physical parameters have stabilised the water is determined to be adequately representative of the surrounding “aquifer”. Water is diverted to the pre-preserved sample containers (via in-line filtration if necessary) and immediately cooled prior to dispatch to the laboratory. Groundwater is tested for the analytes listed in **Table 8-6**.

The analyte concentrations are assessed against seasonal variations and historic values is to provide an indication of potential changes in ground water quality. A trend analysis is conducted to monitor any upward trends in analyte concentrations. If an upward trend is identified, further investigations will be conducted following the Trigger Action Response Plan (TARP). The specifics of the program may change over time to address any changes in the groundwater monitoring needs of the site and company.

Table 8-6 Groundwater physical and chemical parameters

Frequency		
Bi-annual		
Physical		
Temperature	Electrical conductivity	Dissolved oxygen
pH	Standing Water Level	
General chemistry		
Ammonia as N	Bicarbonate Alkalinity as CaCO ₃	Calcium
Carbonate Alkalinity as CaCO ₃	Chloride	Cyanide (free, total and WAD)
Hardness	Total alkalinity as CaCO ₃	Magnesium
Nitrate	Total nitrogen	Dissolved organic carbon
TKN	Phosphate as P	Phosphorous - total
Potassium (total and dissolved)	Sodium	Sulfate
Nitrite	Thiocyanate	Total dissolved solids
Metals (0.45 micron filtered)		
Aluminium (total and dissolved)	Barium	Boron
Cadmium (total and dissolved)	Chromium	Cobalt (total and dissolved)
Copper (total and dissolved)	Iron (total and dissolved)	Lead (total and dissolved)
Lithium	Manganese (total and dissolved)	Mercury (total and dissolved)
Nickel (total and dissolved)	Strontium	Zinc (total and dissolved)

8.4.2 Trigger Action Response Plan for groundwater monitoring

A Trigger Action Response Plan (TARP) has been developed for providing directions on requirements if a significant upward trend in groundwater quality (including a downward trend for pH) is detected. **Table 8-7** shows the TARP for identified upward trends in groundwater.

Table 8-7 TARP for groundwater

Trigger	Action	Response
An investigation is triggered if: <ol style="list-style-type: none"> there is a non-significant upward trend ($r^2 > 0.5$) (or downward trend for pH) in dissolved metal concentrations and standing water levels using historical data at the sampling site. (greater than 5 sample points are required for a trend analysis in ESDAT) 	On becoming aware of upward trend, conduct further investigation of source of metals within the groundwater.	Initiate investigation Assess CoC, laboratory data and duplicate samples. Discuss results with laboratory. Assess data against historical Conduct additional sampling to confirm source of exceedance if required. Confirm elevated analyte or changes in standing water levels are due to mine activities. Review Monitoring program. Based on the outcome of the investigation a mitigation or management measure will be adopted to mitigate or prevent environmental impacts. Examples of what will be considered as part of this process have been provided in Section 8.4.3 .

8.4.3 Proposed mitigation measures

If a trigger value is exceeded the proposed investigation will provide guidance on the most appropriate mitigation or improvement measures to be taken. For groundwater this will include consideration of one or all of the following actions.

- Identify the source of the contamination. Manage source to prevent infiltration to groundwater.
- Conduct a risk assessment to determine the potential for impacts on environmental or human health.
- Manage contaminated groundwater to minimise contact with surface water and limit environmental exposure.
- Remediate groundwater if required.

8.4.4 Additional information

The ongoing groundwater monitoring will include:

- The monitoring of groundwater levels (and usage) on neighbouring properties (Edith Falls and Werenbun) and the subsequent development of a TARP manage any drawdown or contamination impact resulting from the proposed development
- The geochemical monitoring of a limited set of key groundwater bores (including those deemed 'background' or 'boundary' bores) will be continued on a bi-annual basis
- Water retention structures and dumps will have specific groundwater monitoring infrastructure installed if required
- Site water balance data, including pumping, rainfall and stream flows, will be maintained in a suitable format
- Groundwater levels will be monitored on a bi-annual basis in all groundwater monitoring bores on site upon commencement of operations.

8.5 Meteorological Monitoring

The current weather station was commissioned in mid-2011 to provide continuous on-site records for weather data in preference to relying on Katherine township data. The station is sited on the ridge to the west of the TSF1 scats pile. The weather station records the following meteorological parameters:

- Rainfall
- Wind Speed
- Wind Direction
- Solar Radiation
- Net Radiation
- Barometric Pressure
- Relative Humidity
- Air Temperature

Monitoring of site meteorological conditions provided by daily observations and telemetered data from the Mt Todd Weather Station. These results are compared with Katherine Bureau of Meteorology data.

9 Monitoring Program - Quality Assurance and Quality Control

Quality Assurance (QA) involves all of the actions, procedures, checks and decisions, undertaken to ensure the representativeness and integrity of samples and accuracy and reliability of analytical results (National Environmental Protection Council, 1999). Quality Control (QC) involves protocols to monitor and measure the effectiveness of QA procedures.

The QA/QC procedures outlined in the following sections are based on AS 5567.1 – 1998 and will be implemented during sampling.

9.1 Data Quality Indicators

To minimise the potential for unrepresentative data, the following Data Quality Indicators (DQIs) will be used to evaluate sampling techniques and laboratory analysis of collected samples:

- **Data representativeness** - expresses the degree which sample data accurately and precisely represents a characteristic of a population or an environmental condition. Representativeness is achieved by collecting samples in an appropriate pattern across the Project, and by using an adequate number of sample locations to characterise the site. Consistent and repeatable sampling techniques and methods are utilised throughout the sampling program.
- **Completeness** - defined as the percentage of measurements made which are judged to be valid measurements. The completeness goal is set as being sufficient valid data generated during the monitoring program. If there is insufficient valid data, then additional data are required to be collected.
- **Comparability** - is a qualitative parameter expressing the confidence with which one data set can be compared with another. This is achieved through maintaining a level of consistency in techniques used to collect samples and ensuring analysing laboratories use consistent analysis techniques and reporting methods.
- **Precision** - measures the reproducibility of measurements under a given set of conditions. The precision of the data is assessed by calculating the Relative Percent Difference (RPD) between duplicate sample pairs.

$$RPD(\%) = \frac{|C_o - C_d|}{C_o + C_d} \times 200$$

Where C_o = Analyte concentration of the original sample

C_d = Analyte concentration of the duplicate sample

A nominal acceptance criteria of 30% RPD for field duplicates and splits for inorganics will be adopted, however it is noted that this will not always be achieved, particularly at low analyte concentrations.

- **Accuracy** - measures the bias in a measurement system. Accuracy can be undermined by such factors as field contamination of samples, poor preservation of samples, poor sample preparation techniques and poor selection of analysis techniques by the analysing laboratory. Accuracy is assessed by reference to the analytical results of

laboratory control samples, laboratory spikes, laboratory blanks and analyses against reference standards. The nominal “acceptance limits” on laboratory control samples are defined as follows:

- Laboratory spikes – 70-130% for metals/inorganics, 60-140% for organics;
- Laboratory duplicates – <30% for metals/inorganics, <50% for organics; and
- Laboratory blanks – <practical quantitation limit.

Accuracy of field works is assessed by examining the level of contamination detected in field and equipment blanks. Blanks should return concentrations of all organic analytes as being less than the practical quantitation limit of the testing laboratory.

The individual testing laboratories will conduct an internal assessment of the laboratory QC program; however the results will also be independently reviewed and assessed.

9.2 Summary of Data Quality Acceptance Criteria

Data quality acceptance criteria adopted for this Project are set out in **Table 9-1**. These are generally based on the minimum requirements detailed in the Australian Standard AS4482.1-2005.

Table 9-1 Data Quality Acceptance Criteria

Measurement	Sediment	Water	Frequency	Acceptance Criteria	
				RPD (%)	Recovery (%)
Quality control samples to be prepared or taken on site (field)					
Blind field duplicate (BFD) samples (primary laboratory)	Yes	Yes	1 in 20 samples collected or 1 per batch.	30 or 50	-
Quality control samples to be prepared by laboratory					
Laboratory blanks	Yes	Yes	1 per batch.	-	-
Laboratory duplicates	Yes		1 in 10 samples collected or 1 per batch (whichever is smaller)	30	-
Matrix spike recoveries	Yes		1 per batch	-	70 to 130
Laboratory control sample spike recoveries	Yes		1 per batch	-	70 to 130
Surrogate spikes	Yes	Yes	Each analysis done by GC-MS (all organics except TPH C>10)		

Note: Water includes surface and groundwater.
Batches are the sum of samples collect throughout a sampling event (i.e. a batch can be collected over two days or more for groundwater).

9.3 Field Program

All field work will be conducted with reference to Australian Standards for the sampling of surface waters and groundwaters. Key requirements of these procedures are as follows:

- Decontamination procedures - including the use of new disposable gloves for the collection of each sample, decontamination of all multiple use sampling equipment

between each sampling location (using a phosphate free detergent and potable water) and the use of dedicated sampling containers provided by the laboratory;

- Sample identification procedures - collected samples will be immediately transferred to sample containers of appropriate composition and preservation for the required laboratory analysis. All sample containers to be clearly labelled with a sample number, sample location, sample depth (for groundwater) and sample date. The sample containers are then transferred to an ice filled cooler for sample preservation prior to and during shipment to the testing laboratory;
- Chain of custody protocols - a chain-of-custody form is to be completed and forwarded to the testing laboratory with each discrete batch of samples; and
- Sample duplicate frequency - field duplicates (blind) to be collected and analysed at a rate not less than ten per cent (i.e. not less than one duplicate per ten primary samples).
- Rinsate (equipment blanks) - Rinsate blanks will be prepared on site (consisting of pre-preserved bottles filled with laboratory-prepared water), exposed to the atmosphere and rinsed through decontaminated field equipment. These samples assess the efficacy of decontamination procedures.

9.3.1 Field Quality Control

Field quality control procedures will include the collection and analysis of the following:

- **Blind field duplicates (BFDs):** Comprise a single sample that is divided into two separate sampling containers. Both samples are sent anonymously to the primary Project laboratory. Blind duplicates provide an indication of the analytical precision of the laboratory, but are inherently influenced by other factors such as sampling techniques and sample media heterogeneity.

10 Data Review and Interpretation

This section provides a summary of the monitoring programs. Further information is provided in the WDL Reports located at <http://www.mttodd.com.au/waste-discharge-licence.html>

10.1 Surface Water

Surface water monitoring requirements during the dewatering of treated water from Batman Pit were specified in WDL 178. The results of this monitoring program conducted to 2021 were used to understand the influence of treated mine water discharged from the project area to the receiving environment in the Edith River system. The results of the monitoring program assisted in identifying trends to assess the success of the various surface water management measures implemented by Vista Gold.

10.1.1 Water Quality Trends

Site SW2 provides the background water quality for comparison with the Edith River downstream compliance site at SW4. All water quality data tables for the MTPA monitoring points are available upon request. **Table 10-1** shows the trend analysis for water quality from 2013-2021 wet seasons.

Table 10-1 Water quality trends 2013 -2021

Site	Analyte	Trend	R ²
Batman Pit		No significant or non-significant trends	
SW13		No significant or non-significant trends	
SW3		No significant or non-significant trends	
SW4		No significant or non-significant trends Significant downward trend for filtered nickel	
SW10		No significant or non-significant trends	
SW2		No significant or non-significant trends	

No significant trends were observed at the Mt Todd mine site from historical data 2013 – 2021, with the exception of a significant downward trend for dissolved nickel at SW4.

10.1.2 SW4 SSTV Exceedances 2020/21

SSTVs listed in WDL 178-08 are applied to the Edith River downstream compliance site, SW4, during the reporting period July 2020 to June 2021 (**Table 10-2**). It is important to note that SSTVs do not apply to other sampling sites in the catchments particularly standing water bodies such as Batman Pit.

Table 10-2 SW4 Exceedances July 2020 – June 2021

Analyte	SSTV WDL 178- 08	No.	Min	Med	Max	No. of SSTV exceedances during discharge	Reporting required
pH	6.0-8.0	96	6.2	6.3	6.9	0	No
EC μ S/cm	250	96	23	89	243	0	No
DO %sat	85-120	96	70	94	100	0	No
Major Ions (mg/L)							
Bicarbonate	319	27	5	9	20	0	No
Calcium	-	27	0.8	3.2	22	N/A	N/A
Carbonate	-	27	<1	<5	<10	N/A	N/A
Chloride	64	27	1	2	6	0	No
Magnesium	21	27	1.1	2.6	12	0	No
Potassium	-	27	<0.01	1	2.2	N/A	N/A
Sodium	-	27	1.7	3	5.8	N/A	N/A
Sulfate	129	26	2	21	120	0	No
Total Dissolved Solids	-	27	15	39	150	N/A	N/A
Nutrients							
Total Nitrogen	-	27	0.1	0.2	1.3	N/A	N/A
Total Phosphorus	-	26	<20	<50	60	N/A	N/A
TOC (%)	-	10	2	3	3	N/A	N/A
Metals (0.45 μm filtered) μg/L							
Aluminium	150	32	10	10	20	0	No
Cadmium	0.8	32	<0.1	0.1	0.8	0	No
Chromium	-	32	<1	1	1	0	No
Cobalt	13	32	<1	1	4	0	No
Copper	2.5	32	<1	1	14	3	Yes
Iron	350	32	15	145	360	Not discharging at the time elevated iron concentration reported	No
Lead	9.4	32	<1	1	1	0	No
Manganese	3,600	32	5	52	120	0	No
Nickel	17	32	<1	1	7	0	No
Zinc	31	32	1	11	140	5	Yes
Metals - total μg/L							
Aluminium	-	32	20	560	1,900	N/A	N/A
Cadmium	-	32	<0.1	0.1	0.8	N/A	N/A
Copper	-	32	<1	2	21	N/A	N/A
Iron	-	32	150	925	1,700	N/A	N/A
Other water quality parameters mg/L							
Cyanide (total)	0.007	32	<0.004	0.004	<0.005	0	No
TSS	-	26	<5	<10	12	N/A	N/A

Reporting Exceedances

WDL 178-08 Condition 47 states:

Condition 47 A non-compliance with this licence includes:

- 47.1 *an exceedance of a SSTV at SW4, as specified in Appendix 1, on two consecutive sampling occasions;*
- 47.2 *an exceedance of a SSTV at SW4, as specified in Appendix 1, of two times or more a trigger value on a single occasion; and*
- 47.3 *subsequent consecutive exceedances of the SSTV from an exceedance described in condition 47.1 and 47.2.*

Three non-compliances with Condition 47.2 of WDL 178-08 were recorded. **Table 10-3** summarises the exceedances of the SSTVs that were recorded at site SW4 (the compliance point), whilst discharge was occurring. All other parameters at the site SW4 were below the SSTV for the reporting period. SSTVs were exceeded at SW4 on five occasions. Four of these exceedances triggered a non-compliance with the WDL and an incident report was provided to the NT EPA on 28 January 2021. Additional discussion of results is provided below.

Table 10-3 Exceedances recorded at SW4 during discharge December 2020 - March 2021

Date	Monitoring Frequency	Analyte	Units	SSTV	Result	Action
28/12/2020	Weekly	Copper	µg/L	2.5	6	Incident report provided to NT EPA. Retesting of samples and dilution ratio changed from 1:25 to 1:168. Monitoring increased.
28/12/2020	Weekly	Zinc	µg/L	31	63	
29/12/2020	-	Copper	µg/L	2.5	14	
29/12/2020	-	Zinc	µg/L	31	140	
3/01/2021	Weekly	Copper	µg/L	2.5	6	
3/01/2021	Weekly	Zinc	µg/L	31	71	
31/01/2021	Weekly	Zinc	µg/L	31	36	
7/03/2021	Weekly	Zinc	µg/L	31	46	Minor exceedance. Dilution ratio increased from 24:1 to 30:1

10.1.3 Copper

As shown in **Table 10-3**, copper exceeded the SSTV at SW4 on 28 and 29 December 2020 and 3 January 2021. Dissolved copper was measured at 6 µg/L on two occasions and 14 µg/L on the third. The copper concentration triggered a non-compliance of WDL 178-08 under Condition 47.2 of WDL 178-08 as it was greater than two times the SSTV of 2.5 µg/L and an exceedance of the SSTV was reported on two consecutive sampling occasions.

Environmental impacts resulting from the SSTV exceedances are considered unlikely as evidenced by historical macroinvertebrate and ecotoxicology results sampled after similar metal exceedances. Further, this conclusion is supported by the 2021 macroinvertebrate, sediment and ecotoxicology data, which indicates that discharge of treated water from Batman Pit at current dilution ratios is not having a measurable impact on aquatic ecosystem health downstream of the mine site. The copper concentrations have not exceeded the SW4 SSTVs since 3 January 2021.

10.1.4 Zinc

The SSTV for zinc (filtered) (31 µg/L) was exceeded on five occasions during the 2020/21 reporting period. On 28 December 2020 zinc was recorded at 63 µg/L, 29 December 2020 it was 140 µg/L, on 3 January 2021 it was 71 µg/L (pumping ceased on 3 January 2021), on 31 January 2021 it was 36 µg/L and on 7 March 2021 it was 46 µg/L. The zinc exceedance on 28 and 29 December and 3 January triggered a non-compliance as it was greater than two times the SSTV of 31 µg/L and an exceedance of the SSTV was reported on at least two consecutive occasions. The zinc concentrations reported on 31 January 2021 (36 µg/L) and 7 March 2021 (46 µg/L) were not considered to be a non-compliance of the WDL as there were not more than two times the SSTV of 31 µg/L and zinc concentrations reported between the sample events were below the SSTV.

The lag between collecting a water sample and receiving water quality results relating to metals, means that immediate on-site management actions are not possible. The Vista Gold team review water quality results when received and adjust discharge dilution ratios as required. When pumping recommenced on 25 January 2021, zinc levels had returned to 13 µg/L which is below the SSTV. Give that the exceedances of the SSTV at SW4 were for a relatively short period of time during the end of December and early January 2021, it is unlikely that there was a significant environmental impact as a result. This is supported by the macroinvertebrate, sediment and ecotoxicology data, which indicates that discharge of water from Batman Pit at current dilution ratios is not having a measurable impact on aquatic ecosystem health downstream of the mine site.

10.1.5 Batman Pit Discharge Water Quality Results

Table 10-4 provides the summary of the treated water quality from Batman Pit for the 2020/21 wet season that was discharged into Batman Creek to enter the Edith River via Stow Creek. The ANZG (2018) stock watering guidelines are provided as a water quality comparison and are not a guideline value that the water quality is required to meet.

Table 10-4 Batman Pit Water Quality 2020/21

Analyte	SWG	Count	Minimum	Median	Maximum
Field Data					
pH	6.0-8.0	68	3.8	6.9	7.30
EC $\mu\text{S}/\text{cm}$	2,000	68	2,783	3,046	3123
DO %sat	-	68	83	95	110
Major Ions mg/L					
Bicarbonate	-	36	<5	20	26
Calcium	-	36	310	380	480
Carbonate	-	36	<1	<5	<10
Chloride	-	36	5	7	10
Sodium - Dissolved	-	36	33	49	220
Magnesium - (0.45 μm filtered)	-	36	21	210	250
Potassium - Dissolved	-	36	<0.01	8.8	9.8
Sulphate	1000	35	1,700	2,000	2,700
Total Dissolved Solids	-	36	1,500	1,700	4,100
Metals (0.45 μm filtered) $\mu\text{g}/\text{L}$					
Aluminium	5,000	30	10	50	8,800
Cadmium	0.8	30	0.9	9.7	38
Chromium	-	36	<1	<1	<1
Cobalt	13	36	4	38	9,700
Copper	2.5	36	<1	15	1,700
Iron	350	36	<1	10	880
Lead	9.4	36	<1	1	260
Manganese	3,600	36	1	570	3,000
Nickel	17	36	7	79	2,600
Zinc	31	36	<1	490	8,700
Metals total $\mu\text{g}/\text{L}$					
Aluminium	-	37	30	130	10,000
Cadmium	-	37	7.1	16	90
Copper	-	37	3	13	1,700
Iron	-	37	72	180	2,100
Nutrients $\mu\text{g}/\text{L}$					
Total Nitrogen	-	29	1.3	2.8	3.2
Total Phosphorus	-	28	<20	<50	60
Other water quality parameters mg/L					
Hardness (CaCO_3)	-	37	1,500	1,900	2,100
Total Suspended Solids	-	35	<1	<10	25
Cyanide (total)	0.007	10	<0.004	<0.004	<0.004

SWG = ANZG (2018) Stock Watering Guidelines

The EC is higher in Batman Pit than the Edith River, however, the EC at SW4 was still below the SSTV on all occasions.

10.1.6 SW2 Surface Water Quality Results

Site SW2 provides the background water quality for Edith River for comparison with the downstream sites SW4 and SW10. It is located upstream from the MTPA compliance point at SW4. Water quality data collected from SW2 is utilised to develop SSTVs and to determine the contribution of the surrounding environment prior to discharge inputs from MTPA at SW4. A summary of the water quality at SW2 for the 2020/21 wet season is provided in **Table 10-5**. The SSTVs have been provided in **Table 10-5** for comparative purposes only and are not applied to site SW2.

Comparing water quality at upstream reference site SW2 to the SSTVs that are applied to the compliance site SW4 is important in understanding the contribution that upstream water quality may be having on compliance at SW4. For example, iron is elevated in the background water quality and may have some contribution to downstream water quality in conjunction with the discharge of treated mine water from Batman Pit as the volumes of water contributed from SW2 to SW4 are much greater than that of the discharge.

The majority of results for metals have concentrations above the analysis limits of detection and suggest that the mineralisation in the surrounding environment has some contribution to the overall water quality in the receiving environment.

Table 10-5 provides a summary of the water quality at SW2 for the 2020/21 wet season.

The majority of metals with the exception of cadmium have concentrations above the analysis limits of detection and suggest that the mineralisation in the surrounding environment has some contribution to the overall water quality in the receiving environment. The SSTVs in **Table 10-5** are provided for comparative purposes only as SW2 is the background water quality site and it is prudent to compare the SSTVs that are applied to the compliance site SW4 to ascertain the contribution that upstream water quality maybe having on compliance at SW4. For example, aluminium, copper, iron, manganese and zinc are elevated in the background water quality and may have some contribution to downstream water quality in conjunction with the discharge of treated mine water from Batman Pit as the volumes of water contributed from SW2 to SW4 are much greater than that of the discharge.

Table 10-5 SW2 Water Quality

Analyte	SSTV	Count	Minimum	Median	Maximum
<i>Field Data</i>					
pH	6.0-8.0	96	6.0	6.3	6.9
EC μ S/cm	250	96	13	22	42
DO %sat	85-120	96	82	94	101
<i>Major Ions mg/L</i>					
Bicarbonate	319	29	<5	8	20
Calcium	-	29	<0.5	0.5	1.3

Analyte	SSTV	Count	Minimum	Median	Maximum
Carbonate	-	29	<1	<5	<10
Chloride mg/L	64	29	1	2	6
Sodium	-	29	0.9	1.5	2.3
Magnesium mg/L	21	29	<0.5	0.6	1.1
Potassium	-	29	<0.01	0.6	2
Sulphate	129	29	<1	1	1
Total Dissolved Solids	-	29	6	10	22
Metals (0.45 µm filtered) µg/L					
Aluminium	150	37	10	50	130
Cadmium	0.8	37	<0.1	0.1	0.2
Chromium	-	37	<1	1	1
Cobalt	13	37	<1	1	1
Copper	2.5	37	<1	1	2
Iron	350	37	33	260	650
Lead	9.4	37	<1	1	1
Manganese	3,600	37	5	8	27
Nickel	17	37	<1	1	12
Zinc	31	37	<1	2	21
Metals total µg/L					
Aluminium	-	37	60	420	2,000
Cadmium	-	37	<0.1	<0.1	<0.2
Copper	-	37	<1	1	2
Iron	-	37	340	1,000	2,300
Nutrients µg/L					
Total Nitrogen	-	29	<0.1	0.2	1.3
Total Phosphorus	-	29	<20	<50	70
Other water quality parameters mg/L					
Hardness (CaCO ₃)	-	29	<3	4.1	7.5
Total Suspended Solids	-	28	<1	<10	13
Cyanide (total)	0.007	12	<0.004	<0.004	<0.004

10.1.7 SW3 Surface Water Quality Results

SW3 is the downstream site in Stow Creek receiving the treated water discharged from Batman Pit before the water enters the Edith River. This site also receives inputs from tributaries including the background site SW13.

A comparison of the median zinc and copper results reported in discharge from Batman Pit and Stow Creek suggests that sufficient dilution of the treated mine water appears to be occurring within Stow Creek in that the SSTVs will be met at the compliance monitoring point SW4 on most occasions. The biological monitoring results also confirms that the discharge of treated mine water through this site on Stow Creek is not adversely impacting on macroinvertebrate populations

10.1.8 SW10 Surface Water Quality Results

SW10 is the downstream site in the Edith River to detect water quality in the receiving environment. Monitoring conducted to date has shown that the water quality at SW4 has not been adversely impacted, and as such further assessment of water quality at SW10 is no longer required.

10.1.9 Conclusion

Based on the 2020/21 water quality data, the water quality in the Edith River has not been adversely impacted by the discharge of treated water from the Mt Todd mine site.

10.2 Groundwater

Vista Gold has groundwater data from 2011 for most of the 16 bores currently monitored on the site on a 6 monthly basis. For ease of interpretation, the bores have been grouped according to their location as shown in **Table 8-5**. Data from the current monitoring bores have been reviewed and a trend analysis conducted on those sites with sufficient data points. A summary of the significant trend analysis is shown in **Table 10-6** and the raw data is shown in this document, Appendix P - Appendix P1. Water levels for each group are shown in **Figure 10-10** to **Figure 10-12**.

Table 10-6 Groundwater trend analysis

Group	Bore	Analyte	Trend	R ²
1	RN028926	Aluminium (total)	Down	0.675161
		Nickel (total)	Down	0.698566
2	MB6S	Barium	Down	0.886528
	SW4MB01	No significant trends		
	WDMB01	No significant trends (≤5 data points and BDL)		
3	BW6P	Calcium	Up	0.70715
		EC	Up	0.858306
		Magnesium	Up	0.738517
		Strontium	Up	0.815972
	MB1	Sulfate	Down	0.829401
	MB3	Ammonia	Down	0.702456
		EC	Up	0.973459
		Magnesium	Up	0.956937
		Sodium	Up	0.810892
		Strontium	Up	0.88638
		Sulfate	Up	0.965307
	MB4	No significant trends (≤5 data points)		
	WDMB02	No significant trends (≤5 data points)		
	4	MB5	Sulfate	Down
TDMB1D		Chloride	Down	0.893126
		Cadmium	Down	0.680027
TDMB2D		Iron	Down	0.702833
TDMB2S		No significant trends		
TDMB3D		Ammonia	Up	0.772519
		Cobalt	Up	0.906437
TDMB4D		No significant trends		
TDMB1		Nitrite	Down	0.738269
	Strontium	Down	0.767769	
5	TSF2MB02	No significant trends		
	TSF2MB01	No significant trends (≤5 data points)		

Notes:

1. Analytes with ≤5 data points were not included in the table above (this includes analytes where the majority of data was below detection limits (BDL)).
2. Historical data detection limits were higher than recent data and even though all data was below detection limits Esdat derive a significant trend. These data were reviewed and not recorded in Table 10-5

Figure 10-1 to Figure 10-9 show the analytes shown to be of potential concern as identified in the trend analysis shown in **Table 10-6**.

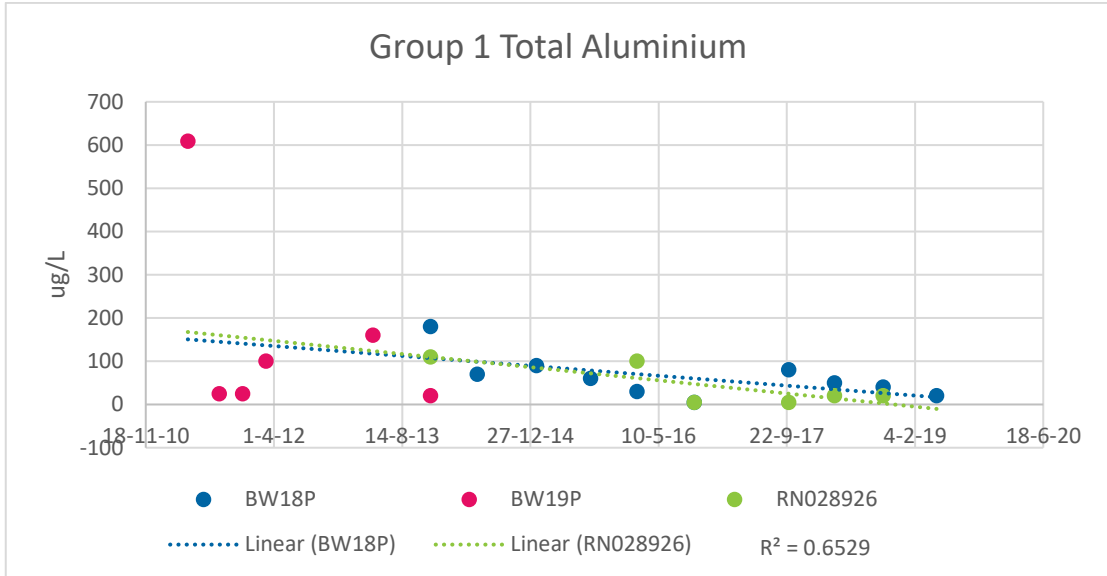

Figure 10-1 Total aluminium Group 1

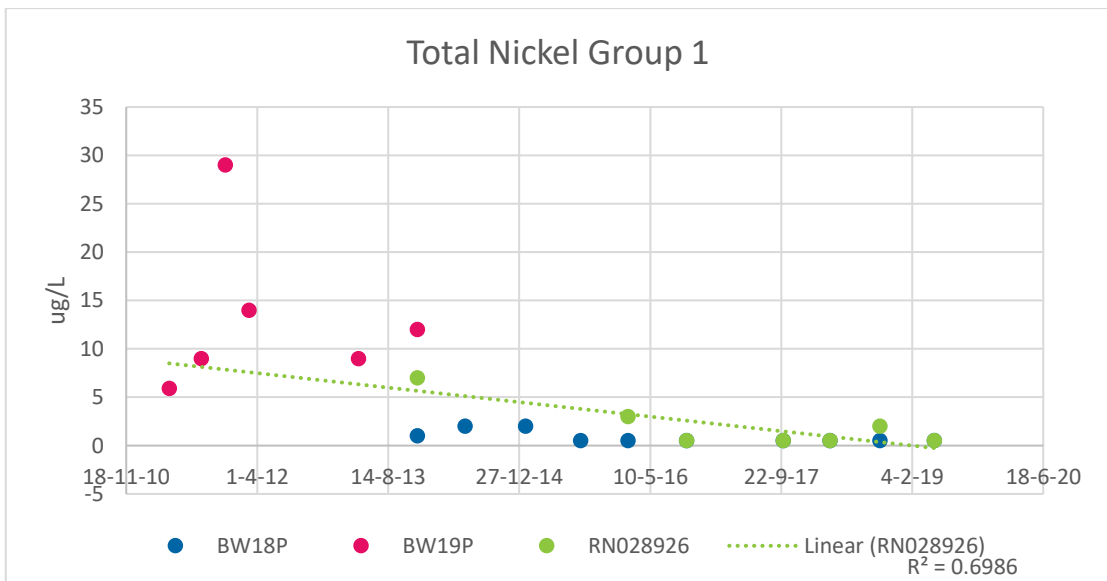

Figure 10-2 Group 1 Total nickel

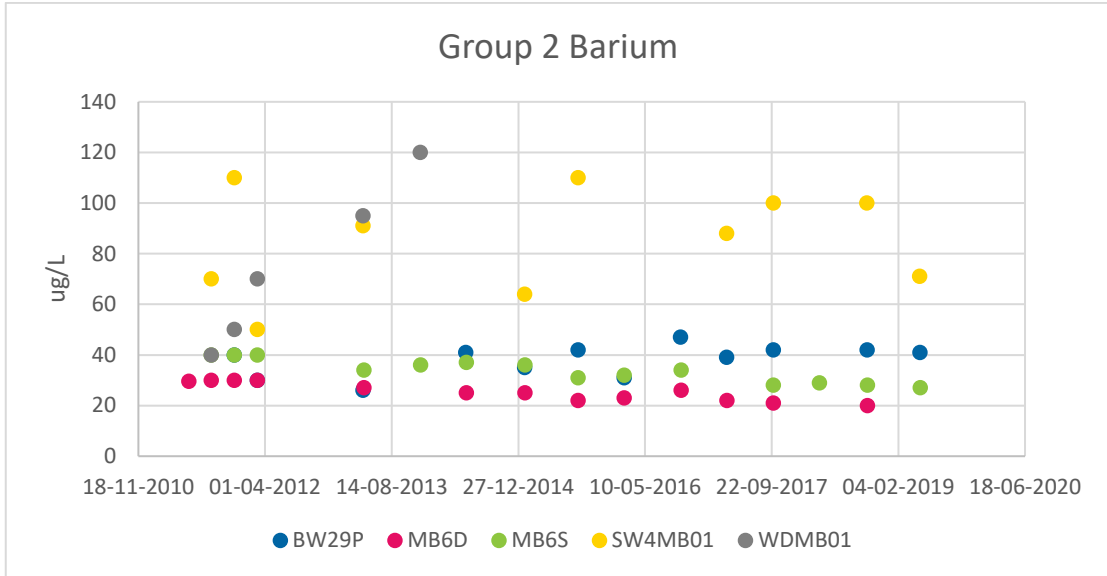

Figure 10-3 Group 2 Barium

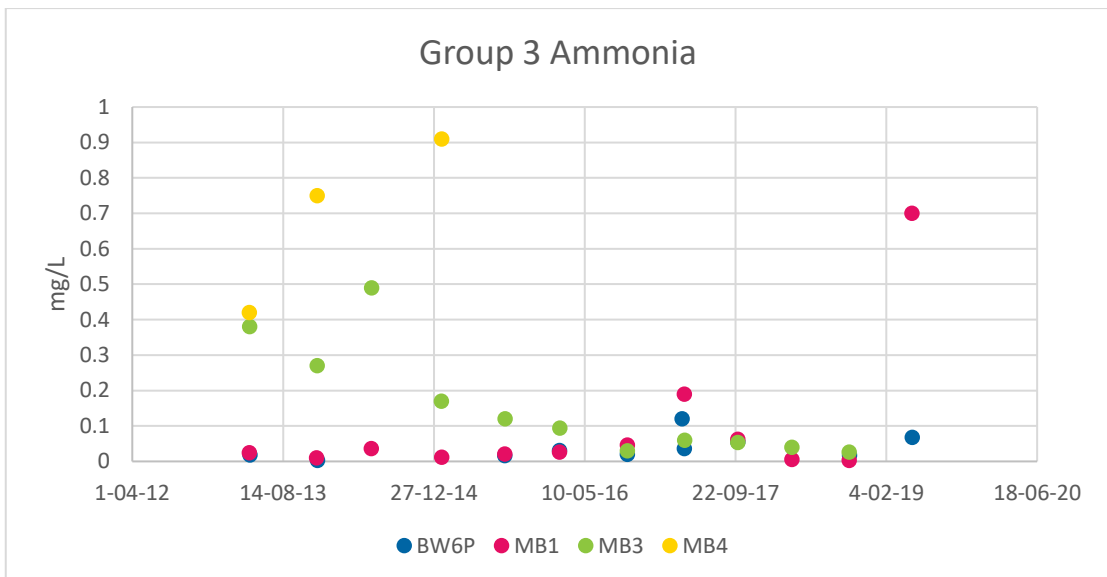

Figure 10-4 Group 3 Ammonia

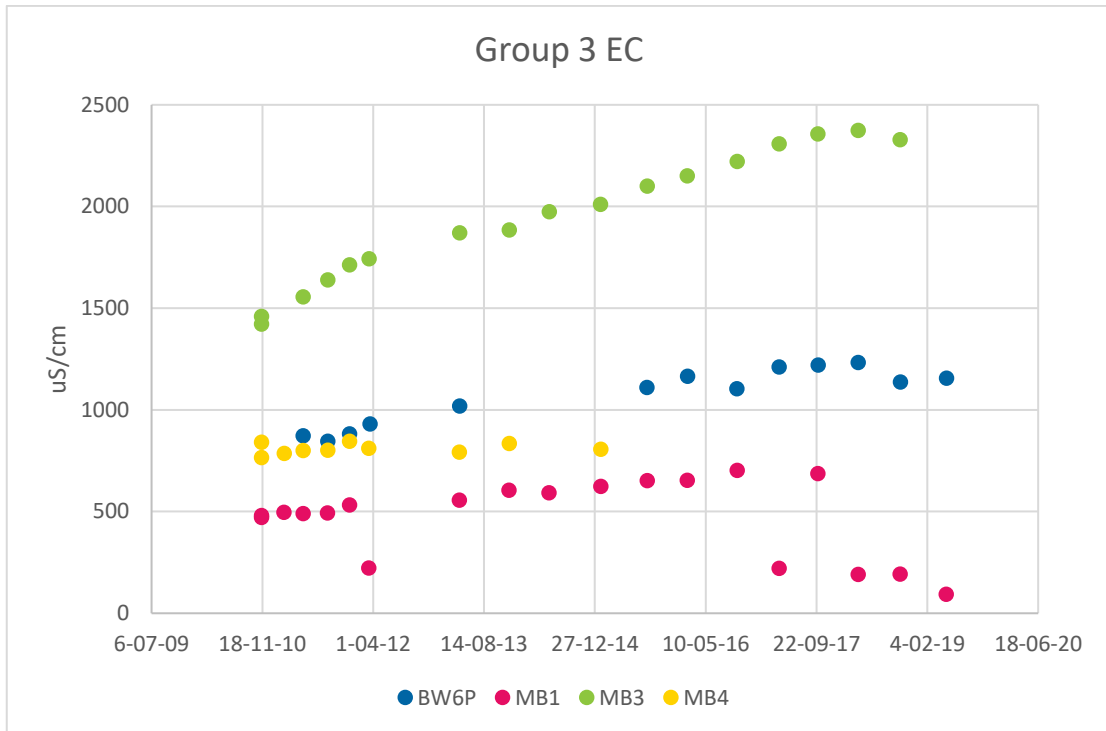

Figure 10-5 Group 3 EC

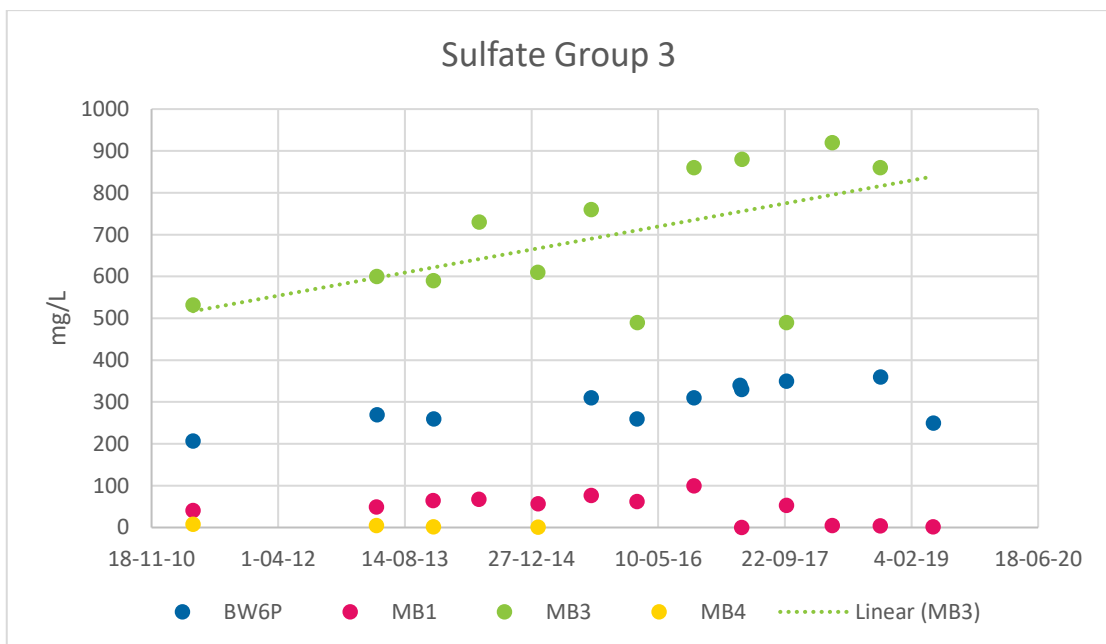

Figure 10-6 Group 3 Sulfate

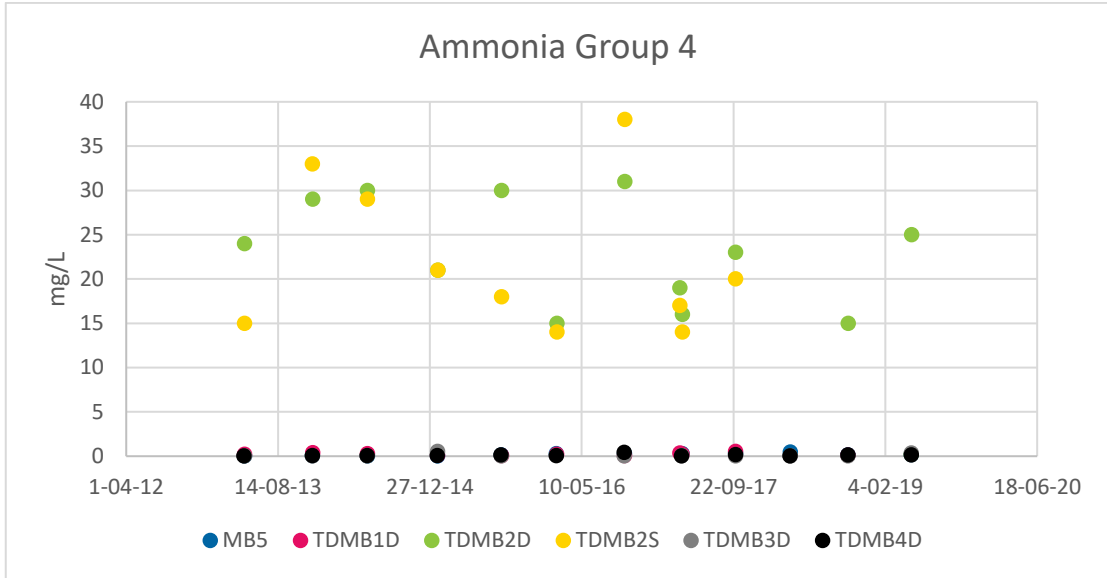

Figure 10-7 Group 4 Ammonia

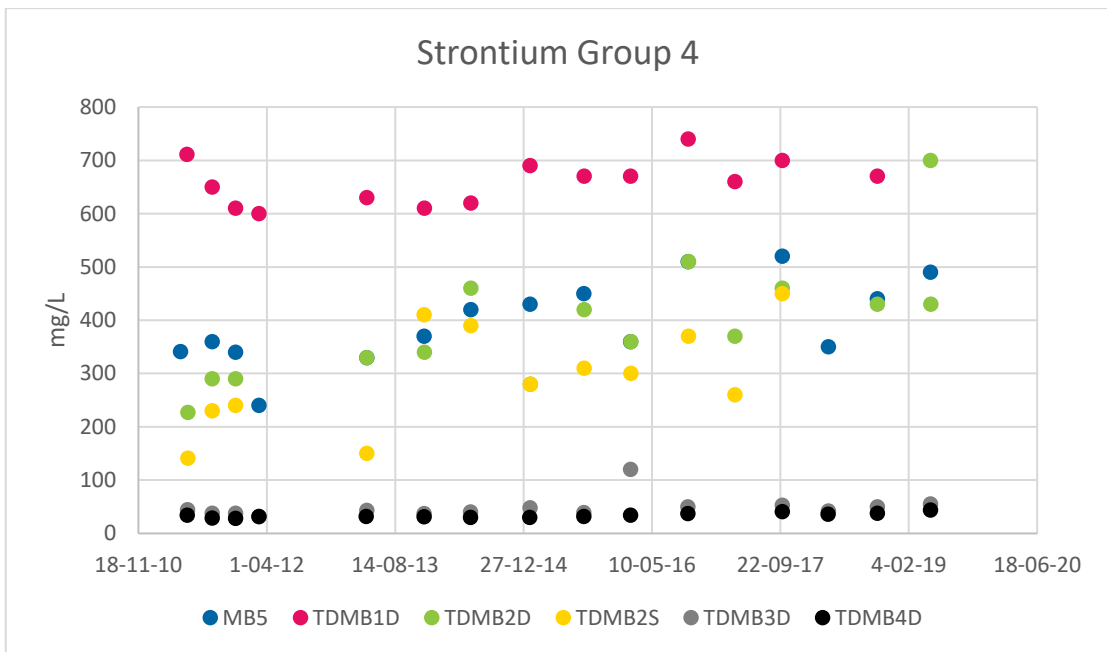

Figure 10-8 Group 4 Strontium

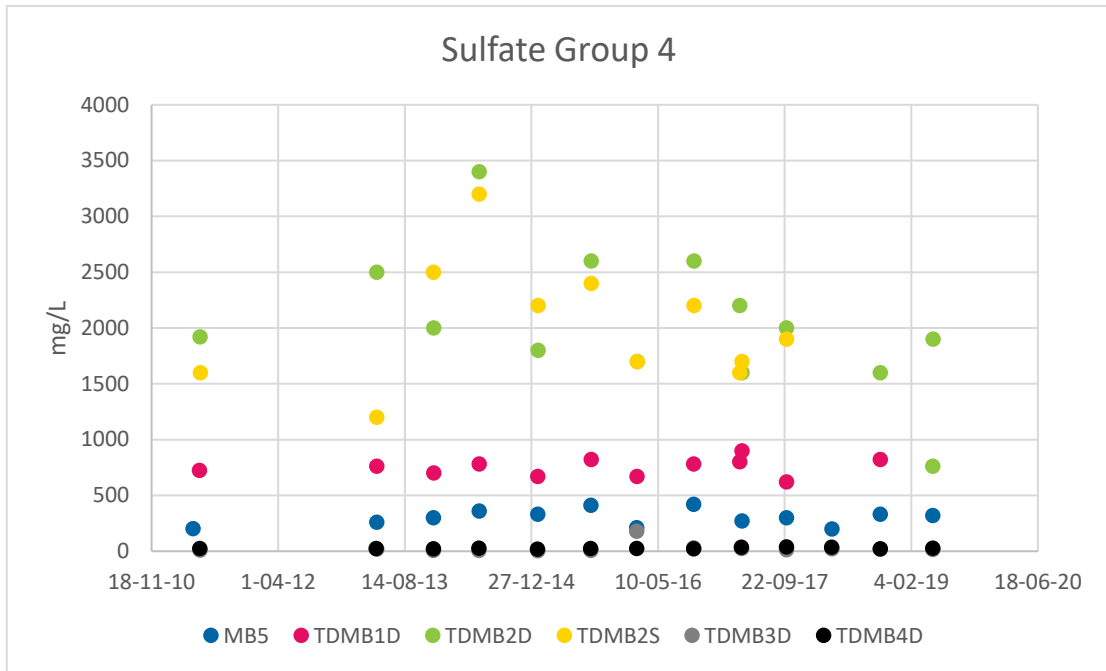

Figure 10-9 Group 4 Sulfate

Groundwater levels for Groups 1 - 3 are shown in **Figures 10-11 to Figure 10-13**.

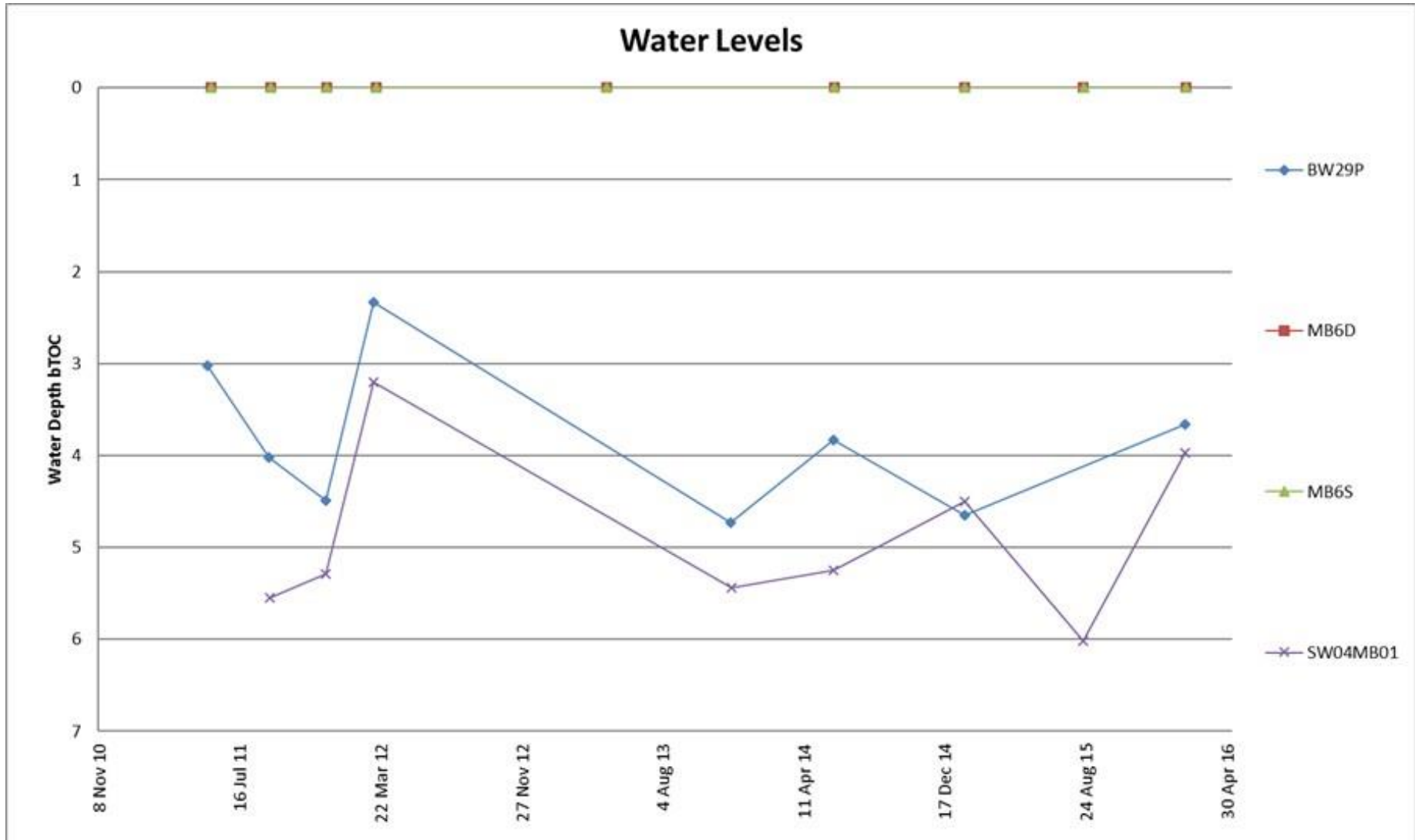

Figure 10-10 Group 1 Water Levels

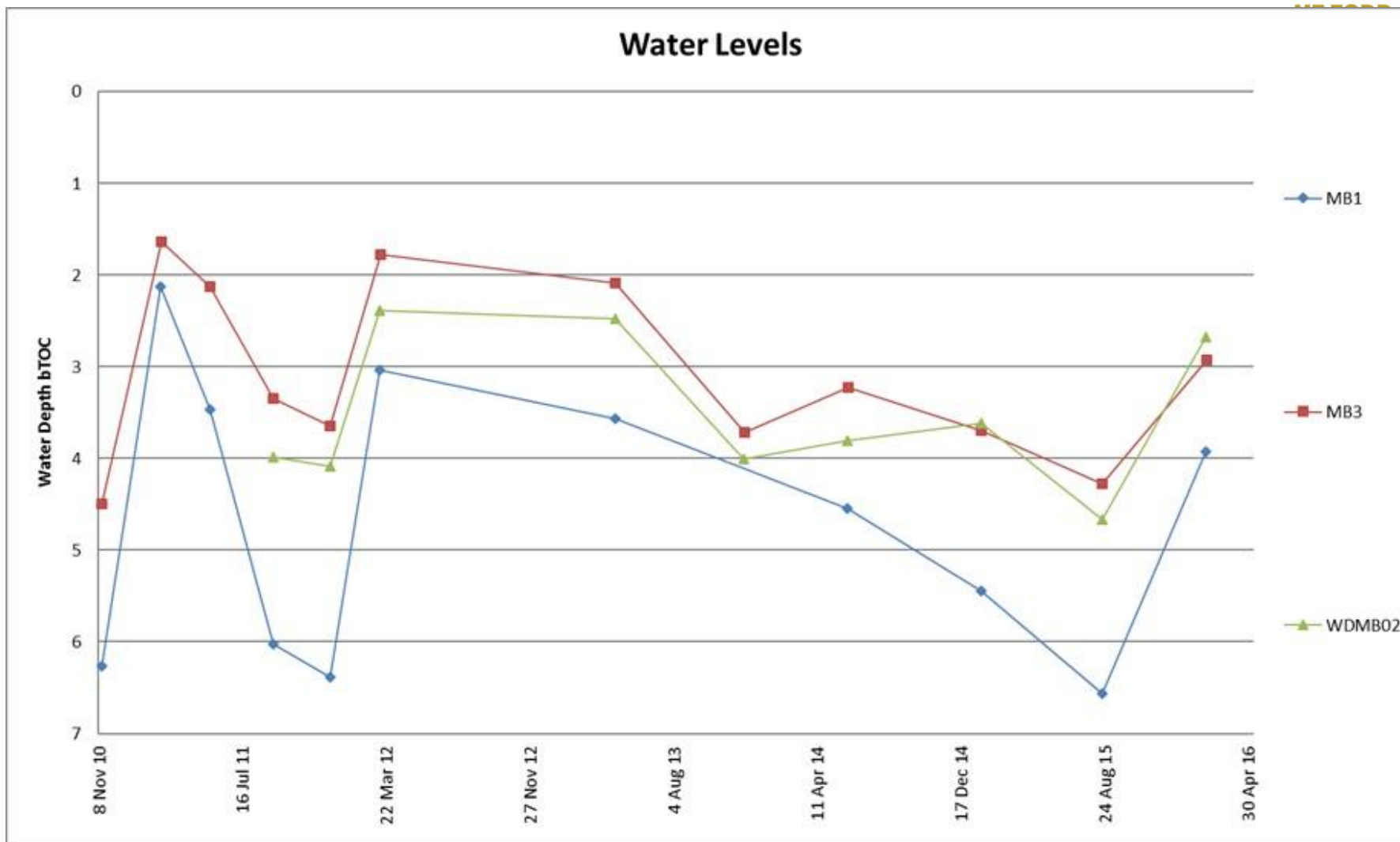

Figure 10-11 Group 2 Water Levels

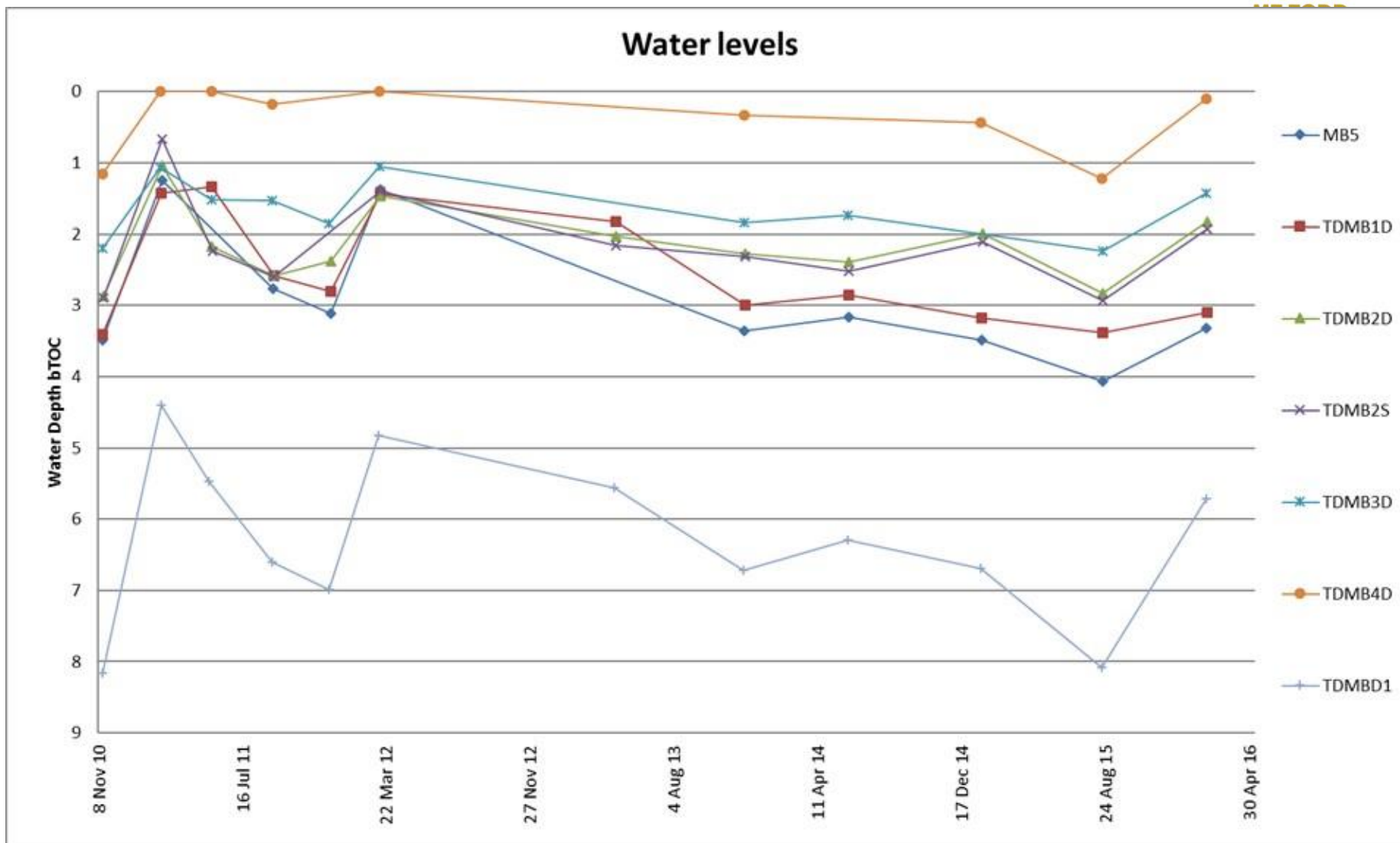

Figure 10-12 Group 3 Water Levels

10.3 Macroinvertebrate Monitoring

Macroinvertebrate monitoring was conducted in conjunction with the sediment monitoring program. The results of the macroinvertebrate monitoring program are located in the annual report, which can be found at <http://www.mttodd.com.au/waste-discharge-licence.html>. The monitoring programme has a new monitoring site (SCUP) located on Stow Creek upstream of STCOP as STCOP will be covered by TSF2. A summary of the results is provided below.

Overall, there were no significant differences between macroinvertebrate metrics or community composition close to the authorised discharge point of treated mine water from Batman Pit on Stow Creek (SCBTM) and the Stow Creek upstream site (SCTOP). However, macroinvertebrate assemblages on the Edith River downstream of the Stow Creek confluence (ERSW4), and therefore downstream of the mine discharge, were significantly different in composition to the Edith River upstream (ERUS and ERTOP). These differences were shown in most metrics used when assessing macroinvertebrate results. However, these differences are related to the creek flow and timing of sampling and not to a point source discharge.

Previous BMPs associated with the MTPA operations have not reported the differences noted during the 2021 monitoring program for macroinvertebrate metrics between upstream and downstream sites in Edith River. Previous BMPs did not show any discernible differences between the macroinvertebrate assemblages recorded between upstream and downstream sampling sites.

Operations within the MTPA have not changed in the lead up to the 2021 BMP and the SIGNAL-2 results were not significantly different between the sites, indicating that point source pollution was unlikely to be the cause of the differences noted within Edith River. However, during the surface water monitoring program it was observed that Edith River did not flow between June and early December 2020, which is uncommon for this river system. Only ponds of water were noted within Edith River (ERUS, ERSW4 and ERDS) during this period. The low flows noted in Edith River could be correlated to the lower-than-average rainfall experienced in the years preceding 2021. Nevertheless, above average rainfall was experienced within the region just prior to the 2021 sampling event (December 2020, February and March 2021). This, SIGNAL-2 results and community composition analyses suggests that habitat characteristics of the sample sites at the time of the 2021 monitoring program is a likely contributing factor to the differences in macroinvertebrate assemblages noted between the upstream and downstream sites on Edith River.

Notwithstanding the above, it was also noted that shallow sites (e.g., ERSW4, ERUS) were characterised by flow, riffles and broken water whereas deeper pool sites (e.g., ERDS, SCDS), water was turbid and flowing. These conditions suggest that the 2021 sampling event may have been completed earlier than recommended by the NT Darwin-Daly AusRivas Sampling Protocols, which states that sampling should take place 4-6 weeks after a flushing event occurs within the catchment. Prior to the 2021 sampling event, almost 140 mm of rain was recorded at the closest available weather station in March 2021, which was preceded by almost double the average rainfall being recorded in February 2021. These conditions would have resulted in high flows and flushing in the Edith River catchment. Additionally, flows of this magnitude would have likely been followed by declining, although not stable flows, which were still present during sampling in mid-April 2021.

In conclusion, macroinvertebrate metrics were significantly different for sites on Edith River that are upstream and downstream of the Stow Creek confluence. The SIGNAL-2 results were not

significantly different between the sites, indicating that point source pollution was unlikely to be the cause of the differences noted. Therefore, timing of the sampling of the sites prior to stabilising water flow and macroinvertebrate populations in the catchment likely resulted in the observed differences between the Edith River upstream sites and the downstream sites.

10.3.1 Fish tissue study

Contributions to fish tissue surveys were included as recommendations within the NT EPA assessment report for the project (see recommendation 26). During the EIS a commitment to NT Fisheries was made by Vista Gold to contribute to any future fish tissue monitoring program. There has not been a program developed for the Edith and Daly Rivers since the EIS, however Vista Gold remains committed to contributing in the future.

Current and predicted water quality in the Edith River does not indicate that metals will bioaccumulate to detrimental levels in fish species downstream of the Mt Todd site.

10.4 Sediment Monitoring

As discussed in **Section 10.3**, the sediment monitoring was conducted in conjunction with the macroinvertebrate monitoring program. The results of the sediment monitoring program are located at <http://www.mttodd.com.au/waste-discharge-licence.html>. A summary of the results is shown below.

Analytical results shows that sediment contaminant concentrations are below nominated guideline values for both reference and receiving sampling sites. Comparison of the analytical results obtained for reference and receiving sites shows that lower heavy metals concentrations were reported at the receiving sites when compared to the reference sites.

Generally, the receiving sites showed an overall reduction in bioavailable metal concentrations since discharging of treated mine water from Batman Pit commenced in 2013.

The surface water runoff from the normal wet season in 2020/21 contributed to elevated aluminium, iron and manganese observed in the upstream sites.

The PSD results were found to be variable across all sites sampled. Receiving sites recorded non-negligible silt/clay proportions when compared to reference sites, which indicates that no substantial sediment smothering, or build-up of metals has occurred in the catchment as a result of controlled discharges from the MTPA.

In conclusion, results of the 2021 sediment monitoring program shows that discharge from the MTPA has not had a measurable impact on the sediment quality within the receiving waterways. All receiving sites showed similarity to reference sites with respect to sediment quality.



Appendix P1

Groundwater Data

Mt Todd Groundwater Trend Analysis 2011 -2019

Trend Analysis using Linear Regression with Significance = 0.05

Location_Code	ChemName	Total_or_Filtered	Linear Trend	R2	t-test alpha
MB6S	Alkalinity (Bicarbonate as CaCO3)	T	No Trend	5.13E-02	0.83813
MB6S	Alkalinity (Bicarbonate)	T	No Trend	0.049499	0.822802
MB6S	Alkalinity (Carbonate as CaCO3)	T	No Change	0	0
MB6S	Alkalinity (Carbonate)	T	Down	0.567077	4.282329
MB6S	Alkalinity (Hydroxide)	T	No Change	0	0
MB6S	Alkalinity (Hydroxide) as CaCO3	T	No Change	0	0
MB6S	Alkalinity (total)	T	No Trend	0.274871	0.870708
MB6S	Alkalinity (total) as CaCO3	T	No Trend	0.116686	0.890282
MB6S	Aluminium	F	Down	0.522383	3.62281
MB6S	Aluminium	T	Down	0.576541	4.042031
MB6S	Ammonia as N	F	No Trend	6.10E-02	0.805799
MB6S	Ammonia as N	T	No Trend	0.272727	0.866025
MB6S	Anions Total	T	No Trend		
MB6S	Antimony	F	Down	0.522383	3.62281
MB6S	Arsenic	F	No Trend	0.147339	1.439995
MB6S	Arsenic	T	Down	0.412384	2.901984
MB6S	Barium	F	Down	0.886528	9.682629
MB6S	Beryllium	F	Down	0.522383	3.62281
MB6S	Bismuth	F	Down	0.522383	3.62281
MB6S	Boron	F	No Trend	9.17E-03	0.333332
MB6S	Cadmium	F	Down	0.522383	3.62281
MB6S	Cadmium	T	Down	0.522383	3.62281
MB6S	Calcium	F	No Trend	1.73E-02	0.419717
MB6S	Calcium	T	Up	0.338836	2.58114
MB6S	Carbonate Alkalinity as CaCO3_	T	Down	0.992953	16.78757
MB6S	Cations Total	T	No Trend		
MB6S	Chloride	T	No Trend	0.129905	1.393163
MB6S	Chromium (III+VI)	F	No Change	0	0
MB6S	Cobalt	F	Down	0.345414	2.516384
MB6S	Cobalt	T	Down	0.296783	2.250431
MB6S	Copper	F	No Trend	0.169416	1.5645
MB6S	Copper	T	No Trend	0.126803	1.320075
MB6S	Cyanide (amenable)	T	Up	0.482425	3.612373
MB6S	Cyanide (Free)	T	Down	0.482425	3.612373
MB6S	Cyanide Total	T	Down	0.482425	3.612373
MB6S	DO (Field)	T	No Trend	0.4476	1.800315
MB6S	EC (field)	T	No Trend	4.08E-03	0.239374
MB6S	Hardness as CaCO3	T	No Trend		
MB6S	Hydroxide as CaCO3	T	No Trend		
MB6S	Ionic Balance	T	Up	0.318681	2.051746
MB6S	Iron	F	Down	0.302787	2.282845
MB6S	Iron	T	Down	0.564168	3.941265
MB6S	Kjeldahl Nitrogen Total	F	No Trend	0.163162	1.396334
MB6S	Kjeldahl Nitrogen Total	T	No Change	0	0
MB6S	Lead	F	No Change	0	0
MB6S	Lead	T	No Change	0	0
MB6S	Lithium	F	Up	0.316042	2.354766
MB6S	Magnesium	F	No Trend	6.75E-02	0.850827
MB6S	Magnesium	T	No Trend	1.26E-02	0.407954
MB6S	Manganese	F	No Trend	0.126948	1.32094
MB6S	Manganese	T	Down	0.505526	3.5026
MB6S	Mercury	F	No Change	0	0
MB6S	Mercury	T	No Trend	4.90E-14	7.00E-07
MB6S	Molybdenum	F	Down	0.522383	3.62281

Mt Todd Groundwater Trend Analysis 2011 -2019

MB6S	Nickel	F	No Trend	3.16E-02	0.626019
MB6S	Nickel	T	No Trend	0.145963	1.432099
MB6S	Nitrate (as N)	F	No Trend	0.13864	1.60477
MB6S	Nitrite (as N)	F	No Trend	0.173649	0.648289
MB6S	Nitrite (as N)	T	No Trend	1.54E-13	1.18E-06
MB6S	Nitrogen (Total)	T	No Trend	4.23E-02	0.75778
MB6S	pH (Field)	T	Down	0.195829	1.846412
MB6S	Phosphate total (as P)	T	No Trend	0.75	1.732051
MB6S	Phosphorus	T	No Change	0	0
MB6S	Potassium	F	No Trend	2.76E-04	5.26E-02
MB6S	Potassium	T	No Trend	0.16572	1.606951
MB6S	Selenium	F	No Change	0	0
MB6S	Silver	F	Down	0.522383	3.62281
MB6S	Sodium	F	No Trend	0.125998	1.200676
MB6S	Sodium	T	No Trend	2.64E-02	0.593317
MB6S	Strontium	F	Up	0.50842	3.52294
MB6S	Sulphate	T	Down	0.43283	2.762501
MB6S	Sulphate as S	T	No Trend	3.03E-02	0.25
MB6S	TDS	F	No Trend	0.112434	1.378461
MB6S	Temp (Field)	T	Up	0.291716	2.401268
MB6S	Thallium	F	No Change	0	0
MB6S	Thiocyanates (total)	T	No Trend		
MB6S	Thiocyanic Acid	T	No Trend	8.75E-03	0.325465
MB6S	Thorium	F	Down	0.298277	2.258489
MB6S	Tin	F	Down	0.522383	3.62281
MB6S	Titanium	F	Down	0.522383	3.62281
MB6S	Uranium	F	Down	0.498992	3.457124
MB6S	Vanadium	F	Down	0.522383	3.62281
MB6S	Weak Acid Dissociable Cyanide	T	Down	0.482425	3.612373
MB6S	Zinc	F	Down	0.437899	3.057531
MB6S	Zinc	T	Down	0.21159	1.794579
MB7D	Alkalinity (Bicarbonate as CaCO3)	T	No Trend	1.65E-02	0.224107
MB7D	Alkalinity (Bicarbonate)	T	Up	0.348501	1.93506
MB7D	Alkalinity (Carbonate as CaCO3)	T	No Change	0	0
MB7D	Alkalinity (Carbonate)	T	No Trend	0.151737	1.196261
MB7D	Alkalinity (Hydroxide)	T	No Change	0	0
MB7D	Alkalinity (total)	T	No Trend	8.51E-02	0.681966
MB7D	Aluminium	F	No Trend	8.78E-03	0.230483
MB7D	Aluminium	T	No Trend	7.76E-02	0.710452
MB7D	Ammonia as N	F	No Trend	7.69E-02	0.288675
MB7D	Ammonia as N	T	No Trend	1.67E-02	0.225597
MB7D	Anions Total	T	No Trend	0.242269	0.565446
MB7D	Antimony	F	No Trend	6.54E-02	0.528938
MB7D	Arsenic	F	No Trend	0.286182	1.550969
MB7D	Arsenic	T	No Trend	0.11763	0.894355
MB7D	Barium	F	Down	0.834936	4.498122
MB7D	Beryllium	F	No Trend	0.399579	1.631561
MB7D	Bismuth	F	No Trend	3.50E-02	0.380776
MB7D	Boron	F	No Trend	0.498207	1.992843
MB7D	Cadmium	F	Down	0.895344	7.164539
MB7D	Cadmium	T	Down	0.895344	7.164539
MB7D	Calcium	F	Down	0.883386	5.504645
MB7D	Calcium	T	No Trend	0.105147	0.685572
MB7D	Carbonate Alkalinity as CaCO3_	T	No Trend		
MB7D	Cations Total	T	No Trend	0.898345	2.97274
MB7D	Chloride	T	No Trend	0.272461	1.619097

Mt Todd Groundwater Trend Analysis 2011 -2019

MB7D	Chromium (III+VI)	F	No Change	0	0
MB7D	Cobalt	F	No Trend	0.379304	1.914829
MB7D	Cobalt	T	No Trend	0.339139	1.754725
MB7D	Copper	F	No Trend	1.67E-02	0.319046
MB7D	Copper	T	No Trend	5.24E-02	0.57621
MB7D	Cyanide (amenable)	T	No Trend	0.17991	1.047327
MB7D	Cyanide (Free)	T	No Trend	0.413821	1.87878
MB7D	Cyanide Total	T	Down	0.568838	2.56838
MB7D	EC (field)	T	Up	0.449946	2.215404
MB7D	Hydroxide	T	No Change	0	0
MB7D	Ionic Balance	T	Down	0.725608	2.816605
MB7D	Iron	F	Down	0.897823	7.260965
MB7D	Iron	T	No Trend	0.14901	1.024994
MB7D	Kjeldahl Nitrogen Total	F	No Trend	0.75	1.732051
MB7D	Kjeldahl Nitrogen Total	T	Up	0.752162	3.0174
MB7D	Lead	F	No Trend	0.267136	1.478872
MB7D	Lead	T	No Trend	0.280501	1.529422
MB7D	Lithium	F	No Trend	3.34E-02	0.371641
MB7D	Magnesium	F	No Trend	0.512704	2.051479
MB7D	Magnesium	T	No Trend	1.58E-05	7.96E-03
MB7D	Manganese	F	Down	0.822254	5.268402
MB7D	Manganese	T	No Trend	5.84E-02	0.610188
MB7D	Mercury	F	No Trend		
MB7D	Mercury	T	Down	0.96224	8.74354
MB7D	Molybdenum	F	No Trend	6.54E-02	0.528938
MB7D	Nickel	F	No Trend	2.63E-02	0.402887
MB7D	Nickel	T	No Trend	0.108834	0.856009
MB7D	Nitrate (as N)	F	No Trend	1.49E-02	0.275426
MB7D	Nitrate (as N)	T	No Trend		
MB7D	Nitrite (as N)	F	No Trend		
MB7D	Nitrite (as N)	T	No Change	0	0
MB7D	Nitrogen (Total)	T	Up	0.478613	2.142384
MB7D	pH (Field)	T	No Trend	0.437948	1.973822
MB7D	Phosphate total (as P)	T	No Trend		
MB7D	Phosphorus	T	Up	0.962772	7.191893
MB7D	Potassium	F	No Trend	0.281362	1.251432
MB7D	Potassium	T	Up	0.569663	2.301097
MB7D	Selenium	F	No Trend	0.382276	1.573336
MB7D	Silver	F	No Trend	6.54E-02	0.528938
MB7D	Sodium	F	Up	0.557589	2.245298
MB7D	Sodium	T	No Trend	0.527919	2.114975
MB7D	Strontium	F	Down	0.737287	3.350486
MB7D	Sulphate	F	Down	0.939327	5.564483
MB7D	Sulphate	T	Down	0.904212	5.321585
MB7D	Sulphate as S	T	Down	1	999
MB7D	TDS	F	No Trend	0.106512	0.59802
MB7D	TDS	T	No Trend		
MB7D	Temp (Field)	T	No Trend	0.12703	0.852978
MB7D	Thallium	F	No Trend	0.382276	1.573336
MB7D	Thiocyanates (total)	T	No Trend		
MB7D	Thiocyanic Acid	T	Down	1	4534797
MB7D	Thiosulphate	T	No Trend		
MB7D	Thorium	F	No Trend	2.75E-02	0.336564
MB7D	Tin	F	No Trend	0.122745	0.748118
MB7D	Titanium	F	Down	0.57439	2.323419
MB7D	Uranium	F	No Trend	7.90E-02	0.585741

Mt Todd Groundwater Trend Analysis 2011 -2019

MB7D	Vanadium	F	No Trend	6.54E-02	0.528938
MB7D	Weak Acid Dissociable Cyanide	T	Down	0.568838	2.56838
MB7D	Zinc	F	Down	0.413231	2.055601
MB7D	Zinc	T	No Trend	8.42E-03	0.22573
MB7S	Alkalinity (Bicarbonate as CaCO3)	T	No Trend	0.299986	0.925789
MB7S	Alkalinity (Bicarbonate)	T	No Trend	0.324139	1.548539
MB7S	Alkalinity (Carbonate as CaCO3)	T	No Trend		
MB7S	Alkalinity (Carbonate)	T	No Trend	0.137456	0.977839
MB7S	Alkalinity (Hydroxide)	T	No Trend		
MB7S	Alkalinity (total)	T	No Trend	0.590853	1.699477
MB7S	Aluminium	F	No Trend	9.22E-04	6.79E-02
MB7S	Aluminium	T	No Trend	6.62E-03	0.182606
MB7S	Ammonia as N	F	No Trend		
MB7S	Ammonia as N	T	No Trend	0.181538	0.941923
MB7S	Anions Total	T	No Trend	0.242106	0.565196
MB7S	Antimony	F	No Trend	6.98E-04	5.29E-02
MB7S	Arsenic	F	Down	0.541697	2.431012
MB7S	Arsenic	T	No Trend	0.336983	1.594142
MB7S	Barium	F	No Trend	1.25E-02	0.224775
MB7S	Beryllium	F	No Trend	1.02E-02	0.203327
MB7S	Bismuth	F	No Trend	6.35E-04	5.04E-02
MB7S	Boron	F	No Trend	0.359111	1.497106
MB7S	Cadmium	F	Down	0.781721	4.231604
MB7S	Cadmium	T	Down	0.781721	4.231604
MB7S	Calcium	F	Up	0.98679	12.22273
MB7S	Calcium	T	Up	0.909006	6.3213
MB7S	Carbonate Alkalinity as CaCO3_	T	No Change	0	0
MB7S	Cations Total	T	No Trend	0.242106	0.565196
MB7S	Chloride	T	No Trend	0.290012	1.429117
MB7S	Chromium (III+VI)	F	No Change	0	0
MB7S	Cobalt	F	No Trend	1.17E-03	7.64E-02
MB7S	Cobalt	T	No Trend	0.188856	1.07895
MB7S	Copper	F	No Trend	3.92E-04	4.43E-02
MB7S	Copper	T	Up	0.470002	2.105707
MB7S	Cyanide (amenable)	T	No Trend	8.20E-02	0.668286
MB7S	Cyanide (Free)	T	No Trend	0.394991	1.80675
MB7S	Cyanide Total	T	Down	0.479875	2.147809
MB7S	EC (field)	T	Up	0.781874	3.78656
MB7S	Hydroxide	T	No Change	0	0
MB7S	Ionic Balance	T	Down	0.978809	9.611347
MB7S	Iron	F	No Trend	4.22E-03	0.145527
MB7S	Iron	T	No Trend	0.082814	0.671904
MB7S	Kjeldahl Nitrogen Total	F	No Trend		
MB7S	Kjeldahl Nitrogen Total	T	Up	0.588241	2.672642
MB7S	Lead	F	No Trend	0.298891	1.459984
MB7S	Lead	T	Up	0.689551	3.332523
MB7S	Lithium	F	Down	0.597061	2.434557
MB7S	Magnesium	F	Up	0.942682	5.735228
MB7S	Magnesium	T	Up	0.667947	2.836594
MB7S	Manganese	F	No Trend	2.79E-04	0.037376
MB7S	Manganese	T	No Trend	0.226165	1.208854
MB7S	Mercury	F	No Change	0	0
MB7S	Mercury	T	Down	0.999998	803.0942
MB7S	Molybdenum	F	No Trend	6.98E-04	5.29E-02
MB7S	Nickel	F	No Trend	5.17E-02	0.522217
MB7S	Nickel	T	Up	0.678445	3.247993

Mt Todd Groundwater Trend Analysis 2011 -2019

MB7S	Nitrate (as N)	F	No Trend	0.187574	1.176984
MB7S	Nitrate (as N)	T	No Trend		
MB7S	Nitrite (as N)	F	No Trend	0.75	1.732051
MB7S	Nitrite (as N)	T	No Change	0	0
MB7S	Nitrogen (Total)	T	No Trend	8.34E-02	0.603314
MB7S	pH (Field)	T	No Trend	0.344409	1.449609
MB7S	Phosphate total (as P)	T	No Trend	1.69E-27	4.11E-14
MB7S	Phosphorus	T	Up	0.999998	803.0942
MB7S	Potassium	F	Up	0.960311	6.956399
MB7S	Potassium	T	Up	0.802178	4.027432
MB7S	Selenium	F	No Trend	0.26046	1.186915
MB7S	Silver	F	No Trend	6.98E-04	5.29E-02
MB7S	Sodium	F	Down	0.85824	3.479703
MB7S	Sodium	T	Down	0.707932	3.113751
MB7S	Strontium	F	Up	0.908645	6.307538
MB7S	Sulphate	F	No Trend	0.757894	1.769299
MB7S	Sulphate	T	Up	0.99634	16.49917
MB7S	Sulphate as S	T	No Change	0	0
MB7S	TDS	F	Up	0.906032	5.378273
MB7S	TDS	T	No Trend		
MB7S	Temp (Field)	T	No Trend	4.53E-02	0.435826
MB7S	Thallium	F	No Trend	0.377689	1.558095
MB7S	Thiocyanates (total)	T	No Trend		
MB7S	Thiocyanic Acid	T	No Trend		
MB7S	Thiosulphate	T	No Trend		
MB7S	Thorium	F	No Trend	3.93E-03	0.125586
MB7S	Tin	F	No Trend	1.02E-02	0.203327
MB7S	Titanium	F	Down	0.553024	2.224639
MB7S	Uranium	F	No Trend	6.24E-02	0.515796
MB7S	Vanadium	F	No Trend	0.19178	0.974243
MB7S	Weak Acid Dissociable Cyanide	T	No Trend	0.418707	1.897767
MB7S	Zinc	F	No Trend	1.31E-02	0.257476
MB7S	Zinc	T	No Trend	4.34E-03	0.147612
RN028926	Alkalinity (Bicarbonate as CaCO3)	T	No Trend	0.273098	1.501401
RN028926	Alkalinity (Bicarbonate)	T	No Trend	0.273098	1.501401
RN028926	Alkalinity (Carbonate as CaCO3)	T	No Change	0	0
RN028926	Alkalinity (Carbonate)	T	No Change	0	0
RN028926	Alkalinity (Hydroxide)	T	No Trend		
RN028926	Alkalinity (Hydroxide) as CaCO3	T	No Change	0	0
RN028926	Alkalinity (total)	T	No Trend		
RN028926	Alkalinity (total) as CaCO3	T	Up	0.579253	2.623664
RN028926	Aluminium	F	No Change	0	0
RN028926	Aluminium	T	Down	0.675161	3.223697
RN028926	Ammonia as N	F	No Trend	0.282513	1.537049
RN028926	Anions Total	T	No Trend		
RN028926	Antimony	F	No Change	0	0
RN028926	Arsenic	F	No Trend	0.299856	1.46335
RN028926	Arsenic	T	No Trend	6.03E-02	0.566667
RN028926	Barium	F	No Trend	9.85E-02	0.739095
RN028926	Beryllium	F	No Change	0	0
RN028926	Bismuth	F	No Change	0	0
RN028926	Boron	F	No Trend	0.256895	1.314734
RN028926	Cadmium	F	No Trend	3.20E-14	4.00E-07
RN028926	Cadmium	T	No Trend	3.20E-14	4.00E-07
RN028926	Calcium	F	No Trend	0.213066	1.274569
RN028926	Calcium	T	No Trend	2.51E-02	0.359026

Mt Todd Groundwater Trend Analysis 2011 -2019

RN028926	Carbonate Alkalinity as CaCO3_	T	No Trend		
RN028926	Cations Total	T	No Trend		
RN028926	Chloride	T	No Trend	6.03E-03	0.190733
RN028926	Chromium (III+VI)	F	No Change	0	0
RN028926	Cobalt	F	No Trend	0.366151	1.699504
RN028926	Cobalt	T	Down	0.578761	2.621022
RN028926	Copper	F	No Change	0	0
RN028926	Copper	T	No Trend	0.12026	0.826741
RN028926	Cyanide (amenable)	T	No Trend	2.58E-14	3.94E-07
RN028926	Cyanide (Free)	T	No Change	0	0
RN028926	Cyanide Total	T	No Change	0	0
RN028926	DO (Field)	T	No Trend	6.34E-02	0.52042
RN028926	EC (field)	T	No Trend	1.82E-02	0.304784
RN028926	Hardness as CaCO3	T	No Trend		
RN028926	Hydroxide as CaCO3	T	No Trend		
RN028926	Ionic Balance	T	No Trend	4.36E-02	0.477321
RN028926	Iron	F	Up	0.462221	2.073042
RN028926	Iron	T	No Trend	0.14542	0.922403
RN028926	Kjeldahl Nitrogen Total	F	Down	0.391662	1.965434
RN028926	Lead	F	No Change	0	0
RN028926	Lead	T	No Trend	8.19E-03	0.20316
RN028926	Lithium	F	No Trend	2.08E-02	0.326036
RN028926	Magnesium	F	No Trend	0.106385	0.845165
RN028926	Magnesium	T	No Trend	3.66E-02	0.435934
RN028926	Manganese	F	No Trend	0.192977	1.09344
RN028926	Manganese	T	No Trend	0.016643	0.290904
RN028926	Mercury	T	No Trend	1.12E-13	8.19E-07
RN028926	Molybdenum	F	No Change	0	0
RN028926	Nickel	F	No Trend	6.91E-03	0.186578
RN028926	Nickel	T	Down	0.698566	3.404024
RN028926	Nitrate (as N)	F	No Trend	5.98E-13	1.89E-06
RN028926	Nitrite (as N)	F	No Trend		
RN028926	Nitrite (as N)	T	No Change	0	0
RN028926	Nitrogen (Total)	T	No Trend	0.344096	1.77417
RN028926	pH (Field)	T	No Trend	0.16378	0.989588
RN028926	Phosphorus	T	No Trend	0.163674	1.083623
RN028926	Potassium	F	No Trend	0.217436	1.291164
RN028926	Potassium	T	No Trend	1.66E-02	0.290598
RN028926	Selenium	F	No Change	0	0
RN028926	Silver	F	No Change	0	0
RN028926	Sodium	F	No Trend	4.75E-04	5.34E-02
RN028926	Sodium	T	No Trend	2.12E-02	0.329441
RN028926	Strontium	F	No Trend	0.11949	0.823729
RN028926	Sulphate	T	Down	0.456395	2.244421
RN028926	TDS	F	No Trend	2.82E-02	0.417359
RN028926	Temp (Field)	T	No Trend	0.393007	1.799257
RN028926	Thallium	F	No Change	0	0
RN028926	Thiocyanic Acid	T	No Trend	1.55E-02	0.30687
RN028926	Thorium	F	No Change	0	0
RN028926	Tin	F	No Change	0	0
RN028926	Titanium	F	No Change	0	0
RN028926	Uranium	F	No Change	0	0
RN028926	Vanadium	F	No Change	0	0
RN028926	Weak Acid Dissociable Cyanide	T	No Change	0	0
RN028926	Zinc	F	No Trend	0.125397	0.846689
RN028926	Zinc	T	No Trend	1.74E-02	0.297792

Mt Todd Groundwater Trend Analysis 2011 -2019

SW04MB01	Alkalinity (Bicarbonate as CaCO3)	T	No Trend	0.252624	0.82221
SW04MB01	Alkalinity (Bicarbonate)	T	No Trend	0.252624	0.82221
SW04MB01	Alkalinity (Carbonate as CaCO3)	T	No Change	0	0
SW04MB01	Alkalinity (Carbonate)	T	No Change	0	0
SW04MB01	Alkalinity (Hydroxide)	T	No Trend		
SW04MB01	Alkalinity (Hydroxide) as CaCO3	T	No Trend		
SW04MB01	Alkalinity (total)	T	No Trend		
SW04MB01	Alkalinity (total) as CaCO3	T	No Trend		
SW04MB01	Aluminium	F	No Change	0	0
SW04MB01	Aluminium	T	No Trend	0.131709	0.550795
SW04MB01	Ammonia as N	F	No Trend	0.475284	1.345951
SW04MB01	Anions Total	T	No Trend		
SW04MB01	Antimony	F	No Change	0	0
SW04MB01	Arsenic	F	No Trend	0.057985	0.350867
SW04MB01	Arsenic	T	No Trend	0.174076	0.649254
SW04MB01	Barium	F	No Trend	0.261716	0.842013
SW04MB01	Beryllium	F	No Change	0	0
SW04MB01	Bismuth	F	No Change	0	0
SW04MB01	Boron	F	No Trend	1.25E-02	0.159183
SW04MB01	Cadmium	F	No Change	0	0
SW04MB01	Cadmium	T	No Change	0	0
SW04MB01	Calcium	F	No Trend	0.253659	0.824463
SW04MB01	Calcium	T	No Trend	0.337954	1.010415
SW04MB01	Carbonate Alkalinity as CaCO3_	T	No Trend		
SW04MB01	Cations Total	T	No Trend		
SW04MB01	Chloride	T	No Trend	6.22E-02	0.364326
SW04MB01	Chromium (III+VI)	F	No Change	0	0
SW04MB01	Cobalt	F	No Trend	0.264705	0.848525
SW04MB01	Cobalt	T	No Trend	1.35E-02	0.165582
SW04MB01	Copper	F	No Trend	0.19225	0.689938
SW04MB01	Copper	T	No Trend	3.89E-02	0.284604
SW04MB01	Cyanide (amenable)	T	No Change	0	0
SW04MB01	Cyanide (Free)	T	No Change	0	0
SW04MB01	Cyanide Total	T	No Change	0	0
SW04MB01	DO (Field)	T	No Trend	0.974756	6.213959
SW04MB01	EC (field)	T	No Trend	5.02E-02	0.727179
SW04MB01	Hardness as CaCO3	T	No Trend		
SW04MB01	Hydroxide as CaCO3	T	No Trend		
SW04MB01	Ionic Balance	T	No Trend	0.175306	0.652029
SW04MB01	Iron	F	No Trend	0.504044	1.425698
SW04MB01	Iron	T	No Trend	0.62011	1.806843
SW04MB01	Kjeldahl Nitrogen Total	F	No Trend	6.00E-02	0.357168
SW04MB01	Lead	F	No Change	0	0
SW04MB01	Lead	T	No Change	0	0
SW04MB01	Lithium	F	No Trend	0.375816	1.097353
SW04MB01	Magnesium	F	No Trend	4.80E-02	0.317485
SW04MB01	Magnesium	T	No Trend	7.11E-02	0.391402
SW04MB01	Manganese	F	No Trend	0.451737	1.283698
SW04MB01	Manganese	T	No Trend	0.478288	1.354079
SW04MB01	Mercury	T	No Change	0	0
SW04MB01	Molybdenum	F	No Trend	0.395025	1.14277
SW04MB01	Nickel	F	No Change	0	0
SW04MB01	Nickel	T	No Trend	0.19225	0.689938
SW04MB01	Nitrate (as N)	F	No Trend	0.376865	1.099809
SW04MB01	Nitrite (as N)	F	No Trend		
SW04MB01	Nitrite (as N)	T	No Trend	6.59E-13	8.12E-07

Mt Todd Groundwater Trend Analysis 2011 -2019

SW04MB01	Nitrogen (Total)	T	No Trend	1.16E-02	0.153536
SW04MB01	pH (Field)	T	No Trend	3.08E-02	0.564045
SW04MB01	Phosphorus	T	No Trend	0.307855	0.943168
SW04MB01	Potassium	F	No Trend	5.02E-02	0.324995
SW04MB01	Potassium	T	No Trend	2.31E-02	0.217596
SW04MB01	Selenium	F	No Change	0	0
SW04MB01	Silver	F	No Change	0	0
SW04MB01	Sodium	F	No Trend	0.120344	0.523084
SW04MB01	Sodium	T	No Trend	0.495196	1.400692
SW04MB01	Strontium	F	No Trend	0.230477	0.773958
SW04MB01	Sulphate	T	No Trend	0.355266	1.049788
SW04MB01	TDS	F	No Trend	0.500565	1.415814
SW04MB01	Temp (Field)	T	No Trend	8.33E-04	9.13E-02
SW04MB01	Thallium	F	No Change	0	0
SW04MB01	Thiocyanic Acid	T	No Trend	0.138656	0.567408
SW04MB01	Thorium	F	No Change	0	0
SW04MB01	Tin	F	No Change	0	0
SW04MB01	Titanium	F	No Change	0	0
SW04MB01	Uranium	F	No Change	0	0
SW04MB01	Vanadium	F	No Change	0	0
SW04MB01	Weak Acid Dissociable Cyanide	T	No Change	0	0
SW04MB01	Zinc	F	No Trend	6.69E-04	3.66E-02
SW04MB01	Zinc	T	No Trend	7.18E-02	0.39332
TD2D	Alkalinity (Bicarbonate)	T	No Trend		
TD2D	Alkalinity (Carbonate)	T	No Trend		
TD2D	Alkalinity (total)	T	No Trend		
TD2D	Aluminium	F	No Trend		
TD2D	Aluminium	T	No Trend		
TD2D	Arsenic	F	No Trend		
TD2D	Arsenic	T	No Trend		
TD2D	Cadmium	F	No Trend		
TD2D	Cadmium	T	No Trend		
TD2D	Calcium	F	No Trend		
TD2D	Chloride	T	No Trend		
TD2D	Cobalt	F	No Trend		
TD2D	Cobalt	T	No Trend		
TD2D	Copper	F	No Trend		
TD2D	Copper	T	No Trend		
TD2D	EC (field)	T	No Trend		
TD2D	Hydroxide	T	No Trend		
TD2D	Iron	F	No Trend		
TD2D	Iron	T	No Trend		
TD2D	Lead	F	No Trend		
TD2D	Lead	T	No Trend		
TD2D	Magnesium	F	No Trend		
TD2D	Manganese	F	No Trend		
TD2D	Manganese	T	No Trend		
TD2D	Nickel	F	No Trend		
TD2D	Nickel	T	No Trend		
TD2D	Potassium	F	No Trend		
TD2D	Sodium	F	No Trend		
TD2D	Sulphate	F	No Trend		
TD2D	Zinc	F	No Trend		
TD2D	Zinc	T	No Trend		
TD2S	Alkalinity (Bicarbonate as CaCO3)	T	No Trend		
TD2S	Alkalinity (Bicarbonate)	T	No Trend		

Mt Todd Groundwater Trend Analysis 2011 -2019

TD2S	Alkalinity (Carbonate)	T	No Trend
TD2S	Aluminium	F	No Trend
TD2S	Aluminium	T	No Trend
TD2S	Ammonia as N	T	No Trend
TD2S	Antimony	F	No Trend
TD2S	Arsenic	F	No Trend
TD2S	Arsenic	T	No Trend
TD2S	Barium	F	No Trend
TD2S	Beryllium	F	No Trend
TD2S	Bismuth	F	No Trend
TD2S	Boron	F	No Trend
TD2S	Cadmium	F	No Trend
TD2S	Cadmium	T	No Trend
TD2S	Calcium	T	No Trend
TD2S	Carbonate Alkalinity as CaCO3_	T	No Trend
TD2S	Chloride	T	No Trend
TD2S	Chromium (III+VI)	F	No Trend
TD2S	Cobalt	F	No Trend
TD2S	Cobalt	T	No Trend
TD2S	Copper	F	No Trend
TD2S	Copper	T	No Trend
TD2S	Cyanide (amenable)	T	No Trend
TD2S	Cyanide (Free)	T	No Trend
TD2S	Cyanide Total	T	No Trend
TD2S	Iron	F	No Trend
TD2S	Iron	T	No Trend
TD2S	Kjeldahl Nitrogen Total	T	No Trend
TD2S	Lead	F	No Trend
TD2S	Lead	T	No Trend
TD2S	Lithium	F	No Trend
TD2S	Magnesium	T	No Trend
TD2S	Manganese	F	No Trend
TD2S	Manganese	T	No Trend
TD2S	Mercury	F	No Trend
TD2S	Molybdenum	F	No Trend
TD2S	Nickel	F	No Trend
TD2S	Nickel	T	No Trend
TD2S	Nitrate (as N)	F	No Trend
TD2S	Nitrite (as N)	F	No Trend
TD2S	Nitrogen (Total)	T	No Trend
TD2S	Phosphate total (as P)	T	No Trend
TD2S	Potassium	T	No Trend
TD2S	Selenium	F	No Trend
TD2S	Silver	F	No Trend
TD2S	Sodium	T	No Trend
TD2S	Strontium	F	No Trend
TD2S	Sulphate as S	T	No Trend
TD2S	TDS	F	No Trend
TD2S	Thallium	F	No Trend
TD2S	Thiocyanic Acid	T	No Trend
TD2S	Thorium	F	No Trend
TD2S	Tin	F	No Trend
TD2S	Titanium	F	No Trend
TD2S	Uranium	F	No Trend
TD2S	Vanadium	F	No Trend
TD2S	Weak Acid Dissociable Cyanide	T	No Trend

Mt Todd Groundwater Trend Analysis 2011 -2019

TD2S	Zinc	F	No Trend
TD2S	Zinc	T	No Trend
TD3D	Alkalinity (Bicarbonate)	T	No Trend
TD3D	Alkalinity (Carbonate)	T	No Trend
TD3D	Alkalinity (total)	T	No Trend
TD3D	Aluminium	F	No Trend
TD3D	Aluminium	T	No Trend
TD3D	Arsenic	F	No Trend
TD3D	Arsenic	T	No Trend
TD3D	Cadmium	F	No Trend
TD3D	Cadmium	T	No Trend
TD3D	Calcium	F	No Trend
TD3D	Chloride	T	No Trend
TD3D	Cobalt	F	No Trend
TD3D	Cobalt	T	No Trend
TD3D	Copper	F	No Trend
TD3D	Copper	T	No Trend
TD3D	EC (field)	T	No Trend
TD3D	Hydroxide	T	No Trend
TD3D	Iron	F	No Trend
TD3D	Iron	T	No Trend
TD3D	Lead	F	No Trend
TD3D	Lead	T	No Trend
TD3D	Magnesium	F	No Trend
TD3D	Manganese	F	No Trend
TD3D	Manganese	T	No Trend
TD3D	Nickel	F	No Trend
TD3D	Nickel	T	No Trend
TD3D	Potassium	F	No Trend
TD3D	Sodium	F	No Trend
TD3D	Sulphate	F	No Trend
TD3D	Zinc	F	No Trend
TD3D	Zinc	T	No Trend
TD3S	Alkalinity (Bicarbonate)	T	No Trend
TD3S	Alkalinity (Carbonate)	T	No Trend
TD3S	Alkalinity (total)	T	No Trend
TD3S	Aluminium	F	No Trend
TD3S	Aluminium	T	No Trend
TD3S	Anions Total	T	No Trend
TD3S	Arsenic	F	No Trend
TD3S	Arsenic	T	No Trend
TD3S	Cadmium	F	No Trend
TD3S	Cadmium	T	No Trend
TD3S	Calcium	F	No Trend
TD3S	Cations Total	T	No Trend
TD3S	Chloride	T	No Trend
TD3S	Cobalt	F	No Trend
TD3S	Cobalt	T	No Trend
TD3S	Copper	F	No Trend
TD3S	Copper	T	No Trend
TD3S	Hydroxide	T	No Trend
TD3S	Ionic Balance	T	No Trend
TD3S	Iron	F	No Trend
TD3S	Iron	T	No Trend
TD3S	Lead	F	No Trend
TD3S	Lead	T	No Trend

Mt Todd Groundwater Trend Analysis 2011 -2019

TD3S	Magnesium	F	No Trend
TD3S	Manganese	F	No Trend
TD3S	Manganese	T	No Trend
TD3S	Nickel	F	No Trend
TD3S	Nickel	T	No Trend
TD3S	Potassium	F	No Trend
TD3S	Sodium	F	No Trend
TD3S	Sulphate	F	No Trend
TD3S	Zinc	F	No Trend
TD3S	Zinc	T	No Trend
TD4D	Alkalinity (Bicarbonate)	T	No Trend
TD4D	Alkalinity (Carbonate)	T	No Trend
TD4D	Alkalinity (total)	T	No Trend
TD4D	Aluminium	F	No Trend
TD4D	Aluminium	T	No Trend
TD4D	Arsenic	F	No Trend
TD4D	Arsenic	T	No Trend
TD4D	Cadmium	F	No Trend
TD4D	Cadmium	T	No Trend
TD4D	Calcium	F	No Trend
TD4D	Chloride	T	No Trend
TD4D	Cobalt	F	No Trend
TD4D	Cobalt	T	No Trend
TD4D	Copper	F	No Trend
TD4D	Copper	T	No Trend
TD4D	EC (field)	T	No Trend
TD4D	Hydroxide	T	No Trend
TD4D	Iron	F	No Trend
TD4D	Iron	T	No Trend
TD4D	Lead	F	No Trend
TD4D	Lead	T	No Trend
TD4D	Magnesium	F	No Trend
TD4D	Manganese	F	No Trend
TD4D	Manganese	T	No Trend
TD4D	Nickel	F	No Trend
TD4D	Nickel	T	No Trend
TD4D	Potassium	F	No Trend
TD4D	Sodium	F	No Trend
TD4D	Sulphate	F	No Trend
TD4D	Zinc	F	No Trend
TD4D	Zinc	T	No Trend
TDMB02D	Alkalinity (Bicarbonate as CaCO3)	T	No Trend
TDMB02D	Alkalinity (Bicarbonate)	T	No Trend
TDMB02D	Alkalinity (Carbonate)	T	No Trend
TDMB02D	Aluminium	F	No Trend
TDMB02D	Aluminium	T	No Trend
TDMB02D	Ammonia as N	T	No Trend
TDMB02D	Antimony	F	No Trend
TDMB02D	Arsenic	F	No Trend
TDMB02D	Arsenic	T	No Trend
TDMB02D	Barium	F	No Trend
TDMB02D	Beryllium	F	No Trend
TDMB02D	Bismuth	F	No Trend
TDMB02D	Boron	F	No Trend
TDMB02D	Cadmium	F	No Trend
TDMB02D	Cadmium	T	No Trend

Mt Todd Groundwater Trend Analysis 2011 -2019

TDMB02D	Calcium	T	No Trend		
TDMB02D	Carbonate Alkalinity as CaCO3_	T	No Trend		
TDMB02D	Chloride	T	No Trend		
TDMB02D	Chromium (III+VI)	F	No Trend		
TDMB02D	Cobalt	F	No Trend		
TDMB02D	Cobalt	T	No Trend		
TDMB02D	Copper	F	No Trend		
TDMB02D	Copper	T	No Trend		
TDMB02D	Cyanide (amenable)	T	No Trend		
TDMB02D	Cyanide (Free)	T	No Trend		
TDMB02D	Cyanide Total	T	No Trend		
TDMB02D	Iron	F	No Trend		
TDMB02D	Iron	T	No Trend		
TDMB02D	Kjeldahl Nitrogen Total	T	No Change	0	0
TDMB02D	Lead	F	No Trend		
TDMB02D	Lead	T	No Trend		
TDMB02D	Lithium	F	No Trend		
TDMB02D	Magnesium	T	No Trend		
TDMB02D	Manganese	F	No Trend		
TDMB02D	Manganese	T	No Trend		
TDMB02D	Mercury	F	No Trend		
TDMB02D	Molybdenum	F	No Trend		
TDMB02D	Nickel	F	No Trend		
TDMB02D	Nickel	T	No Trend		
TDMB02D	Nitrate (as N)	F	No Change	0	0
TDMB02D	Nitrite (as N)	F	No Trend		
TDMB02D	Nitrogen (Total)	T	No Trend		
TDMB02D	Phosphate total (as P)	T	No Trend		
TDMB02D	Potassium	T	No Trend		
TDMB02D	Selenium	F	No Trend		
TDMB02D	Silver	F	No Trend		
TDMB02D	Sodium	T	No Trend		
TDMB02D	Strontium	F	No Trend		
TDMB02D	Sulphate as S	T	No Trend		
TDMB02D	TDS	F	No Trend		
TDMB02D	Thallium	F	No Trend		
TDMB02D	Thiocyanic Acid	T	No Trend		
TDMB02D	Thorium	F	No Trend		
TDMB02D	Tin	F	No Trend		
TDMB02D	Titanium	F	No Trend		
TDMB02D	Uranium	F	No Trend		
TDMB02D	Vanadium	F	No Trend		
TDMB02D	Weak Acid Dissociable Cyanide	T	No Trend		
TDMB02D	Zinc	F	No Trend		
TDMB02D	Zinc	T	No Trend		
TDMB1D	Alkalinity (Bicarbonate as CaCO3)	T	No Trend	7.62E-02	1.148689
TDMB1D	Alkalinity (Bicarbonate)	T	Up	0.356819	3.160048
TDMB1D	Alkalinity (Carbonate as CaCO3)	T	No Change	0	0
TDMB1D	Alkalinity (Carbonate)	T	No Trend	4.48E-02	0.943563
TDMB1D	Alkalinity (Hydroxide)	T	No Change	0	0
TDMB1D	Alkalinity (Hydroxide) as CaCO3	T	No Change	0	0
TDMB1D	Alkalinity (total)	T	No Trend	3.92E-03	0.125433
TDMB1D	Alkalinity (total) as CaCO3	T	No Trend	1.70E-02	0.394065
TDMB1D	Aluminium	F	Down	0.291365	2.399226
TDMB1D	Aluminium	T	Down	0.501446	3.752495
TDMB1D	Ammonia as N	F	No Trend	1.62E-04	0.045961

Mt Todd Groundwater Trend Analysis 2011 -2019

TDMB1D	Ammonia as N	T	No Trend	0.369858	1.326964
TDMB1D	Anions Total	T	No Trend	0.284892	0.631181
TDMB1D	Antimony	F	Down	0.400321	2.94589
TDMB1D	Arsenic	F	Down	0.478993	3.587626
TDMB1D	Arsenic	T	Down	0.487068	3.646104
TDMB1D	Barium	F	Down	0.692167	5.406536
TDMB1D	Beryllium	F	Down	0.400321	2.94589
TDMB1D	Bismuth	F	Down	0.315023	2.445144
TDMB1D	Boron	F	No Trend	0.053313	0.855629
TDMB1D	Cadmium	F	Down	0.680027	5.454696
TDMB1D	Cadmium	T	Down	0.680027	5.454696
TDMB1D	Calcium	F	No Trend	0.146135	1.547912
TDMB1D	Calcium	T	No Trend	9.65E-02	1.265406
TDMB1D	Carbonate Alkalinity as CaCO3_	T	Down	0.992945	16.77805
TDMB1D	Cations Total	T	Up	0.99669	17.35162
TDMB1D	Chloride	T	Down	0.893126	12.26467
TDMB1D	Chromium (III+VI)	F	No Change	0	0
TDMB1D	Cobalt	F	No Trend	0.180217	1.754334
TDMB1D	Cobalt	T	Down	0.187155	1.795398
TDMB1D	Copper	F	No Trend	8.71E-03	0.350671
TDMB1D	Copper	T	No Trend	0.158948	1.626598
TDMB1D	Cyanide (amenable)	T	Up	0.377841	3.213132
TDMB1D	Cyanide (Free)	T	No Trend	0.148757	1.672136
TDMB1D	Cyanide Total	T	Up	0.37127	3.073778
TDMB1D	DO (Field)	T	No Trend	0.100817	0.669688
TDMB1D	EC (field)	T	Up	0.426155	3.337581
TDMB1D	Hardness as CaCO3	T	No Trend		
TDMB1D	Hydroxide	T	No Trend		
TDMB1D	Hydroxide as CaCO3	T	No Trend		
TDMB1D	Ionic Balance	T	Up	0.399132	2.823315
TDMB1D	Iron	F	Down	0.334024	2.649864
TDMB1D	Iron	T	Down	0.354534	2.773039
TDMB1D	Kjeldahl Nitrogen Total	F	No Trend	8.14E-02	1.073031
TDMB1D	Kjeldahl Nitrogen Total	T	No Trend	0.473315	1.895963
TDMB1D	Lead	F	Up	0.271532	2.284386
TDMB1D	Lead	T	No Trend	0.16456	1.660616
TDMB1D	Lithium	F	No Trend	0.117921	1.318297
TDMB1D	Magnesium	F	Up	0.31809	2.555499
TDMB1D	Magnesium	T	Up	0.335322	2.750878
TDMB1D	Manganese	F	No Trend	0.032758	0.688585
TDMB1D	Manganese	T	No Trend	2.67E-03	0.193636
TDMB1D	Mercury	F	No Change	0	0
TDMB1D	Mercury	T	No Trend	1.86E-02	0.456004
TDMB1D	Molybdenum	F	Down	0.352687	2.661395
TDMB1D	Nickel	F	Down	0.360451	2.808993
TDMB1D	Nickel	T	No Trend	3.48E-03	0.221182
TDMB1D	Nitrate (as N)	F	Down	0.165933	1.94421
TDMB1D	Nitrate (as N)	T	No Trend		
TDMB1D	Nitrite (as N)	F	No Trend	0.170446	0.641042
TDMB1D	Nitrite (as N)	T	No Trend	2.17E-13	1.68E-06
TDMB1D	Nitrogen (Total)	T	No Trend	3.30E-02	0.761223
TDMB1D	pH (Field)	T	No Trend	0.106057	1.334014
TDMB1D	Phosphate total (as P)	T	No Trend	0.355263	0.742307
TDMB1D	Phosphorus	T	No Trend	0.155074	1.602968
TDMB1D	Potassium	F	Up	0.603901	4.620028
TDMB1D	Potassium	T	Up	0.462288	3.591095

Mt Todd Groundwater Trend Analysis 2011 -2019

TDMB1D	Selenium	F	Down	0.517763	3.735998
TDMB1D	Silver	F	Down	0.352687	2.661395
TDMB1D	Sodium	F	Up	0.681384	5.471746
TDMB1D	Sodium	T	Up	0.615701	4.902253
TDMB1D	Strontium	F	Up	0.23594	2.003587
TDMB1D	Sulphate	F	No Trend		
TDMB1D	Sulphate	T	No Trend	6.73E-04	9.71E-02
TDMB1D	Sulphate as S	T	No Trend	0.171247	0.642857
TDMB1D	TDS	F	No Trend	8.24E-03	0.341009
TDMB1D	TDS	T	No Trend		
TDMB1D	Temp (Field)	T	Up	0.314673	2.62438
TDMB1D	Thallium	F	No Trend	0.157106	1.556615
TDMB1D	Thiocyanates (total)	T	No Trend		
TDMB1D	Thiocyanic Acid	T	No Trend	8.15E-03	0.314019
TDMB1D	Thiosulphate	T	No Trend		
TDMB1D	Thorium	F	Down	0.227556	1.956959
TDMB1D	Tin	F	Down	0.400321	2.94589
TDMB1D	Titanium	F	Down	0.363427	2.724308
TDMB1D	Uranium	F	Down	0.366446	2.74211
TDMB1D	Vanadium	F	Down	0.352687	2.661395
TDMB1D	Weak Acid Dissociable Cyanide	T	Down	0.310113	2.681828
TDMB1D	Zinc	F	No Trend	1.17E-03	0.128021
TDMB1D	Zinc	T	No Trend	0.104004	1.274783
TDMB2D	Alkalinity (Bicarbonate as CaCO3)	T	Up	0.396843	3.034999
TDMB2D	Alkalinity (Bicarbonate)	T	Up	0.265136	2.402651
TDMB2D	Alkalinity (Carbonate as CaCO3)	T	No Change	0	0
TDMB2D	Alkalinity (Carbonate)	T	Down	0.182623	1.948906
TDMB2D	Alkalinity (Hydroxide)	T	No Change	0	0
TDMB2D	Alkalinity (Hydroxide) as CaCO3	T	No Change	0	0
TDMB2D	Alkalinity (total)	T	No Trend	0.350705	1.469875
TDMB2D	Alkalinity (total) as CaCO3	T	Up	0.352732	2.087974
TDMB2D	Aluminium	F	Down	0.246413	2.214677
TDMB2D	Aluminium	T	No Trend	3.29E-02	0.714341
TDMB2D	Ammonia as N	F	Down	0.320527	2.37923
TDMB2D	Ammonia as N	T	No Trend	0.348613	1.267105
TDMB2D	Anions Total	T	No Trend	0.104538	0.341675
TDMB2D	Antimony	F	No Trend	0.173724	1.715658
TDMB2D	Arsenic	F	Down	0.226089	2.093343
TDMB2D	Arsenic	T	No Trend	5.49E-02	0.933854
TDMB2D	Barium	F	No Trend	6.57E-02	0.992192
TDMB2D	Beryllium	F	Down	0.316566	2.546523
TDMB2D	Bismuth	F	Down	0.229433	2.041673
TDMB2D	Boron	F	No Trend	0.071695	1.039828
TDMB2D	Cadmium	F	Down	0.233367	2.13684
TDMB2D	Cadmium	T	No Trend	5.71E-02	0.952962
TDMB2D	Calcium	F	No Trend	6.15E-03	0.294341
TDMB2D	Calcium	T	No Trend	0.132022	1.459263
TDMB2D	Carbonate Alkalinity as CaCO3_	T	Down	0.998107	22.96078
TDMB2D	Cations Total	T	No Trend	7.77E-02	0.2902
TDMB2D	Chloride	T	No Trend	0.12584	1.517657
TDMB2D	Chromium (III+VI)	F	No Change	0	0
TDMB2D	Cobalt	F	No Trend	4.85E-03	0.270453
TDMB2D	Cobalt	T	Down	0.329676	2.716106
TDMB2D	Copper	F	No Trend	7.91E-02	1.135119
TDMB2D	Copper	T	No Trend	5.79E-02	0.960235
TDMB2D	Cyanide (amenable)	T	Down	0.22834	2.035363

Mt Todd Groundwater Trend Analysis 2011 -2019

TDMB2D	Cyanide (Free)	T	No Trend	0.168591	1.744038
TDMB2D	Cyanide Total	T	Down	0.325628	2.77953
TDMB2D	DO (Field)	T	No Trend	4.19E-02	0.467367
TDMB2D	EC (field)	T	No Trend	3.99E-02	0.789788
TDMB2D	Hardness as CaCO3	T	No Trend		
TDMB2D	Hydroxide	T	No Trend		
TDMB2D	Hydroxide as CaCO3	T	No Trend		
TDMB2D	Ionic Balance	T	Up	0.318361	2.464076
TDMB2D	Iron	F	Down	0.702833	5.956235
TDMB2D	Iron	T	Down	0.36912	2.962485
TDMB2D	Kjeldahl Nitrogen Total	F	No Trend	0.127467	1.32403
TDMB2D	Kjeldahl Nitrogen Total	T	No Trend	0.217515	0.745628
TDMB2D	Lead	F	No Trend	2.01E-02	0.554242
TDMB2D	Lead	T	No Trend	5.65E-02	0.948111
TDMB2D	Lithium	F	No Trend	0.128278	1.43533
TDMB2D	Magnesium	F	No Trend	3.18E-02	0.677993
TDMB2D	Magnesium	T	Up	0.417823	3.169807
TDMB2D	Manganese	F	Down	0.472579	3.6661
TDMB2D	Manganese	T	Down	0.184184	1.840243
TDMB2D	Mercury	F	No Trend		
TDMB2D	Mercury	T	No Trend	5.26E-02	0.781195
TDMB2D	Molybdenum	F	Down	0.246737	2.141452
TDMB2D	Nickel	F	No Trend	4.41E-03	0.257817
TDMB2D	Nickel	T	No Trend	5.00E-02	0.888947
TDMB2D	Nitrate (as N)	F	No Trend	1.85E-02	0.548873
TDMB2D	Nitrate (as N)	T	No Trend		
TDMB2D	Nitrite (as N)	F	No Trend	0.304904	0.662307
TDMB2D	Nitrite (as N)	T	No Trend	9.28E-03	0.348933
TDMB2D	Nitrogen (Total)	T	No Trend	7.95E-02	1.137965
TDMB2D	pH (Field)	T	No Trend	0.113743	1.387488
TDMB2D	Phosphate total (as P)	T	No Trend		
TDMB2D	Phosphorus	T	Up	0.252507	2.095582
TDMB2D	Potassium	F	No Trend	9.23E-02	1.192826
TDMB2D	Potassium	T	No Trend	7.74E-03	0.330502
TDMB2D	Selenium	F	Down	0.338453	2.676288
TDMB2D	Silver	F	Down	0.267498	2.261102
TDMB2D	Sodium	F	Down	0.311773	2.518357
TDMB2D	Sodium	T	Down	0.359114	2.800847
TDMB2D	Strontium	F	Up	0.52694	3.948992
TDMB2D	Sulphate	F	No Trend		
TDMB2D	Sulphate	T	Down	0.211546	1.867609
TDMB2D	Sulphate as S	T	No Trend	0.930412	3.656552
TDMB2D	TDS	F	No Trend	2.02E-02	0.556649
TDMB2D	TDS	T	No Trend		
TDMB2D	Temp (Field)	T	Up	0.178039	1.802509
TDMB2D	Thallium	F	No Trend	0.178931	1.746697
TDMB2D	Thiocyanates (total)	T	No Trend		
TDMB2D	Thiocyanic Acid	T	Down	0.374183	2.678608
TDMB2D	Thiosulphate	T	No Trend		
TDMB2D	Thorium	F	No Trend	0.139138	1.504249
TDMB2D	Tin	F	Down	0.245016	2.131533
TDMB2D	Titanium	F	Down	0.333175	2.644809
TDMB2D	Uranium	F	Down	0.285648	2.366047
TDMB2D	Vanadium	F	Down	0.267498	2.261102
TDMB2D	Weak Acid Dissociable Cyanide	T	Down	0.376257	3.106702
TDMB2D	Zinc	F	Down	0.195432	1.908806

Mt Todd Groundwater Trend Analysis 2011 -2019

TDMB2D	Zinc	T	No Trend	6.60E-02	1.029482
TDMB2S	Alkalinity (Bicarbonate as CaCO3)	T	Up	0.382518	2.837826
TDMB2S	Alkalinity (Bicarbonate)	T	No Trend	0.157912	1.677158
TDMB2S	Alkalinity (Carbonate as CaCO3)	T	No Change	0	0
TDMB2S	Alkalinity (Carbonate)	T	Down	0.224063	2.149474
TDMB2S	Alkalinity (Hydroxide)	T	No Change	0	0
TDMB2S	Alkalinity (Hydroxide) as CaCO3	T	No Change	0	0
TDMB2S	Alkalinity (total)	T	No Trend	0.082473	0.670396
TDMB2S	Alkalinity (total) as CaCO3	T	No Trend	1.74E-02	0.326183
TDMB2S	Aluminium	F	No Trend	0.160783	1.578176
TDMB2S	Aluminium	T	No Trend	9.13E-05	3.58E-02
TDMB2S	Ammonia as N	F	No Trend	5.47E-03	0.234426
TDMB2S	Ammonia as N	T	No Trend	0.448254	1.561182
TDMB2S	Anions Total	T	No Trend	0.142082	0.406956
TDMB2S	Antimony	F	Down	0.312499	2.335491
TDMB2S	Arsenic	F	Down	0.461577	3.338347
TDMB2S	Arsenic	T	No Trend	5.15E-02	0.871672
TDMB2S	Barium	F	No Trend	5.85E-02	0.863581
TDMB2S	Beryllium	F	Down	0.372113	2.666781
TDMB2S	Bismuth	F	Down	0.266623	2.088701
TDMB2S	Boron	F	Up	0.223181	1.856775
TDMB2S	Cadmium	F	No Trend	0.185837	1.722591
TDMB2S	Cadmium	T	No Trend	6.71E-02	1.003579
TDMB2S	Calcium	F	No Trend	7.78E-03	0.319169
TDMB2S	Calcium	T	No Trend	0.118781	1.271809
TDMB2S	Carbonate Alkalinity as CaCO3_	T	Down	0.998737	39.76923
TDMB2S	Cations Total	T	No Trend	5.60E-02	0.344552
TDMB2S	Chloride	T	Down	0.340528	2.688698
TDMB2S	Chromium (III+VI)	F	No Trend	0.01079	0.361793
TDMB2S	Cobalt	F	No Trend	0.140632	1.458559
TDMB2S	Cobalt	T	Down	0.43505	3.283437
TDMB2S	Copper	F	No Trend	4.80E-02	0.809363
TDMB2S	Copper	T	Up	0.322533	2.581705
TDMB2S	Cyanide (amenable)	T	Down	0.266552	2.255641
TDMB2S	Cyanide (Free)	T	No Trend	0.179144	1.747958
TDMB2S	Cyanide Total	T	Down	0.317149	2.639455
TDMB2S	DO (Field)	T	No Trend	0.267432	1.046509
TDMB2S	EC (field)	T	Up	0.170327	1.754823
TDMB2S	Hardness as CaCO3	T	No Trend		
TDMB2S	Hydroxide	T	No Trend		
TDMB2S	Hydroxide as CaCO3	T	No Trend		
TDMB2S	Ionic Balance	T	No Trend	0.132044	1.293622
TDMB2S	Iron	F	Down	0.525053	3.790969
TDMB2S	Iron	T	Down	0.464202	3.482706
TDMB2S	Kjeldahl Nitrogen Total	F	No Trend	7.27E-03	0.270644
TDMB2S	Kjeldahl Nitrogen Total	T	Up	0.922271	4.871402
TDMB2S	Lead	F	No Trend	0.011915	0.39593
TDMB2S	Lead	T	No Trend	4.07E-02	0.77096
TDMB2S	Lithium	F	Down	0.444792	3.100571
TDMB2S	Magnesium	F	No Trend	4.79E-02	0.80844
TDMB2S	Magnesium	T	Up	0.452134	3.146929
TDMB2S	Manganese	F	Down	0.649384	4.906895
TDMB2S	Manganese	T	Down	0.560643	4.226668
TDMB2S	Mercury	F	No Trend		
TDMB2S	Mercury	T	Down	0.382613	2.610942
TDMB2S	Molybdenum	F	Down	0.312499	2.335491

Mt Todd Groundwater Trend Analysis 2011 -2019

TDMB2S	Nickel	F	Down	0.606765	4.478739
TDMB2S	Nickel	T	Down	0.590322	4.491454
TDMB2S	Nitrate (as N)	F	No Trend	5.23E-03	0.271419
TDMB2S	Nitrate (as N)	T	No Trend		
TDMB2S	Nitrite (as N)	F	No Trend	0.38654	1.122584
TDMB2S	Nitrite (as N)	T	No Trend	9.66E-02	1.034009
TDMB2S	Nitrogen (Total)	T	No Trend	2.14E-02	0.553264
TDMB2S	pH (Field)	T	Up	0.302662	2.551544
TDMB2S	Phosphate total (as P)	T	No Trend		
TDMB2S	Phosphorus	T	No Trend	9.03E-02	1.044855
TDMB2S	Potassium	F	No Trend	0.013505	0.421867
TDMB2S	Potassium	T	Up	0.23106	1.898921
TDMB2S	Selenium	F	Down	0.403935	2.851672
TDMB2S	Silver	F	Down	0.312499	2.335491
TDMB2S	Sodium	F	No Trend	9.91E-02	1.196148
TDMB2S	Sodium	T	No Trend	9.19E-03	0.333597
TDMB2S	Strontium	F	Up	0.400597	2.831944
TDMB2S	Sulphate	F	No Trend		
TDMB2S	Sulphate	T	No Trend	7.88E-03	0.295537
TDMB2S	Sulphate as S	T	No Trend	0.970874	5.773503
TDMB2S	TDS	F	No Trend	1.60E-02	0.423365
TDMB2S	TDS	T	No Trend		
TDMB2S	Temp (Field)	T	Up	0.332219	2.731749
TDMB2S	Thallium	F	Up	0.217097	1.824161
TDMB2S	Thiocyanates (total)	T	No Trend		
TDMB2S	Thiocyanic Acid	T	Down	0.335867	2.248828
TDMB2S	Thiosulphate	T	No Trend		
TDMB2S	Thorium	F	No Trend	0.159596	1.509586
TDMB2S	Tin	F	Down	0.372113	2.666781
TDMB2S	Titanium	F	Down	0.403275	2.847766
TDMB2S	Uranium	F	Down	0.326607	2.412512
TDMB2S	Vanadium	F	Down	0.312499	2.335491
TDMB2S	Weak Acid Dissociable Cyanide	T	Down	0.438529	3.422797
TDMB2S	Zinc	F	No Trend	4.07E-02	0.742284
TDMB2S	Zinc	T	No Trend	0.104444	1.277788
TDMB3D	Alkalinity (Bicarbonate as CaCO3)	T	No Trend	7.21E-05	3.60E-02
TDMB3D	Alkalinity (Bicarbonate)	T	No Trend	0.101962	1.506907
TDMB3D	Alkalinity (Carbonate as CaCO3)	T	No Change	0	0
TDMB3D	Alkalinity (Carbonate)	T	No Trend	0.043694	0.979537
TDMB3D	Alkalinity (Hydroxide)	T	No Change	0	0
TDMB3D	Alkalinity (Hydroxide) as CaCO3	T	No Change	0	0
TDMB3D	Alkalinity (total)	T	Up	0.735718	3.730842
TDMB3D	Alkalinity (total) as CaCO3	T	Up	0.630909	4.134441
TDMB3D	Aluminium	F	Down	0.189462	2.162168
TDMB3D	Aluminium	T	No Trend	1.12E-02	0.475452
TDMB3D	Ammonia as N	F	No Trend	2.96E-02	0.676179
TDMB3D	Ammonia as N	T	Up	0.772519	3.191849
TDMB3D	Anions Total	T	No Trend	0.468628	1.328097
TDMB3D	Antimony	F	Down	0.285656	2.756419
TDMB3D	Arsenic	F	No Trend	6.83E-02	1.210612
TDMB3D	Arsenic	T	No Trend	4.75E-02	0.998152
TDMB3D	Barium	F	No Trend	1.74E-02	0.579272
TDMB3D	Beryllium	F	No Trend	0.104216	1.486762
TDMB3D	Bismuth	F	Down	0.264022	2.610747
TDMB3D	Boron	F	Down	0.13824	1.745822
TDMB3D	Cadmium	F	No Trend	4.98E-02	1.023627

Mt Todd Groundwater Trend Analysis 2011 -2019

TDMB3D	Cadmium	T	No Trend	2.26E-02	0.679279
TDMB3D	Calcium	F	No Trend	1.94E-02	0.580666
TDMB3D	Calcium	T	No Trend	6.90E-02	1.154972
TDMB3D	Carbonate Alkalinity as CaCO3_	T	Down	0.995574	25.9777
TDMB3D	Cations Total	T	No Trend	0.412167	1.1842
TDMB3D	Chloride	T	No Trend	2.66E-02	0.739526
TDMB3D	Chromium (III+VI)	F	Up	0.172971	1.99344
TDMB3D	Cobalt	F	Up	0.906437	13.91979
TDMB3D	Cobalt	T	Up	0.824429	9.690941
TDMB3D	Copper	F	No Trend	7.74E-02	1.295315
TDMB3D	Copper	T	No Trend	6.56E-02	1.184525
TDMB3D	Cyanide (amenable)	T	Up	0.391964	3.40639
TDMB3D	Cyanide (Free)	T	Down	0.148483	1.820199
TDMB3D	Cyanide Total	T	No Trend	3.90E-02	0.878018
TDMB3D	DO (Field)	T	No Trend	0.438312	1.975281
TDMB3D	EC (field)	T	No Trend	9.23E-02	1.275282
TDMB3D	Hardness as CaCO3	T	No Trend		
TDMB3D	Hydroxide	T	No Trend		
TDMB3D	Hydroxide as CaCO3	T	No Trend		
TDMB3D	Ionic Balance	T	Down	0.232647	2.060227
TDMB3D	Iron	F	No Trend	1.33E-03	0.163013
TDMB3D	Iron	T	No Trend	9.44E-04	0.13747
TDMB3D	Kjeldahl Nitrogen Total	F	No Trend	8.92E-02	1.212406
TDMB3D	Kjeldahl Nitrogen Total	T	No Trend	0.468014	1.8759
TDMB3D	Lead	F	Up	0.228675	2.435038
TDMB3D	Lead	T	No Trend	5.46E-02	1.074794
TDMB3D	Lithium	F	No Trend	6.00E-05	3.38E-02
TDMB3D	Magnesium	F	No Trend	9.75E-03	0.409082
TDMB3D	Magnesium	T	No Trend	5.00E-02	0.972949
TDMB3D	Manganese	F	No Trend	1.33E-03	0.162899
TDMB3D	Manganese	T	No Trend	8.83E-04	0.132955
TDMB3D	Mercury	F	No Change	0	0
TDMB3D	Mercury	T	Up	0.331784	2.636535
TDMB3D	Molybdenum	F	Down	0.308199	2.909387
TDMB3D	Nickel	F	No Trend	4.72E-03	0.307983
TDMB3D	Nickel	T	No Trend	1.76E-02	0.599085
TDMB3D	Nitrate (as N)	F	No Trend	8.70E-02	1.414252
TDMB3D	Nitrate (as N)	T	No Trend		
TDMB3D	Nitrite (as N)	F	No Trend	0.226818	0.938121
TDMB3D	Nitrite (as N)	T	No Trend	2.43E-13	1.85E-06
TDMB3D	Nitrogen (Total)	T	No Trend	6.90E-08	1.17E-03
TDMB3D	pH (Field)	T	No Trend	6.17E-02	1.025947
TDMB3D	Phosphate total (as P)	T	No Trend	0.964286	5.196152
TDMB3D	Phosphorus	T	No Trend	3.75E-02	0.789226
TDMB3D	Potassium	F	No Trend	2.49E-02	0.658677
TDMB3D	Potassium	T	No Trend	0.125592	1.607901
TDMB3D	Selenium	F	No Trend	0.132592	1.70421
TDMB3D	Silver	F	Down	0.266988	2.630677
TDMB3D	Sodium	F	No Trend	4.46E-03	0.27585
TDMB3D	Sodium	T	No Trend	7.30E-03	0.363893
TDMB3D	Strontium	F	No Trend	7.07E-02	1.202306
TDMB3D	Sulphate	F	No Trend		
TDMB3D	Sulphate	T	No Trend	1.47E-03	0.1534
TDMB3D	Sulphate as S	T	No Change	0	0
TDMB3D	TDS	F	No Trend	1.30E-02	0.47231
TDMB3D	TDS	T	No Trend		

Mt Todd Groundwater Trend Analysis 2011 -2019

TDMB3D	Temp (Field)	T	No Trend	0.137638	1.598029
TDMB3D	Thallium	F	No Trend	0.132592	1.70421
TDMB3D	Thiocyanates (total)	T	No Trend		
TDMB3D	Thiocyanic Acid	T	Down	0.337022	2.851934
TDMB3D	Thiosulphate	T	No Trend		
TDMB3D	Thorium	F	Down	0.199818	2.17821
TDMB3D	Tin	F	Down	0.270705	2.655668
TDMB3D	Titanium	F	Down	0.407419	3.614296
TDMB3D	Uranium	F	Down	0.306863	2.900277
TDMB3D	Vanadium	F	Down	0.270705	2.655668
TDMB3D	Weak Acid Dissociable Cyanide	T	Down	0.298726	2.844915
TDMB3D	Zinc	F	No Trend	7.57E-02	1.279426
TDMB3D	Zinc	T	No Trend	3.85E-02	0.895271
TDMB3S	Alkalinity (Bicarbonate as CaCO3)	T	No Trend		
TDMB3S	Alkalinity (Bicarbonate)	T	No Trend		
TDMB3S	Alkalinity (Carbonate)	T	No Trend		
TDMB3S	Aluminium	F	No Trend		
TDMB3S	Aluminium	T	No Trend		
TDMB3S	Ammonia as N	T	No Trend		
TDMB3S	Antimony	F	No Trend		
TDMB3S	Arsenic	F	No Trend		
TDMB3S	Arsenic	T	No Trend		
TDMB3S	Barium	F	No Trend		
TDMB3S	Beryllium	F	No Trend		
TDMB3S	Bismuth	F	No Trend		
TDMB3S	Boron	F	No Trend		
TDMB3S	Cadmium	F	No Trend		
TDMB3S	Cadmium	T	No Trend		
TDMB3S	Calcium	T	No Trend		
TDMB3S	Carbonate Alkalinity as CaCO3_	T	No Trend		
TDMB3S	Chloride	T	No Trend		
TDMB3S	Chromium (III+VI)	F	No Trend		
TDMB3S	Cobalt	F	No Trend		
TDMB3S	Cobalt	T	No Trend		
TDMB3S	Copper	F	No Trend		
TDMB3S	Copper	T	No Trend		
TDMB3S	Cyanide (amenable)	T	No Trend		
TDMB3S	Cyanide (Free)	T	No Trend		
TDMB3S	Cyanide Total	T	No Trend		
TDMB3S	EC (field)	T	No Trend		
TDMB3S	Iron	F	No Trend		
TDMB3S	Iron	T	No Trend		
TDMB3S	Kjeldahl Nitrogen Total	T	No Trend		
TDMB3S	Lead	F	No Trend		
TDMB3S	Lead	T	No Trend		
TDMB3S	Lithium	F	No Trend		
TDMB3S	Magnesium	T	No Trend		
TDMB3S	Manganese	F	No Trend		
TDMB3S	Manganese	T	No Trend		
TDMB3S	Mercury	F	No Trend		
TDMB3S	Molybdenum	F	No Trend		
TDMB3S	Nickel	F	No Trend		
TDMB3S	Nickel	T	No Trend		
TDMB3S	Nitrate (as N)	F	No Trend		
TDMB3S	Nitrite (as N)	F	No Trend		
TDMB3S	Nitrogen (Total)	T	No Trend		

Mt Todd Groundwater Trend Analysis 2011 -2019

TDMB3S	pH (Field)	T	No Trend		
TDMB3S	Potassium	T	No Trend		
TDMB3S	Selenium	F	No Trend		
TDMB3S	Silver	F	No Trend		
TDMB3S	Sodium	T	No Trend		
TDMB3S	Strontium	F	No Trend		
TDMB3S	Sulphate as S	T	No Trend		
TDMB3S	TDS	F	No Trend		
TDMB3S	Temp (Field)	T	No Trend		
TDMB3S	Thallium	F	No Trend		
TDMB3S	Thiocyanic Acid	T	No Trend		
TDMB3S	Thorium	F	No Trend		
TDMB3S	Tin	F	No Trend		
TDMB3S	Titanium	F	No Trend		
TDMB3S	Uranium	F	No Trend		
TDMB3S	Vanadium	F	No Trend		
TDMB3S	Weak Acid Dissociable Cyanide	T	No Trend		
TDMB3S	Zinc	F	No Trend		
TDMB3S	Zinc	T	No Trend		
TDMB4D	Alkalinity (Bicarbonate as CaCO3)	T	No Trend	5.21E-02	0.877148
TDMB4D	Alkalinity (Bicarbonate)	T	Up	0.17916	1.868748
TDMB4D	Alkalinity (Carbonate as CaCO3)	T	No Change	0	0
TDMB4D	Alkalinity (Carbonate)	T	No Trend	3.98E-02	0.839352
TDMB4D	Alkalinity (Hydroxide)	T	No Change	0	0
TDMB4D	Alkalinity (Hydroxide) as CaCO3	T	No Change	0	0
TDMB4D	Alkalinity (total)	T	Down	0.644977	2.695715
TDMB4D	Alkalinity (total) as CaCO3	T	Up	0.378265	2.063689
TDMB4D	Aluminium	F	Down	0.158391	1.788685
TDMB4D	Aluminium	T	Down	0.252597	2.251553
TDMB4D	Ammonia as N	F	No Trend	6.93E-02	0.905075
TDMB4D	Ammonia as N	T	No Trend	6.52E-04	4.42E-02
TDMB4D	Anions Total	T	No Trend	0.389354	0.798505
TDMB4D	Antimony	F	Down	0.269877	2.431898
TDMB4D	Arsenic	F	No Trend	9.07E-04	0.124236
TDMB4D	Arsenic	T	No Trend	8.40E-02	1.172656
TDMB4D	Barium	F	Up	0.62066	5.116498
TDMB4D	Beryllium	F	No Trend	0.101284	1.342822
TDMB4D	Bismuth	F	Down	0.263001	2.389492
TDMB4D	Boron	F	Down	0.220766	2.129081
TDMB4D	Cadmium	F	No Trend	1.95E-02	0.581529
TDMB4D	Cadmium	T	No Trend	2.14E-02	0.572078
TDMB4D	Calcium	F	Up	0.247337	2.220187
TDMB4D	Calcium	T	Up	0.226749	2.097285
TDMB4D	Carbonate Alkalinity as CaCO3_	T	Down	0.992937	16.76854
TDMB4D	Cations Total	T	Up	0.999997	606.2517
TDMB4D	Chloride	T	No Trend	6.70E-02	1.072107
TDMB4D	Chromium (III+VI)	F	No Trend	0.134342	1.575767
TDMB4D	Cobalt	F	No Trend	7.92E-02	1.208889
TDMB4D	Cobalt	T	No Trend	3.79E-02	0.768642
TDMB4D	Copper	F	Up	0.220321	2.191768
TDMB4D	Copper	T	No Trend	0.123264	1.452208
TDMB4D	Cyanide (amenable)	T	Down	0.190513	1.878896
TDMB4D	Cyanide (Free)	T	Down	0.193842	1.899152
TDMB4D	Cyanide Total	T	Down	0.277143	2.398121
TDMB4D	DO (Field)	T	No Trend	0.436956	1.761887
TDMB4D	EC (field)	T	Up	0.410213	3.230002

Mt Todd Groundwater Trend Analysis 2011 -2019

TDMB4D	Hardness as CaCO3	T	No Trend		
TDMB4D	Hydroxide	T	No Trend		
TDMB4D	Hydroxide as CaCO3	T	No Trend		
TDMB4D	Ionic Balance	T	No Trend	8.86E-03	0.299038
TDMB4D	Iron	F	No Trend	4.14E-02	0.856882
TDMB4D	Iron	T	No Trend	5.43E-02	0.927799
TDMB4D	Kjeldahl Nitrogen Total	F	No Trend	4.29E-02	0.733297
TDMB4D	Kjeldahl Nitrogen Total	T	No Trend	0.470671	1.885931
TDMB4D	Lead	F	Up	0.238355	2.306539
TDMB4D	Lead	T	No Trend	8.65E-02	1.191788
TDMB4D	Lithium	F	No Trend	1.93E-02	0.561725
TDMB4D	Magnesium	F	Up	0.456978	3.552916
TDMB4D	Magnesium	T	Up	0.390966	3.10309
TDMB4D	Manganese	F	Up	0.361139	3.099977
TDMB4D	Manganese	T	Up	0.408981	3.221787
TDMB4D	Mercury	F	No Change	0	0
TDMB4D	Mercury	T	Up	0.20961	1.78392
TDMB4D	Molybdenum	F	Down	0.285292	2.527203
TDMB4D	Nickel	F	Down	0.260687	2.448333
TDMB4D	Nickel	T	No Trend	9.11E-02	1.22639
TDMB4D	Nitrate (as N)	F	No Trend	0.112831	1.4704
TDMB4D	Nitrate (as N)	T	No Trend		
TDMB4D	Nitrite (as N)	F	No Trend	0.190423	0.685875
TDMB4D	Nitrite (as N)	T	No Trend	2.96E-13	1.81E-06
TDMB4D	Nitrogen (Total)	T	No Trend	5.01E-04	8.96E-02
TDMB4D	pH (Field)	T	No Trend	8.16E-03	0.351278
TDMB4D	Phosphate total (as P)	T	No Trend	5.77E-02	0.247436
TDMB4D	Phosphorus	T	No Trend	6.68E-02	0.964711
TDMB4D	Potassium	F	Up	0.567783	4.439004
TDMB4D	Potassium	T	Up	0.602223	4.765456
TDMB4D	Selenium	F	No Trend	0.134342	1.575767
TDMB4D	Silver	F	Down	0.266052	2.408299
TDMB4D	Sodium	F	No Trend	0.130667	1.501532
TDMB4D	Sodium	T	Up	0.333504	2.739667
TDMB4D	Strontium	F	Up	0.63202	5.242195
TDMB4D	Sulphate	F	No Trend		
TDMB4D	Sulphate	T	No Trend	0.179982	1.622907
TDMB4D	Sulphate as S	T	No Trend	7.36E-02	0.398708
TDMB4D	TDS	F	Up	0.363511	2.926908
TDMB4D	TDS	T	No Trend		
TDMB4D	Temp (Field)	T	No Trend	0.129598	1.494465
TDMB4D	Thallium	F	No Trend	0.134342	1.575767
TDMB4D	Thiocyanates (total)	T	No Trend		
TDMB4D	Thiocyanic Acid	T	No Trend	3.55E-04	6.53E-02
TDMB4D	Thiosulphate	T	No Trend		
TDMB4D	Thorium	F	Down	0.197162	1.982249
TDMB4D	Tin	F	Down	0.269877	2.431898
TDMB4D	Titanium	F	Down	0.412475	3.35155
TDMB4D	Uranium	F	Down	0.307092	2.662911
TDMB4D	Vanadium	F	Down	0.266052	2.408299
TDMB4D	Weak Acid Dissociable Cyanide	T	Down	0.181664	1.76292
TDMB4D	Zinc	F	Down	0.257358	2.42719
TDMB4D	Zinc	T	No Trend	3.91E-03	0.242583
TDMBD1	Alkalinity (Bicarbonate as CaCO3)	T	No Trend	3.71E-03	0.244023
TDMBD1	Alkalinity (Bicarbonate)	T	Up	0.138679	1.79448
TDMBD1	Alkalinity (Carbonate as CaCO3)	T	No Change	0	0

Mt Todd Groundwater Trend Analysis 2011 -2019

TDMBD1	Alkalinity (Carbonate)	T	No Trend	7.92E-02	1.343735
TDMBD1	Alkalinity (Hydroxide)	T	No Change	0	0
TDMBD1	Alkalinity (Hydroxide) as CaCO3	T	No Change	0	0
TDMBD1	Alkalinity (total)	T	Down	0.554327	3.154424
TDMBD1	Alkalinity (total) as CaCO3	T	No Trend	7.88E-02	0.71625
TDMBD1	Aluminium	F	No Trend	0.121531	1.533576
TDMBD1	Aluminium	T	No Trend	6.76E-02	1.14238
TDMBD1	Ammonia as N	F	No Trend	0.16122	1.518714
TDMBD1	Ammonia as N	T	No Trend	6.08E-02	0.509028
TDMBD1	Anions Total	T	Down	0.881651	3.859944
TDMBD1	Antimony	F	Down	0.353228	2.765134
TDMBD1	Arsenic	F	Up	0.442588	3.673975
TDMBD1	Arsenic	T	Up	0.316739	2.888645
TDMBD1	Barium	F	Down	0.579238	4.390095
TDMBD1	Beryllium	F	No Trend	0.166572	1.672753
TDMBD1	Bismuth	F	Down	0.349951	2.74533
TDMBD1	Boron	F	Down	0.324712	2.594587
TDMBD1	Cadmium	F	No Trend	1.57E-04	5.16E-02
TDMBD1	Cadmium	T	No Trend	1.52E-04	5.23E-02
TDMBD1	Calcium	F	Down	0.44603	3.357402
TDMBD1	Calcium	T	No Trend	0.126763	1.425587
TDMBD1	Carbonate Alkalinity as CaCO3_	T	Down	0.991133	18.31184
TDMBD1	Cations Total	T	No Trend	0.650782	1.930566
TDMBD1	Chloride	T	No Trend	6.25E-02	1.15427
TDMBD1	Chromium (III+VI)	F	No Trend	0.118794	1.373799
TDMBD1	Cobalt	F	Up	0.335037	2.926662
TDMBD1	Cobalt	T	Up	0.332362	2.993444
TDMBD1	Copper	F	Up	0.162264	1.814602
TDMBD1	Copper	T	No Trend	0.100609	1.418994
TDMBD1	Cyanide (amenable)	T	Up	0.400058	3.366907
TDMBD1	Cyanide (Free)	T	No Trend	0.115008	1.48634
TDMBD1	Cyanide Total	T	Down	0.170674	1.870447
TDMBD1	DO (Field)	T	Down	0.729122	3.281281
TDMBD1	EC (field)	T	No Trend	1.96E-02	0.583343
TDMBD1	Hardness as CaCO3	T	No Trend		
TDMBD1	Hydroxide	T	No Change	0	0
TDMBD1	Hydroxide as CaCO3	T	No Trend		
TDMBD1	Ionic Balance	T	No Trend	7.87E-03	0.267152
TDMBD1	Iron	F	Down	0.222534	2.205882
TDMBD1	Iron	T	No Trend	4.58E-02	0.929527
TDMBD1	Kjeldahl Nitrogen Total	F	No Trend	4.73E-02	0.77223
TDMBD1	Kjeldahl Nitrogen Total	T	No Trend	0.322927	1.544256
TDMBD1	Lead	F	Up	0.327035	2.874256
TDMBD1	Lead	T	No Trend	2.07E-02	0.617533
TDMBD1	Lithium	F	No Trend	0.163143	1.652048
TDMBD1	Magnesium	F	No Trend	0.173909	1.716768
TDMBD1	Magnesium	T	No Trend	7.61E-02	1.074231
TDMBD1	Manganese	F	Down	0.444467	3.687988
TDMBD1	Manganese	T	No Trend	6.16E-02	1.08679
TDMBD1	Mercury	F	No Trend	2.88E-11	9.29E-06
TDMBD1	Mercury	T	Up	0.310789	2.227169
TDMBD1	Molybdenum	F	Down	0.382087	2.942262
TDMBD1	Nickel	F	No Trend	0.12092	1.52918
TDMBD1	Nickel	T	Up	0.326374	2.953145
TDMBD1	Nitrate (as N)	F	Down	0.738269	7.125514
TDMBD1	Nitrate (as N)	T	No Trend		

Mt Todd Groundwater Trend Analysis 2011 -2019

TDMBD1	Nitrite (as N)	F	No Trend	9.51E-02	0.561449
TDMBD1	Nitrite (as N)	T	No Trend	5.18E-15	2.49E-07
TDMBD1	Nitrogen (Total)	T	Down	0.262342	2.458843
TDMBD1	pH (Field)	T	Up	0.262292	2.385122
TDMBD1	Phosphate total (as P)	T	No Trend	0.043419	0.301297
TDMBD1	Phosphorus	T	No Trend	1.18E-05	1.14E-02
TDMBD1	Potassium	F	No Trend	0.132164	1.460162
TDMBD1	Potassium	T	No Trend	0.154071	1.596828
TDMBD1	Selenium	F	No Trend	0.118794	1.373799
TDMBD1	Silver	F	Down	0.353228	2.765134
TDMBD1	Sodium	F	No Trend	1.19E-04	0.040807
TDMBD1	Sodium	T	No Trend	5.25E-02	0.880452
TDMBD1	Strontium	F	Down	0.767769	6.803287
TDMBD1	Sulphate	F	No Trend	0.233906	0.781438
TDMBD1	Sulphate	T	Down	0.691339	5.396053
TDMBD1	Sulphate as S	T	No Trend	0.290865	1.109283
TDMBD1	TDS	F	No Trend	0.115409	1.444805
TDMBD1	TDS	T	No Trend		
TDMBD1	Temp (Field)	T	Up	0.393863	3.224386
TDMBD1	Thallium	F	No Trend	0.118794	1.373799
TDMBD1	Thiocyanates (total)	T	No Trend		
TDMBD1	Thiocyanic Acid	T	Down	0.300187	2.36144
TDMBD1	Thiosulphate	T	No Trend		
TDMBD1	Thorium	F	Down	0.211591	1.867861
TDMBD1	Tin	F	Down	0.357333	2.79002
TDMBD1	Titanium	F	Down	0.508309	3.804362
TDMBD1	Uranium	F	Down	0.400537	3.058469
TDMBD1	Vanadium	F	Down	0.227209	2.028831
TDMBD1	Weak Acid Dissociable Cyanide	T	Down	0.276165	2.546764
TDMBD1	Zinc	F	Down	0.240521	2.320296
TDMBD1	Zinc	T	No Trend	9.57E-02	1.380376
TR_TW	EC (field)	T	No Trend		
TR_TW	pH (Field)	T	No Trend		
TR_TW	Temp (Field)	T	No Trend		
TSF2MB01	Alkalinity (Bicarbonate as CaCO3)	T	No Trend	0.232251	1.100017
TSF2MB01	Alkalinity (Bicarbonate)	T	No Trend	0.026403	0.329355
TSF2MB01	Alkalinity (Carbonate as CaCO3)	T	No Change	0	0
TSF2MB01	Alkalinity (Carbonate)	T	Down	0.840653	5.13596
TSF2MB01	Alkalinity (Hydroxide)	T	No Change	0	0
TSF2MB01	Alkalinity (total)	T	Down	1	999
TSF2MB01	Aluminium	F	Down	0.931854	7.395792
TSF2MB01	Aluminium	T	No Trend	0.333248	1.413943
TSF2MB01	Ammonia as N	F	No Trend		
TSF2MB01	Ammonia as N	T	No Trend	0.25	0.57735
TSF2MB01	Antimony	F	Down	0.931854	7.395792
TSF2MB01	Arsenic	F	No Trend	0.49829	1.993172
TSF2MB01	Arsenic	T	Up	0.560306	2.257706
TSF2MB01	Barium	F	No Trend	0.304949	1.324753
TSF2MB01	Beryllium	F	Down	0.931854	7.395792
TSF2MB01	Bismuth	F	Down	0.931854	7.395792
TSF2MB01	Boron	F	No Trend	0.320681	1.374135
TSF2MB01	Cadmium	F	Down	0.931854	7.395792
TSF2MB01	Cadmium	T	No Trend	3.23E-13	1.14E-06
TSF2MB01	Calcium	F	No Trend	5.26E-02	0.333333
TSF2MB01	Calcium	T	Up	0.663722	2.433352
TSF2MB01	Carbonate Alkalinity as CaCO3_	T	No Change	0	0

Mt Todd Groundwater Trend Analysis 2011 -2019

TSF2MB01	Chloride	T	Up	0.571746	2.310896
TSF2MB01	Chromium (III+VI)	F	No Change	0	0
TSF2MB01	Cobalt	F	Up	0.931854	7.395792
TSF2MB01	Cobalt	T	Up	0.841052	4.60059
TSF2MB01	Copper	F	No Change	0	0
TSF2MB01	Copper	T	No Trend	0.232251	1.100017
TSF2MB01	Cyanide (amenable)	T	Up	0.912749	6.468743
TSF2MB01	Cyanide (Free)	T	Down	0.912749	6.468743
TSF2MB01	Cyanide Total	T	Down	0.912749	6.468743
TSF2MB01	EC (field)	T	Up	0.899054	5.169036
TSF2MB01	Ionic Balance	T	No Trend	1.16E-02	0.108253
TSF2MB01	Iron	F	No Trend	0.241607	1.128852
TSF2MB01	Iron	T	No Trend	0.527011	2.111128
TSF2MB01	Kjeldahl Nitrogen Total	F	No Trend		
TSF2MB01	Kjeldahl Nitrogen Total	T	No Change	0	0
TSF2MB01	Lead	F	No Change	0	0
TSF2MB01	Lead	T	Up	0.636523	2.646661
TSF2MB01	Lithium	F	Up	0.693829	3.01075
TSF2MB01	Magnesium	F	No Trend	0.333333	1
TSF2MB01	Magnesium	T	Up	0.903961	5.313869
TSF2MB01	Manganese	F	Up	0.701244	3.064121
TSF2MB01	Manganese	T	Up	0.787022	3.844642
TSF2MB01	Mercury	F	No Change	0	0
TSF2MB01	Mercury	T	No Change	0	0
TSF2MB01	Molybdenum	F	Down	0.931854	7.395792
TSF2MB01	Nickel	F	Up	0.931854	7.395792
TSF2MB01	Nickel	T	Up	0.908965	6.31974
TSF2MB01	Nitrate (as N)	F	No Trend	0.479405	1.91925
TSF2MB01	Nitrite (as N)	F	No Trend	8.12E-11	9.01E-06
TSF2MB01	Nitrite (as N)	T	No Trend		
TSF2MB01	Nitrogen (Total)	T	Up	0.697564	3.037423
TSF2MB01	pH (Field)	T	No Trend	0.15529	0.742641
TSF2MB01	Phosphate total (as P)	T	Up	1	1470046
TSF2MB01	Phosphorus	T	No Trend		
TSF2MB01	Potassium	F	Down	1	1198086
TSF2MB01	Potassium	T	Up	0.902838	5.279797
TSF2MB01	Selenium	F	No Trend	0.150494	0.841793
TSF2MB01	Silver	F	Down	0.931854	7.395792
TSF2MB01	Sodium	F	No Change	0	0
TSF2MB01	Sodium	T	Up	0.741044	2.930012
TSF2MB01	Strontium	F	Up	0.83674	4.527776
TSF2MB01	Sulphate	T	Up	1	999
TSF2MB01	Sulphate as S	T	Down	1	999
TSF2MB01	TDS	F	Up	0.845808	4.056626
TSF2MB01	Temp (Field)	T	No Trend	6.91E-02	0.47204
TSF2MB01	Thallium	F	No Change	0	0
TSF2MB01	Thiocyanates (total)	T	No Trend		
TSF2MB01	Thiocyanic Acid	T	Down	0.984024	11.0989
TSF2MB01	Thorium	F	Down	0.931854	7.395792
TSF2MB01	Tin	F	Down	0.931854	7.395792
TSF2MB01	Titanium	F	Down	0.931854	7.395792
TSF2MB01	Uranium	F	Down	0.931854	7.395792
TSF2MB01	Vanadium	F	Down	0.931854	7.395792
TSF2MB01	Weak Acid Dissociable Cyanide	T	Down	0.912749	6.468743
TSF2MB01	Zinc	F	Up	0.827802	4.385092
TSF2MB01	Zinc	T	Up	0.859174	4.94002

Mt Todd Groundwater Trend Analysis 2011 -2019

TSF2MB02	Alkalinity (Bicarbonate as CaCO3)	T	Up	0.194551	1.838916
TSF2MB02	Alkalinity (Bicarbonate)	T	Up	0.241497	2.111257
TSF2MB02	Alkalinity (Carbonate as CaCO3)	T	No Change	0	0
TSF2MB02	Alkalinity (Carbonate)	T	Down	0.453313	3.526753
TSF2MB02	Alkalinity (Hydroxide)	T	No Change	0	0
TSF2MB02	Alkalinity (Hydroxide) as CaCO3	T	No Change	0	0
TSF2MB02	Alkalinity (total)	T	No Trend	0.493054	1.708153
TSF2MB02	Alkalinity (total) as CaCO3	T	Up	0.671723	3.784636
TSF2MB02	Aluminium	F	Down	0.378495	2.813709
TSF2MB02	Aluminium	T	No Trend	5.40E-02	0.894227
TSF2MB02	Ammonia as N	F	No Trend	8.14E-03	0.326606
TSF2MB02	Ammonia as N	T	No Trend		
TSF2MB02	Anions Total	T	No Trend		
TSF2MB02	Antimony	F	Down	0.389745	2.88142
TSF2MB02	Arsenic	F	No Trend	0.17328	1.650695
TSF2MB02	Arsenic	T	No Trend	1.19E-03	0.129003
TSF2MB02	Barium	F	Down	0.460498	3.33111
TSF2MB02	Beryllium	F	Down	0.378495	2.813709
TSF2MB02	Bismuth	F	Down	0.378495	2.813709
TSF2MB02	Boron	F	Down	0.283474	2.26784
TSF2MB02	Cadmium	F	Down	0.378495	2.813709
TSF2MB02	Cadmium	T	Down	0.340206	2.686775
TSF2MB02	Calcium	F	No Trend	1.82E-02	0.471063
TSF2MB02	Calcium	T	No Trend	2.45E-04	5.64E-02
TSF2MB02	Carbonate Alkalinity as CaCO3_	T	Down	0.997897	21.7807
TSF2MB02	Cations Total	T	No Trend		
TSF2MB02	Chloride	T	Down	0.316271	2.544789
TSF2MB02	Chromium (III+VI)	F	No Trend	5.48E-02	0.868461
TSF2MB02	Cobalt	F	No Change	0	0
TSF2MB02	Cobalt	T	No Trend	0.120807	1.386971
TSF2MB02	Copper	F	No Trend	2.78E-02	0.609739
TSF2MB02	Copper	T	No Trend	0.12493	1.413762
TSF2MB02	Cyanide (amenable)	T	Up	0.328943	2.619655
TSF2MB02	Cyanide (Free)	T	No Trend	1.31E-02	0.446867
TSF2MB02	Cyanide Total	T	No Trend	1.10E-02	0.40787
TSF2MB02	DO (Field)	T	No Trend	0.476333	1.907468
TSF2MB02	EC (field)	T	No Trend	4.16E-03	0.214437
TSF2MB02	Hardness as CaCO3	T	No Trend		
TSF2MB02	Hydroxide as CaCO3	T	No Trend		
TSF2MB02	Ionic Balance	T	No Trend	0.1153	1.197326
TSF2MB02	Iron	F	No Trend	2.04E-03	0.163101
TSF2MB02	Iron	T	No Trend	3.70E-03	0.227987
TSF2MB02	Kjeldahl Nitrogen Total	F	No Trend	8.30E-02	1.042187
TSF2MB02	Kjeldahl Nitrogen Total	T	No Change	0	0
TSF2MB02	Lead	F	No Trend	5.49E-03	0.267878
TSF2MB02	Lead	T	No Trend	3.17E-02	0.67645
TSF2MB02	Lithium	F	No Trend	0.103791	1.227004
TSF2MB02	Magnesium	F	No Trend	9.61E-03	0.341222
TSF2MB02	Magnesium	T	No Trend	3.66E-02	0.702378
TSF2MB02	Manganese	F	No Trend	3.55E-02	0.691775
TSF2MB02	Manganese	T	Down	0.315798	2.542003
TSF2MB02	Mercury	F	No Trend		
TSF2MB02	Mercury	T	No Trend	1.09E-14	3.46E-07
TSF2MB02	Molybdenum	F	Down	0.445201	3.229845
TSF2MB02	Nickel	F	No Trend	0.061578	0.923599
TSF2MB02	Nickel	T	No Trend	5.55E-03	0.279637

Mt Todd Groundwater Trend Analysis 2011 -2019

TSF2MB02	Nitrate (as N)	F	No Trend	3.60E-02	0.772888
TSF2MB02	Nitrite (as N)	F	Down	0.997897	21.7807
TSF2MB02	Nitrite (as N)	T	No Trend	4.90E-14	7.67E-07
TSF2MB02	Nitrogen (Total)	T	No Trend	3.54E-02	0.716404
TSF2MB02	pH (Field)	T	No Trend	0.14568	1.369577
TSF2MB02	Phosphate total (as P)	T	No Trend		
TSF2MB02	Phosphorus	T	No Change	0	0
TSF2MB02	Potassium	F	No Trend	0.109625	1.215512
TSF2MB02	Potassium	T	No Trend	0.150721	1.518913
TSF2MB02	Selenium	F	No Trend	4.13E-02	0.748613
TSF2MB02	Silver	F	Down	0.378495	2.813709
TSF2MB02	Sodium	F	No Trend	1.62E-02	0.444911
TSF2MB02	Sodium	T	No Trend	4.39E-02	0.772413
TSF2MB02	Strontium	F	No Trend	4.46E-02	0.779317
TSF2MB02	Sulphate	T	No Trend	3.80E-02	0.68848
TSF2MB02	Sulphate as S	T	No Trend		
TSF2MB02	TDS	F	No Trend	0.170641	1.697208
TSF2MB02	Temp (Field)	T	No Trend	0.111533	1.175108
TSF2MB02	Thallium	F	No Change	0	0
TSF2MB02	Thiocyanates (total)	T	No Trend		
TSF2MB02	Thiocyanic Acid	T	Down	0.249968	2.081487
TSF2MB02	Thorium	F	Down	0.378954	2.816455
TSF2MB02	Tin	F	Down	0.378495	2.813709
TSF2MB02	Titanium	F	Down	0.378495	2.813709
TSF2MB02	Uranium	F	Down	0.378495	2.813709
TSF2MB02	Vanadium	F	Down	0.378495	2.813709
TSF2MB02	Weak Acid Dissociable Cyanide	T	No Trend	1.31E-02	0.446867
TSF2MB02	Zinc	F	No Trend	2.34E-02	0.557929
TSF2MB02	Zinc	T	No Trend	6.55E-04	9.58E-02
TSFMB01	Alkalinity (Bicarbonate as CaCO3)	T	No Trend		
TSFMB01	Alkalinity (Bicarbonate)	T	No Trend		
TSFMB01	Alkalinity (Carbonate)	T	No Trend		
TSFMB01	Aluminium	F	No Trend		
TSFMB01	Aluminium	T	No Trend		
TSFMB01	Ammonia as N	T	No Trend		
TSFMB01	Antimony	F	No Trend		
TSFMB01	Arsenic	F	No Trend		
TSFMB01	Arsenic	T	No Trend		
TSFMB01	Barium	F	No Trend		
TSFMB01	Beryllium	F	No Trend		
TSFMB01	Bismuth	F	No Trend		
TSFMB01	Boron	F	No Trend		
TSFMB01	Cadmium	F	No Trend		
TSFMB01	Cadmium	T	No Trend		
TSFMB01	Calcium	T	No Trend		
TSFMB01	Carbonate Alkalinity as CaCO3_	T	No Trend		
TSFMB01	Chloride	T	No Trend		
TSFMB01	Chromium (III+VI)	F	No Trend		
TSFMB01	Cobalt	F	No Trend		
TSFMB01	Cobalt	T	No Trend		
TSFMB01	Copper	F	No Trend		
TSFMB01	Copper	T	No Trend		
TSFMB01	Cyanide (amenable)	T	No Trend		
TSFMB01	Cyanide (Free)	T	No Trend		
TSFMB01	Cyanide Total	T	No Trend		
TSFMB01	Iron	F	No Trend		

Mt Todd Groundwater Trend Analysis 2011 -2019

TSFMB01	Iron	T	No Trend		
TSFMB01	Kjeldahl Nitrogen Total	T	No Trend		
TSFMB01	Lead	F	No Trend		
TSFMB01	Lead	T	No Trend		
TSFMB01	Lithium	F	No Trend		
TSFMB01	Magnesium	T	No Trend		
TSFMB01	Manganese	F	No Trend		
TSFMB01	Manganese	T	No Trend		
TSFMB01	Mercury	F	No Trend		
TSFMB01	Molybdenum	F	No Trend		
TSFMB01	Nickel	F	No Trend		
TSFMB01	Nickel	T	No Trend		
TSFMB01	Nitrate (as N)	F	No Change	0	0
TSFMB01	Nitrite (as N)	F	No Trend		
TSFMB01	Nitrogen (Total)	T	No Trend		
TSFMB01	Phosphate total (as P)	T	No Trend		
TSFMB01	Potassium	T	No Trend		
TSFMB01	Selenium	F	No Trend		
TSFMB01	Silver	F	No Trend		
TSFMB01	Sodium	T	No Trend		
TSFMB01	Strontium	F	No Trend		
TSFMB01	Sulphate as S	T	No Trend		
TSFMB01	TDS	F	No Trend		
TSFMB01	Thallium	F	No Trend		
TSFMB01	Thorium	F	No Trend		
TSFMB01	Tin	F	No Trend		
TSFMB01	Titanium	F	No Trend		
TSFMB01	Uranium	F	No Trend		
TSFMB01	Vanadium	F	No Trend		
TSFMB01	Weak Acid Dissociable Cyanide	T	No Trend		
TSFMB01	Zinc	F	No Trend		
TSFMB01	Zinc	T	No Trend		
TSFMB02	Alkalinity (Bicarbonate as CaCO3)	T	No Trend		
TSFMB02	Alkalinity (Bicarbonate)	T	No Trend		
TSFMB02	Alkalinity (Carbonate)	T	No Trend		
TSFMB02	Aluminium	F	No Trend		
TSFMB02	Aluminium	T	No Trend		
TSFMB02	Ammonia as N	T	No Trend		
TSFMB02	Antimony	F	No Trend		
TSFMB02	Arsenic	F	No Trend		
TSFMB02	Arsenic	T	No Trend		
TSFMB02	Barium	F	No Trend		
TSFMB02	Beryllium	F	No Trend		
TSFMB02	Bismuth	F	No Trend		
TSFMB02	Boron	F	No Trend		
TSFMB02	Cadmium	F	No Trend		
TSFMB02	Cadmium	T	No Trend		
TSFMB02	Calcium	T	No Trend		
TSFMB02	Carbonate Alkalinity as CaCO3_	T	No Trend		
TSFMB02	Chloride	T	No Trend		
TSFMB02	Chromium (III+VI)	F	No Trend		
TSFMB02	Cobalt	F	No Trend		
TSFMB02	Cobalt	T	No Trend		
TSFMB02	Copper	F	No Trend		
TSFMB02	Copper	T	No Trend		
TSFMB02	Cyanide (amenable)	T	No Trend		

Mt Todd Groundwater Trend Analysis 2011 -2019

TSFMB02	Cyanide (Free)	T	No Trend		
TSFMB02	Cyanide Total	T	No Trend		
TSFMB02	Iron	F	No Trend		
TSFMB02	Iron	T	No Trend		
TSFMB02	Kjeldahl Nitrogen Total	T	No Trend		
TSFMB02	Lead	F	No Trend		
TSFMB02	Lead	T	No Trend		
TSFMB02	Lithium	F	No Trend		
TSFMB02	Magnesium	T	No Trend		
TSFMB02	Manganese	F	No Trend		
TSFMB02	Manganese	T	No Trend		
TSFMB02	Mercury	F	No Trend		
TSFMB02	Molybdenum	F	No Trend		
TSFMB02	Nickel	F	No Trend		
TSFMB02	Nickel	T	No Trend		
TSFMB02	Nitrate (as N)	F	No Change	0	0
TSFMB02	Nitrite (as N)	F	No Trend		
TSFMB02	Nitrogen (Total)	T	No Trend		
TSFMB02	Phosphate total (as P)	T	No Trend		
TSFMB02	Potassium	T	No Trend		
TSFMB02	Selenium	F	No Trend		
TSFMB02	Silver	F	No Trend		
TSFMB02	Sodium	T	No Trend		
TSFMB02	Strontium	F	No Trend		
TSFMB02	Sulphate as S	T	No Trend		
TSFMB02	TDS	F	No Trend		
TSFMB02	Thallium	F	No Trend		
TSFMB02	Thorium	F	No Trend		
TSFMB02	Tin	F	No Trend		
TSFMB02	Titanium	F	No Trend		
TSFMB02	Uranium	F	No Trend		
TSFMB02	Vanadium	F	No Trend		
TSFMB02	Weak Acid Dissociable Cyanide	T	No Trend		
TSFMB02	Zinc	F	No Trend		
TSFMB02	Zinc	T	No Trend		
WDMB01	Alkalinity (Bicarbonate as CaCO3)	T	Down	0.759938	3.08168
WDMB01	Alkalinity (Bicarbonate)	T	Down	0.73026	2.849883
WDMB01	Alkalinity (Carbonate as CaCO3)	T	No Trend		
WDMB01	Alkalinity (Carbonate)	T	Down	0.860782	4.97311
WDMB01	Alkalinity (Hydroxide)	T	No Trend		
WDMB01	Alkalinity (total)	T	No Trend		
WDMB01	Aluminium	F	Down	0.91046	6.377533
WDMB01	Aluminium	T	No Trend	0.388731	1.38124
WDMB01	Ammonia as N	F	No Trend		
WDMB01	Ammonia as N	T	No Trend	0.137741	0.565233
WDMB01	Antimony	F	Down	0.91046	6.377533
WDMB01	Arsenic	F	No Trend	0.215117	1.047043
WDMB01	Arsenic	T	No Trend	0.138865	0.69554
WDMB01	Barium	F	Up	0.962746	10.16709
WDMB01	Beryllium	F	Down	0.91046	6.377533
WDMB01	Bismuth	F	Down	0.91046	6.377533
WDMB01	Boron	F	Down	0.676986	2.895405
WDMB01	Cadmium	F	Down	0.91046	6.377533
WDMB01	Cadmium	T	Down	0.917144	5.762588
WDMB01	Calcium	F	No Trend		
WDMB01	Calcium	T	Up	0.970216	9.885665

Mt Todd Groundwater Trend Analysis 2011 -2019

WDMB01	Carbonate Alkalinity as CaCO3_	T	No Change	0	0
WDMB01	Chloride	T	Up	0.976813	11.24194
WDMB01	Chromium (III+VI)	F	No Change	0	0
WDMB01	Cobalt	F	Down	0.602313	2.461335
WDMB01	Cobalt	T	No Trend	2.68E-04	2.83E-02
WDMB01	Copper	F	No Change	0	0
WDMB01	Copper	T	No Trend	0.582752	2.04694
WDMB01	Cyanide (amenable)	T	Up	0.918464	4.746492
WDMB01	Cyanide (Free)	T	Down	0.918464	4.746492
WDMB01	Cyanide Total	T	Down	0.918464	4.746492
WDMB01	EC (field)	T	Up	0.996176	27.95425
WDMB01	Ionic Balance	T	No Trend		
WDMB01	Iron	F	Up	0.954453	9.155406
WDMB01	Iron	T	Up	0.724059	2.805687
WDMB01	Kjeldahl Nitrogen Total	F	No Trend		
WDMB01	Kjeldahl Nitrogen Total	T	No Change	0	0
WDMB01	Lead	F	No Change	0	0
WDMB01	Lead	T	No Trend	7.81E-04	4.84E-02
WDMB01	Lithium	F	Up	0.569297	2.299379
WDMB01	Magnesium	F	No Trend		
WDMB01	Magnesium	T	Up	0.980296	12.2169
WDMB01	Manganese	F	Up	0.974608	12.39084
WDMB01	Manganese	T	Up	0.901492	5.23968
WDMB01	Mercury	F	No Change	0	0
WDMB01	Mercury	T	No Trend		
WDMB01	Molybdenum	F	Down	0.91046	6.377533
WDMB01	Nickel	F	No Trend	0.223193	1.072046
WDMB01	Nickel	T	Up	0.941388	6.941476
WDMB01	Nitrate (as N)	F	No Trend	0.076602	0.762034
WDMB01	Nitrite (as N)	F	No Trend	0.75	1.732051
WDMB01	Nitrite (as N)	T	No Trend		
WDMB01	Nitrogen (Total)	T	No Trend	0.353767	1.281518
WDMB01	pH (Field)	T	No Trend	0.614987	2.18905
WDMB01	Phosphate total (as P)	T	Down	0.99937	39.83717
WDMB01	Phosphorus	T	No Trend		
WDMB01	Potassium	F	No Trend		
WDMB01	Potassium	T	Up	0.738506	2.910763
WDMB01	Selenium	F	No Change	0	0
WDMB01	Silver	F	Down	0.91046	6.377533
WDMB01	Sodium	F	No Trend		
WDMB01	Sodium	T	Up	0.85944	4.282898
WDMB01	Strontium	F	Up	0.987253	17.60104
WDMB01	Sulphate	T	No Trend		
WDMB01	Sulphate as S	T	No Trend	0.667725	2.004773
WDMB01	TDS	F	Up	0.984623	13.86001
WDMB01	Temp (Field)	T	No Trend	0.527376	1.829629
WDMB01	Thallium	F	No Change	0	0
WDMB01	Thiocyanates (total)	T	No Trend		
WDMB01	Thiocyanic Acid	T	Down	0.987067	8.736388
WDMB01	Thorium	F	No Trend	0.32742	1.395438
WDMB01	Tin	F	Down	0.91046	6.377533
WDMB01	Titanium	F	Down	0.91046	6.377533
WDMB01	Uranium	F	Down	0.91046	6.377533
WDMB01	Vanadium	F	Down	0.91046	6.377533
WDMB01	Weak Acid Dissociable Cyanide	T	Down	0.918464	4.746492
WDMB01	Zinc	F	No Trend	0.136733	0.795964

Mt Todd Groundwater Trend Analysis 2011 -2019

WDMB01	Zinc	T	No Trend	2.52E-03	8.71E-02
WDMB02	Alkalinity (Bicarbonate as CaCO3)	T	No Trend	0.146276	1.548788
WDMB02	Alkalinity (Bicarbonate)	T	No Trend	0.131832	1.458052
WDMB02	Alkalinity (Carbonate as CaCO3)	T	No Change	0	0
WDMB02	Alkalinity (Carbonate)	T	Down	0.577028	4.523644
WDMB02	Alkalinity (Hydroxide)	T	No Change	0	0
WDMB02	Alkalinity (Hydroxide) as CaCO3	T	No Change	0	0
WDMB02	Alkalinity (total)	T	No Trend	0.761609	2.527765
WDMB02	Alkalinity (total) as CaCO3	T	No Trend	4.05E-05	0.016847
WDMB02	Aluminium	F	Down	0.533455	3.85544
WDMB02	Aluminium	T	No Trend	0.17705	1.672373
WDMB02	Ammonia as N	F	No Trend	1.50E-02	0.408877
WDMB02	Ammonia as N	T	No Trend	9.09E-02	0.447214
WDMB02	Anions Total	T	No Trend		
WDMB02	Antimony	F	Down	0.533455	3.85544
WDMB02	Arsenic	F	No Trend	0.148089	1.503264
WDMB02	Arsenic	T	No Trend	8.47E-02	1.096929
WDMB02	Barium	F	Up	0.600863	4.423834
WDMB02	Beryllium	F	Down	0.533455	3.85544
WDMB02	Bismuth	F	Down	0.533455	3.85544
WDMB02	Boron	F	Down	0.458927	3.320594
WDMB02	Cadmium	F	Down	0.533455	3.85544
WDMB02	Cadmium	T	Down	0.533455	3.85544
WDMB02	Calcium	F	Up	0.872448	8.674043
WDMB02	Calcium	T	Up	0.863408	9.064996
WDMB02	Carbonate Alkalinity as CaCO3_	T	Down	0.992945	16.77805
WDMB02	Cations Total	T	No Trend		
WDMB02	Chloride	T	Down	0.366223	2.844255
WDMB02	Chromium (III+VI)	F	No Change	0	0
WDMB02	Cobalt	F	No Trend	1.11E-02	0.382142
WDMB02	Cobalt	T	No Change	0	0
WDMB02	Copper	F	No Trend	0.151201	1.52176
WDMB02	Copper	T	No Trend	0.138617	1.446377
WDMB02	Cyanide (amenable)	T	Up	0.540082	4.054656
WDMB02	Cyanide (Free)	T	No Trend	2.16E-04	5.50E-02
WDMB02	Cyanide Total	T	No Trend	4.05E-04	7.53E-02
WDMB02	DO (Field)	T	Down	0.682401	2.931635
WDMB02	EC (field)	T	Up	0.450965	3.139514
WDMB02	Hardness as CaCO3	T	No Trend		
WDMB02	Hydroxide as CaCO3	T	No Trend		
WDMB02	Ionic Balance	T	No Trend	0.142998	1.291739
WDMB02	Iron	F	Up	0.746686	6.190293
WDMB02	Iron	T	No Trend	1.95E-02	0.508552
WDMB02	Kjeldahl Nitrogen Total	F	No Trend	3.40E-02	0.622333
WDMB02	Kjeldahl Nitrogen Total	T	No Trend	1.51E-26	2.13E-13
WDMB02	Lead	F	No Change	0	0
WDMB02	Lead	T	Down	0.477749	3.448513
WDMB02	Lithium	F	Up	0.728519	5.906401
WDMB02	Magnesium	F	Up	0.886525	9.270238
WDMB02	Magnesium	T	Up	0.863316	9.061456
WDMB02	Manganese	F	Up	0.904224	11.07848
WDMB02	Manganese	T	Up	0.745114	6.164675
WDMB02	Mercury	F	No Change	0	0
WDMB02	Mercury	T	No Trend	1.65E-13	1.28E-06
WDMB02	Molybdenum	F	Down	0.533455	3.85544
WDMB02	Nickel	F	No Trend	2.51E-02	0.578002

Mt Todd Groundwater Trend Analysis 2011 -2019

WDMB02	Nickel	T	No Trend	7.95E-04	0.101709
WDMB02	Nitrate (as N)	F	No Trend	0.125764	1.563827
WDMB02	Nitrite (as N)	F	No Trend	0.186183	0.676427
WDMB02	Nitrite (as N)	T	No Trend	3.05E-13	1.75E-06
WDMB02	Nitrogen (Total)	T	No Trend	2.17E-02	0.55699
WDMB02	pH (Field)	T	No Trend	6.83E-02	0.938076
WDMB02	Phosphate total (as P)	T	No Trend	0.107143	0.34641
WDMB02	Phosphorus	T	Down	0.337439	2.366907
WDMB02	Potassium	F	Up	0.352659	2.447977
WDMB02	Potassium	T	Up	0.662578	5.052468
WDMB02	Selenium	F	No Change	0	0
WDMB02	Silver	F	Down	0.533455	3.85544
WDMB02	Sodium	F	No Trend	0.190058	1.606619
WDMB02	Sodium	T	Up	0.530273	3.830884
WDMB02	Strontium	F	Up	0.960202	17.71006
WDMB02	Sulphate	T	No Trend	0.175176	1.528454
WDMB02	Sulphate as S	T	Up	0.911886	4.549479
WDMB02	TDS	F	Up	0.579874	4.550115
WDMB02	Temp (Field)	T	No Trend	3.21E-02	0.631269
WDMB02	Thallium	F	No Change	0	0
WDMB02	Thiocyanates (total)	T	No Trend		
WDMB02	Thiocyanic Acid	T	No Trend	0.16032	1.513656
WDMB02	Thorium	F	Down	0.306592	2.397493
WDMB02	Tin	F	Down	0.533455	3.85544
WDMB02	Titanium	F	Down	0.533455	3.85544
WDMB02	Uranium	F	Down	0.533455	3.85544
WDMB02	Vanadium	F	Down	0.533455	3.85544
WDMB02	Weak Acid Dissociable Cyanide	T	No Trend	2.16E-04	5.50E-02
WDMB02	Zinc	F	No Trend	0.105026	1.235138
WDMB02	Zinc	T	No Trend	0.127652	1.379245

Field		Cyanides										Metals																	
EC (field)	Temp (Field)	Weak Acid Dissociable Cyanide	Thiocyanic Acid	Antimony (Filtered)	Bismuth (Filtered)	Lithium (Filtered)	Strontium (Filtered)	Thallium (Filtered)	Titanium (Filtered)	Uranium (Filtered)	Arsenic	Arsenic (Filtered)	Barium (Filtered)	Beryllium (Filtered)	Boron (Filtered)	Cadmium	Cadmium (Filtered)	Chromium (III+VI) (Filtered)	Cobalt	Cobalt (Filtered)	Copper	Copper (Filtered)	Phosphorus	Calcium	Calcium (Filtered)	Magnesium	Magnesium (Filtered)	Molybdenum (Filtered)	Potassium
uS/cm	°C	mg/L	mg/L	µg/L	µg/L	µg/L	µg/L	µg/L	µg/L	µg/L	µg/L	µg/L	µg/L	µg/L	µg/L	µg/L	µg/L	µg/L	µg/L	µg/L	µg/L	µg/L	µg/L	mg/L	mg/L	mg/L	mg/L	mg/L	mg/L
EQL		0.004	0.1	1	1	1	1	1	1	0.5	1	1	1	0.5	5	0.1	0.1	1	1	1	1	1	50	0.5	0.5	0.5	0.5	1	0.5

Location Code Sampled Date Time

BW29	23-Apr-2013	91.9	29.46	-	-	-	-	-	-	-	-	-	-	-	-	-	-	-	-	-	-	-	-	-	-	-	-	-	-	-	
BW29	04-Dec-2013	-	-	<0.004	<0.1	1	<1	14	39	<1	<1	<0.5	260	220	38	<0.5	14	<0.1	<0.1	<1	15	12	2	<1	500	6.6	5.8	11	9.3	20	2.1

Statistical Summary

Number of Results	1	1	1	1	1	1	1	1	1	1	1	1	1	1	1	1	1	1	1	1	1	1	1	1	1	1	1	1	1	1
Number of Detects	1	1	0	0	1	0	1	1	0	0	0	1	1	1	0	1	0	0	0	1	1	1	0	1	1	1	1	1	1	1
Minimum Concentration	91.9	29.46	<0.004	<0.1	1	<1	14	39	<1	<1	<0.5	260	220	38	<0.5	14	<0.1	<0.1	<1	15	12	2	<1	500	6.6	5.8	11	9.3	20	2.1
Maximum Concentration	91.9	29.46	<0.004	<0.1	1	<1	14	39	<1	<1	<0.5	260	220	38	<0.5	14	<0.1	<0.1	<1	15	12	2	<1	500	6.6	5.8	11	9.3	20	2.1
Median Concentration	91.9	29.46	0.002	0.05	1	0.5	14	39	0.5	0.5	0.25	260	220	38	0.25	14	0.05	0.05	0.5	15	12	2	0.5	500	6.6	5.8	11	9.3	20	2.1
Standard Deviation																														

	Potassium (Filtered)	Silver (Filtered)	Tin (Filtered)	Aluminium	Aluminium (Filtered)	Iron	Iron (Filtered)	Lead	Lead (Filtered)	Manganese	Manganese (Filtered)	Mercury	Nickel	Nickel (Filtered)	Selenium (Filtered)	Zinc	Zinc (Filtered)	Vanadium (Filtered)	Alkalinity (Bicarbonate)	Alkalinity (Carbonate)	Alkalinity (Hydroxide)	Alkalinity (total)	Cyanide (amenable)	Ionic Balance	Thorium (Filtered)	Cyanide (Free)	pH (Field)	Alkalinity (Bicarbonate as CaCO3)	Nitrogen (Total)	Alkalinity (Carbonate as CaCO3)
	mg/L	µg/L	µg/L	µg/L	µg/L	mg/L	mg/L	µg/L	µg/L	µg/L	µg/L	µg/L	µg/L	µg/L	µg/L	µg/L	µg/L	µg/L	mg/L	mg/L	mg/L	mg/L	mg/L	%	µg/L	mg/L	pH_Unit	mg/L	µg/L	mg/L
EQL	0.5	1	1	10	10	0.01	0.01	1	1	5	5	0.05	1	1	1	1	1	1			5	5	0.1		0.5	0.004		5	100	5

Location Code Sampled Date Time

BW29	23-Apr-2013	-	-	-	-	-	-	-	-	-	-	-	-	-	-	-	-	-	-	-	-	-	-	-	-	-	5.96	-	-	-	
BW29	04-Dec-2013	1.8	<1	<1	40	<10	3.6	3	<1	<1	940	760	<0.05	4	3	<1	5	4	<1	84.18	3	<5	69	<0.1	-4.8	<0.5	<0.004	-	69	600	<5

Statistical Summary

Number of Results	1	1	1	1	1	1	1	1	1	1	1	1	1	1	1	1	1	1	1	1	1	1	1	1	1	1	1	1	1	1	1
Number of Detects	1	0	0	1	0	1	1	0	0	1	1	0	1	1	0	1	1	0	1	1	0	1	0	1	0	0	1	1	1	0	
Minimum Concentration	1.8	<1	<1	40	<10	3.6	3	<1	<1	940	760	<0.05	4	3	<1	5	4	<1	84.18	3	<5	69	<0.1	-4.8	<0.5	<0.004	5.96	69	600	<5	
Maximum Concentration	1.8	<1	<1	40	<10	3.6	3	<1	<1	940	760	<0.05	4	3	<1	5	4	<1	84.18	3	<5	69	<0.1	0	<0.5	<0.004	5.96	69	600	<5	
Median Concentration	1.8	0.5	0.5	40	5	3.6	3	0.5	0.5	940	760	0.025	4	3	0.5	5	4	0.5	84.18	3	2.5	69	0.05	-4.8	0.25	0.002	5.96	69	600	2.5	
Standard Deviation																															

	Cyanide Total	Sodium	Sodium (Filtered)	Sulphate	TDS (Filtered)	Chloride	Ammonia as N (Filtered)	Nitrate (as N) (Filtered)	Nitrite (as N)	Kjeldahl Nitrogen Total (Filtered)
	mg/L	mg/L	mg/L	mg/L	mg/L	mg/L	mg/L	mg/L	mg/L	mg/L
EQL	0.004	0.5	0.5	1	5	1	0.005	0.005	0.005	0.1

Location Code Sampled Date Time

BW29	23-Apr-2013	-	-	-	-	-	-	-	-	-	
BW29	04-Dec-2013	<0.004	12	9.6	3	120	8	0.047	<0.005	<0.005	0.6

Statistical Summary

Number of Results	1	1	1	1	1	1	1	1	1	1
Number of Detects	0	1	1	1	1	1	1	0	0	1
Minimum Concentration	<0.004	12	9.6	3	120	8	0.047	<0.005	<0.005	0.6
Maximum Concentration	<0.004	12	9.6	3	120	8	0.047	<0.005	<0.005	0.6
Median Concentration	0.002	12	9.6	3	120	8	0.047	0.0025	0.0025	0.6
Standard Deviation										

EQL	Field				Cyanides														Metals																											
	DO % Saturation (Field)	DO (Field)	EC (field)	Temp (Field)	Carbonate Alkalinity as CaCO3_	Thiocyanates (total)	Thiosulphate	Weak Acid Dissociable Cyanide	Thiocyanic Acid	Antimony (Filtered)	Bismuth (Filtered)	Lithium (Filtered)	Strontium (Filtered)	Thallium (Filtered)	Titanium (Filtered)	Uranium (Filtered)	Arsenic	Arsenic (Filtered)	Barium (Filtered)	Beryllium (Filtered)	Boron (Filtered)	Cadmium	Cadmium (Filtered)	Chromium (III+VI) (Filtered)	Cobalt	Cobalt (Filtered)	Copper	Copper (Filtered)	Phosphorus	Calcium	Calcium (Filtered)	Magnesium	Magnesium (Filtered)	Molybdenum (Filtered)	Potassium	Potassium (Filtered)	Silver (Filtered)	Tin (Filtered)	Aluminium	Aluminium (Filtered)	Iron	Iron (Filtered)	Lead	Lead (Filtered)		
%	mg/L	uS/cm	°C	mg/L	µg/L	mg/L	mg/L	mg/L	µg/L	µg/L	µg/L	µg/L	µg/L	µg/L	µg/L	µg/L	µg/L	µg/L	µg/L	µg/L	µg/L	µg/L	µg/L	µg/L	µg/L	µg/L	µg/L	µg/L	µg/L	µg/L	µg/L	µg/L	µg/L	µg/L	µg/L	µg/L	µg/L	µg/L	µg/L	µg/L	µg/L	µg/L	µg/L	µg/L	µg/L	µg/L
EQL					5	100		0.004	0.1	1	1	0.5	1	1	1	0.5	1	1	1	0.5	5	0.1	0.1	1	1	1	1	1	50	0.5	0.5	0.5	0.5	1	0.5	0.5	1	1	10	10	0.01	0.01	1	1		

Location Code Sampled Date Time

BW6P	01-May-2011	-	-	-	-	-	<0.1	<0.01	-	0.25	0.01	49	188	0.03	<2	0.36	25	17.5	88.6	0.05	28.5	<0.02	<0.02	<0.1	0.82	0.78	0.19	0.06	10	33.3	32.2	60.1	57.6	0.4	3.6	3.5	<0.05	<0.1	21.4	0.6	1.75	0.6	17.9	0.94				
BW6P	20-May-2011	-	-	872	32	-	-	-	-	-	-	-	-	-	-	-	-	-	-	-	-	-	-	-	-	-	-	-	-	-	-	-	-	-	-	-	-	-	-	-	-	-	-	-	-	-		
BW6P	01-Sep-2011	-	-	-	-	<10	-	<0.005	-	<5	<5	50	150	<1	<5	<5	16	17	80	<1	<50	<0.2	<0.2	<1	<1	<1	<1	1	-	22	-	45	-	<5	3	-	<5	<5	<50	<50	0.32	0.28	6	5				
BW6P	01-Sep-2011	-	-	-	-	<10	-	0.005	-	<5	<5	52	160	<1	<5	<5	15	16	80	<1	<50	<0.2	<0.2	<1	<1	<1	<1	1	-	30	-	58	-	<5	3.7	-	<5	<5	<50	<50	0.26	0.25	6	4				
BW6P	09-Sep-2011	-	-	845	32.5	-	-	-	-	-	-	-	-	-	-	-	-	-	-	-	-	-	-	-	-	-	-	-	-	-	-	-	-	-	-	-	-	-	-	-	-	-	-	-	-	-		
BW6P	01-Dec-2011	-	-	-	-	<10	-	<0.005	<0.5	<5	<5	38	150	<1	<5	<5	15	15	90	<1	<50	<0.2	<0.2	<1	<1	<1	1	<1	1	31	-	55	-	<5	3.1	-	<5	<5	<50	<50	0.47	0.42	5	4				
BW6P	16-Dec-2011	-	-	882	32	-	-	-	-	-	-	-	-	-	-	-	-	-	-	-	-	-	-	-	-	-	-	-	-	-	-	-	-	-	-	-	-	-	-	-	-	-	-	-	-	-		
BW6P	01-Mar-2012	-	-	-	-	-	-	-	-	-	-	-	-	-	-	-	-	-	-	-	-	-	-	-	-	-	-	-	-	-	-	-	-	-	-	-	-	-	-	-	-	-	-	-	-	-		
BW6P	01-Mar-2012	-	-	-	-	<10	-	<0.005	<0.5	<5	<5	36	170	<1	<5	<5	15	17	90	<1	<50	<0.2	<0.2	<1	<1	<1	1	<1	1	30	-	57	-	<5	3	-	<5	<5	<50	<50	0.63	0.44	8	2				
BW6P	17-Mar-2012	-	-	930	31.9	-	-	-	-	-	-	-	-	-	-	-	-	-	-	-	-	-	-	-	-	-	-	-	-	-	-	-	-	-	-	-	-	-	-	-	-	-	-	-	-	-		
BW6P	26-Apr-2013	-	-	-	-	-	-	-	-	-	-	-	-	-	-	-	-	-	-	-	-	-	-	-	-	-	-	-	-	-	-	-	-	-	-	-	-	-	-	-	-	-	-	-	-	-	-	
BW6P	26-Apr-2013	-	-	-	-	100	-	<0.004	-	<1	<1	43	190	<1	<1	<0.5	17	16	88	<0.5	10	<0.1	<0.1	<1	1	<1	1	<1	<50	40	39	72	69	<1	4.1	4.2	<1	<1	17	<10	0.51	0.46	4	2				
BW6P	26-Apr-2013	-	-	1018	34.73	-	-	-	-	-	-	-	-	-	-	-	-	-	-	-	-	-	-	-	-	-	-	-	-	-	-	-	-	-	-	-	-	-	-	-	-	-	-	-	-	-	-	
BW6P	06-Dec-2013	-	-	-	-	-	-	<0.004	<0.1	<1	<1	52	180	<1	<1	<0.5	16	15	85	<0.5	23	<0.1	<0.1	<1	<1	<1	<1	<50	39	35	69	63	<1	3.9	3.7	<1	<1	<10	<10	0.55	0.52	8	5					
BW6P	19-Aug-2015	-	-	-	-	-	-	<0.004	<0.1	<1	<1	48	210	<1	<1	<0.5	10	11	77	<0.5	22	<0.1	<0.1	<1	<1	<1	<1	<50	47	44	81	75	<1	5.1	4.5	<1	<1	<10	<10	0.4	0.48	6	3					
BW6P	19-Aug-2015	-	-	1109.9	29.2	-	-	-	-	-	-	-	-	-	-	-	-	-	-	-	-	-	-	-	-	-	-	-	-	-	-	-	-	-	-	-	-	-	-	-	-	-	-	-	-	-	-	
BW6P	16-Feb-2016	-	-	-	-	-	-	<0.004	<0.1	<1	<1	46	240	<1	<1	<0.5	18	18	77	<0.5	25	<0.1	<0.1	<1	<1	<1	<1	<50	46	49	75	83	<1	4.2	4.1	<1	<1	<10	<10	0.9	0.75	7	3					
BW6P	17-Feb-2016	-	-	1165	32.1	-	-	-	-	-	-	-	-	-	-	-	-	-	-	-	-	-	-	-	-	-	-	-	-	-	-	-	-	-	-	-	-	-	-	-	-	-	-	-	-	-	-	
BW6P	28-Sep-2016	-	-	-	-	<5	-	<0.004	<0.5	<1	<1	50	230	<1	<1	<0.5	19	20	87	<0.5	27	<0.1	<0.1	<1	<1	<1	<1	<50	44	46	75	79	<1	3.9	4	<1	<1	<10	<10	0.73	0.59	8	3					
BW6P	28-Sep-2016	91.6	-	1104	30.4	-	-	-	-	-	-	-	-	-	-	-	-	-	-	-	-	-	-	-	-	-	-	-	-	-	-	-	-	-	-	-	-	-	-	-	-	-	-	-	-	-	-	
BW6P	29-Mar-2017	-	-	-	-	-	-	<0.004	<0.1	<1	<1	54	260	<1	<1	<0.5	21	20	62	<0.5	20	<0.1	<0.1	<1	<1	<1	<1	<50	56	54	88	85	<1	4.5	4.7	<1	<1	<10	<10	1.4	1.4	6	<1					
BW6P	05-Apr-2017	-	-	-	-	-	-	<0.004	0.1	-	-	-	-	-	-	-	-	-	-	-	-	-	-	-	-	-	<50	-	49	-	83	-	-	-	-	-	-	-	-	-	-	-	-	-	-	-	-	-
BW6P	05-Apr-2017	-	-	1210	32.3	-	-	-	-	-	-	-	-	-	-	-	-	-	-	-	-	-	-	-	-	-	-	-	-	-	-	-	-	-	-	-	-	-	-	-	-	-	-	-	-	-	-	-
BW6P	29-Sep-2017	-	-	-	-	-	-	<0.004	0.2	<1	<1	51	270	<1	<1	<0.5	20	20	65	<0.5	<20	<0.1	<0.1	<1	<1	<1	<1	<50	52	51	84	85	<1	4.9	5	<1	<1	<10	<10	1.2	1.2	9	<1					
BW6P	29-Sep-2017	-	5.63	1220	33.58	-	-	-	-	-	-	-	-	-	-	-	-	-	-	-	-	-	-	-	-	-	-	-	-	-	-	-	-	-	-	-	-	-	-	-	-	-	-	-	-	-	-	-
BW6P	29-Mar-2018	-	5.48	1232	32.5	-	-	-	-	-	-	-	-	-	-	-	-	-	-	-	-	-	-	-	-	-	-	-	-	-	-	-	-	-	-	-	-	-	-	-	-	-	-	-	-	-	-	-
BW6P	05-Oct-2018	-	-	-	-	-	-	<0.004	<0.1	<1	<1	55	260	<1	<1	<0.5	18	17	65	<0.5	<20	<0.1	<0.1	<1	<1	<1	<1	<50	51	49	84	79	<1	4.5	4.3	<1	<1	<10	<10	1.1	1.1	11	5					
BW6P	05-Oct-2018	-	5.82	1136	32.6	-	-	-	-	-	-	-	-	-	-	-	-	-	-	-	-	-	-	-	-	-	-	-	-	-	-	-	-	-	-	-	-	-	-	-	-	-	-	-	-	-	-	-
BW6P	01-May-2019	-	-	-	-	-	-	<0.004	0.2	<1	<1	53	230	<1	<1	<0.5	26	23	60	<0.5	30	<0.1	<0.1	<1	<1	<1	<1	<50	47	46	82	80	<1	4.5	4.5	<1	<1	10	<10	1.1	1.1	9	<1					
BW6P	01-May-2019	-	3.4	1155	32.3	-	-	-	-	-	-	-	-	-	-	-	-	-	-	-	-	-	-	-	-	-	-	-	-	-	-	-	-	-	-	-	-	-	-	-	-	-	-	-	-	-	-	-

Statistical Summary

Number of Results	1	4	13	13	5	1	1	15	11	14	14	14	14	14	14	14	14	14	14	14	14	14	14	14	14	14	11	14	11	14	11	14	14	11	14	14	14	14	14	14	14	14	14	14	14	14	14	14
Number of Detects	1	4	13	13	0	1	0	1	3	1	1	14	14	1	0	1	14	14	14	1	8	0	0	0	2	1	4	3	1	14	11	14	11	1	14	11	0	0	3	1	14	14	14	14	11	11	11	11
Minimum Concentration	91.6	3.4	845	29.2	<5	100	<0.1	<0.004	<0.1	0.25	0.01	36	150	0.03	<1	0.36	10	11	60	0.05	10	<0.02	<0.02	<0.1	0.82	0.78	0.19	0.06	10	22	32.2	45	57.6	0.4	3	3.5	<0.05	<0.1	<10	0.6	0.26	0.25	4	0.94				
Maximum Concentration	91.6	5.82	1232	34.73	<10	100	<0.1	<0.01	<0.5	<5	<5	55	270	<1	<5	<5	26	23	90	<1	<50	<0.2	<0.2	<1	1	<1	1	1	<50	56	54	88	85	<5	5.1	5	<5	<5	<50	<50	1.75	1.4	17.9	5				
Median Concentration	91.6	5.555	1110	32.3	5	100	0.05	0.002	0.1	0.5	0.5	50	200	0.5	0.5	0.25	17.5	17	80	0.25	25	0.05	0.05																									

EQL											Inorganics																																		
	Manganese	Manganese (Filtered)	Mercury	Mercury (Filtered)	Nickel	Nickel (Filtered)	Selenium (Filtered)	Zinc	Zinc (Filtered)	Vanadium (Filtered)	Alkalinity (Bicarbonate)	Alkalinity (Carbonate)	Alkalinity (Hydroxide)	Alkalinity (total)	Anions Total	Cations Total	Cyanide (amenable)	Hydroxide	Hydroxide as CaCO3	Ionic Balance	Silica	Sulphate as S	Thorium (Filtered)	Cyanide (Free)	pH (Field)	Alkalinity (Bicarbonate as CaCO3)	Nitrogen (Total)	Alkalinity (Carbonate as CaCO3)	Alkalinity (Hydroxide) as CaCO3	Alkalinity (total) as CaCO3	Phosphate total (as P)	Cyanide Total	Hardness as CaCO3	Sodium	Sodium (Filtered)	Sulphate	Sulphate (Filtered)	TDS	TDS (Filtered)	Chloride	Ammonia as N				
5	5	0.05	1	1	1	1	1	1	1	267	<1	5	5	0	0	0.005		5		%	µg/L	mg/L	µg/L	mg/L	pH_Unit	mg/L	µg/L	mg/L	mg/L	mg/L	MG/L	mg/L	mg/L	mg/L	mg/L	mg/L	mg/L	mg/L	mg/L	mg/L	mg/L	mg/L	mg/L	mg/L	mg/L

Location Code	Sampled Date Time	294	316	<0.02	-	0.06	0.07	<0.2	2.3	1.6	<0.05	267	<1	-	267	9.12	9.91	<0.1	<1000	-	4.2	-	-	<0.01	<1	-	-	20	-	-	-	-	<0.01	-	81.9	79.9	207	198	560	-	22.2	0.01		
BW6P	01-May-2011	294	316	<0.02	-	0.06	0.07	<0.2	2.3	1.6	<0.05	267	<1	-	267	9.12	9.91	<0.1	<1000	-	4.2	-	-	<0.01	<1	-	-	20	-	-	-	-	<0.01	-	81.9	79.9	207	198	560	-	22.2	0.01		
BW6P	20-May-2011	-	-	-	-	-	-	-	-	-	-	-	-	-	-	-	-	-	-	-	-	-	-	-	6.52	-	-	-	-	-	-	-	-	-	-	-	-	-	-	-	-	-	-	-
BW6P	01-Sep-2011	210	210	<0.1	<1	<1	<1	40	12	<5	341.6	6	-	-	-	-	-	<0.005	-	-	-	62-63	<5	<0.005	-	280	360	-	-	-	<0.05	<0.005	-	72	-	-	-	-	-	-	480	23	<0.01-0.04	
BW6P	01-Sep-2011	210	220	<0.1	<1	<1	<1	44	6	<5	341.6	6	-	-	-	-	-	0.0007	-	-	-	19,000	71	<5	<0.005	-	280	340	-	-	-	0.08	0.009	-	81	-	-	-	-	-	520	23	<0.01	
BW6P	09-Sep-2011	-	-	-	-	-	-	-	-	-	-	-	-	-	-	-	-	-	-	-	-	-	-	-	6.33	-	-	-	-	-	-	-	-	-	-	-	-	-	-	-	-	-	-	-
BW6P	01-Dec-2011	190	190	<0.1	<1	<1	<1	3	2	<5	340	<10-6	-	-	-	-	-	<0.005	-	-	-	60	<1000	<0.005	-	280	<200	-	-	-	<0.05	<0.005	-	79	-	-	-	-	-	-	680	23	<0.01	
BW6P	16-Dec-2011	-	-	-	-	-	-	-	-	-	-	-	-	-	-	-	-	-	-	-	-	-	-	-	6.46	-	-	-	-	-	-	-	-	-	-	-	-	-	-	-	-	-	-	
BW6P	01-Mar-2012	-	-	-	-	-	-	-	-	-	-	-	-	-	-	-	-	-	-	-	-	-	-	-	-	-	-	-	-	-	-	-	-	-	-	-	-	-	-	-	-	-	-	
BW6P	01-Mar-2012	230	270	<0.1	<1	<1	<1	3	5	<5	317.2	6	-	-	-	-	-	<0.005	-	-	-	75	<1000	<0.005	-	260	<200	-	-	-	0.06	<0.005	-	76	-	-	-	-	-	550	22	<0.2		
BW6P	17-Mar-2012	-	-	-	-	-	-	-	-	-	-	-	-	-	-	-	-	-	-	-	-	-	-	-	6.35	-	-	-	-	-	-	-	-	-	-	-	-	-	-	-	-	-	-	-
BW6P	26-Apr-2013	-	-	<0.05	-	-	-	-	-	-	-	-	-	-	-	-	-	-	-	-	-	-	-	-	-	-	-	-	-	-	-	-	-	-	-	-	-	-	-	-	-	-	-	
BW6P	26-Apr-2013	360	350	<0.05	-	3	1	<1	10	6	<1	317.2	3	<5	260	-	-	<0.1	-	-	1.7	-	-	<0.5	<0.004	-	260	200	<5	-	-	<0.004	-	88	94	270	-	-	-	650	25	-		
BW6P	26-Apr-2013	-	-	-	-	-	-	-	-	-	-	-	-	-	-	-	-	-	-	-	-	-	-	-	6.58	-	-	-	-	-	-	-	-	-	-	-	-	-	-	-	-	-	-	-
BW6P	06-Dec-2013	300	290	<0.05	-	<1	<1	<1	2	2	<1	305	3	<5	250	-	-	<0.1	-	-	-0.74	-	-	<0.5	<0.004	-	250	600	<5	-	-	<0.004	-	100	88	260	-	-	790	22	-			
BW6P	19-Aug-2015	360	350	<0.05	-	<1	<1	<1	3	2	<1	305	3	-	-	-	-	<0.1	-	-	2.8	-	-	<0.5	<0.004	-	250	100	<5	<5	250	-	<0.004	-	110	98	310	-	-	680	25	-		
BW6P	19-Aug-2015	-	-	-	-	-	-	-	-	-	-	-	-	-	-	-	-	-	-	-	-	-	-	-	7.12	-	-	-	-	-	-	-	-	-	-	-	-	-	-	-	-	-	-	
BW6P	16-Feb-2016	390	390	<0.05	-	<1	<1	<1	3	2	<1	317.2	3	-	-	-	-	<0.1	-	-	11	-	-	<0.5	<0.004	-	260	1500	<5	<5	260	-	<0.004	-	120	100	260	-	-	790	22	-		
BW6P	17-Feb-2016	-	-	-	-	-	-	-	-	-	-	-	-	-	-	-	-	-	-	-	-	-	-	-	7.08	-	-	-	-	-	-	-	-	-	-	-	-	-	-	-	-	-	-	
BW6P	28-Sep-2016	310	320	<0.05	-	<1	<1	<1	4	2	<1	305	3	-	-	11	12.9	<0.1	-	<5	2.5	-	-	<0.5	<0.004	-	250	<100	-	-	250	-	<0.004	440	89	91	310	-	-	660	28	-		
BW6P	28-Sep-2016	-	-	-	-	-	-	-	-	-	-	-	-	-	-	-	-	-	-	-	-	-	-	-	6.85	-	-	-	-	-	-	-	-	-	-	-	-	-	-	-	-	-	-	
BW6P	29-Mar-2017	490	480	<0.05	-	<1	<1	<1	2	2	<1	329.4	3	-	-	-	-	<0.1	-	-	1	-	-	<0.5	<0.004	-	270	200	<5	<5	270	-	<0.004	-	110	88	340	-	-	800	32	-		
BW6P	05-Apr-2017	-	-	-	-	-	-	-	-	-	-	317.2	3	-	-	-	-	<0.1	-	-	-	-	-	<0.004	-	260	<100	<5	<5	260	-	<0.004	-	98	330	-	-	760	30	-				
BW6P	05-Apr-2017	-	-	-	-	-	-	-	-	-	-	-	-	-	-	-	-	-	-	-	-	-	-	-	6.33	-	-	-	-	-	-	-	-	-	-	-	-	-	-	-	-	-	-	
BW6P	29-Sep-2017	420	440	<0.05	-	<1	<1	<1	2	2	<1	305	3	-	-	-	-	<0.1	-	-	4	-	-	<0.5	<0.004	-	250	<100	<5	<5	250	-	<0.004	-	120	100	350	-	-	760	32	-		
BW6P	29-Sep-2017	-	-	-	-	-	-	-	-	-	-	-	-	-	-	-	-	-	-	-	-	-	-	-	6.79	-	-	-	-	-	-	-	-	-	-	-	-	-	-	-	-	-		
BW6P	29-Mar-2018	-	-	-	-	-	-	-	-	-	-	-	-	-	-	-	-	-	-	-	-	-	-	-	6.6	-	-	-	-	-	-	-	-	-	-	-	-	-	-	-	-	-		
BW6P	05-Oct-2018	450	440	<0.05	-	<1	<1	<1	3	2	<1	305	3	-	-	-	-	<0.1	-	-	1	-	-	<0.5	<0.004	-	250	<100	<5	<5	250	-	<0.004	-	96	100	360	-	-	810	31	-		
BW6P	05-Oct-2018	-	-	-	-	-	-	-	-	-	-	-	-	-	-	-	-	-	-	-	-	-	-	-	6.64	-	-	-	-	-	-	-	-	-	-	-	-	-	-	-	-	-		
BW6P	01-May-2019	390	350	<0.05	-	<1	<1	<1	4	2	<1	305	3	-	-	-	-	<0.1	-	-	8	-	-	<0.5	<0.004	-	250	<100	<5	<5	250	-	<0.004	-	91	89	250	-	-	730	26	-		
BW6P	01-May-2019	-	-	-	-	-	-	-	-	-	-	-	-	-	-	-	-	-	-	-	-	-	-	-	6.6	-	-	-	-	-	-	-	-	-	-	-	-	-	-	-	-	-		

Statistical Summary	14	14	11	4	14	14	14	14	14	14	15	15	2	3	2	2	15	1	1	10	1	4	14	15	13	14	15	9	7	8	4	15	1	14	11	11	1	1	14	15	5
Number of Results	14	14	11	4	14	14	14	14	14	14	15	15	2	3	2	2	15	1	1	10	1	4	14	15	13	14	15	9	7	8	4	15	1	14	11	11	1	1	14	15	5
Number of Detects	14	14	0	0	2	2	0	14	14	0	15	14	0	3	2	2	1	0	0	10	1	4	0	0	13	14	8	0	0	8	2	1	1	14	11	11	1	1	14	15	2
Minimum Concentration	190	190	<0.02	<0.1	0.06	0.07	<0.2	2	1.6	<0.05	267	<1	<5	250	9.12	9.91	0.0007	<1000	<5	-0																					

	Ammonia as N (Filtered)	Nitrate (as N)	Nitrate (as N) (Filtered)	Nitrite (as N)	Nitrite (as N) (Filtered)	Kjeldahl Nitrogen Total	Kjeldahl Nitrogen Total (Filtered)
	mg/L	mg/L	mg/L	mg/L	mg/L	mg/L	mg/L
EQL	0.005		0.005	0.005	0.005		0.1

Location Code	Sampled Date Time							
BW6P	01-May-2011	-	<0.005	-	0.015	-	<0.01	-
BW6P	20-May-2011	-	-	-	-	-	-	-
BW6P	01-Sep-2011	-	-	<0.02 - 0.34	-	0.42	< 0.2	-
BW6P	01-Sep-2011	-	-	< 0.02	-	0.37	< 0.2	-
BW6P	09-Sep-2011	-	-	-	-	-	-	-
BW6P	01-Dec-2011	-	-	< 0.02	-	< 0.02	< 0.2	-
BW6P	16-Dec-2011	-	-	-	-	-	-	-
BW6P	01-Mar-2012	-	-	< 0.05	-	-	< 0.2	-
BW6P	01-Mar-2012	-	-	< 0.02	-	< 0.02	< 0.2	-
BW6P	17-Mar-2012	-	-	-	-	-	-	-
BW6P	26-Apr-2013	-	-	-	-	-	-	-
BW6P	26-Apr-2013	0.018	-	<0.005	<0.005	-	-	0.2
BW6P	26-Apr-2013	-	-	-	-	-	-	-
BW6P	06-Dec-2013	<0.005	-	<0.005	<0.005	-	-	0.6
BW6P	19-Aug-2015	0.016	-	<0.005	<0.005	-	-	0.1
BW6P	19-Aug-2015	-	-	-	-	-	-	-
BW6P	16-Feb-2016	0.031	-	<0.005	<0.005	-	-	1.5
BW6P	17-Feb-2016	-	-	-	-	-	-	-
BW6P	28-Sep-2016	0.02	-	0.008	-	<0.005	-	<0.1
BW6P	28-Sep-2016	-	-	-	-	-	-	-
BW6P	29-Mar-2017	0.12	-	<0.005	<0.005	-	-	<0.1
BW6P	05-Apr-2017	0.036	-	<0.005	<0.005	-	-	<0.1
BW6P	05-Apr-2017	-	-	-	-	-	-	-
BW6P	29-Sep-2017	0.055	-	<0.005	<0.005	-	-	<0.1
BW6P	29-Sep-2017	-	-	-	-	-	-	-
BW6P	29-Mar-2018	-	-	-	-	-	-	-
BW6P	05-Oct-2018	0.017	-	0.005	<0.005	-	-	<0.1
BW6P	05-Oct-2018	-	-	-	-	-	-	-
BW6P	01-May-2019	0.068	-	<0.005	<0.005	-	-	<0.1
BW6P	01-May-2019	-	-	-	-	-	-	-

Statistical Summary							
Number of Results	10	1	15	10	5	6	10
Number of Detects	9	0	3	1	2	0	4
Minimum Concentration	<0.005	<0.005	<0.005	<0.005	<0.005	<0.01	<0.1
Maximum Concentration	0.12	<0.005	0.34	0.015	0.42	<0.2	1.5
Median Concentration	0.0255	0.0025	0.0025	0.0025	0.01	0.1	0.05
Standard Deviation	0.035		0.044	0.004	0.21	0.039	0.46

Metals-022 ICP-MS

UNK

	Uranium (Filtered)	Arsenic	Arsenic (Filtered)	Barium (Filtered)	Beryllium (Filtered)	Boron (Filtered)	Cadmium	Cadmium (Filtered)	Chromium (III+VI) (Filtered)	Cobalt	Cobalt (Filtered)	Copper	Copper (Filtered)	Molybdenum (Filtered)	Silver (Filtered)	Tin (Filtered)	Aluminium	Aluminium (Filtered)	Iron	Iron (Filtered)	Lead	Lead (Filtered)	Manganese	Manganese (Filtered)	Nickel	Nickel (Filtered)	Selenium (Filtered)	Zinc	Zinc (Filtered)	Vanadium (Filtered)	Anions Total	Cations Total	Thiocyanates (total)
	µg/L	µg/L	µg/L	µg/L	µg/L	µg/L	µg/L	µg/L	µg/L	µg/L	µg/L	µg/L	µg/L	µg/L	µg/L	µg/L	µg/L	µg/L	mg/L	mg/L	µg/L	µg/L	µg/L	µg/L	µg/L	µg/L	µg/L	µg/L	µg/L	meq/L	meq/L	µg/L	
EQL	0.5	1	1	1	0.5	5	0.1	0.1	1	1	1	1	1	1	1	1	10	10	0.01	0.01	1	1	5	5	1	1	1	1	1	1	0	0	100
WDL 178-06			140					0.8			13		2.5					150		0.35		9.4		3600		17		31					
WDL 178-06 x 2			280					1.6			26		5					300		0.7		18.8		7200		34		62					

Field ID	Location Code	Sampled Date Time	Uranium (Filtered)	Arsenic	Arsenic (Filtered)	Barium (Filtered)	Beryllium (Filtered)	Boron (Filtered)	Cadmium	Cadmium (Filtered)	Chromium (III+VI) (Filtered)	Cobalt	Cobalt (Filtered)	Copper	Copper (Filtered)	Molybdenum (Filtered)	Silver (Filtered)	Tin (Filtered)	Aluminium	Aluminium (Filtered)	Iron	Iron (Filtered)	Lead	Lead (Filtered)	Manganese	Manganese (Filtered)	Nickel	Nickel (Filtered)	Selenium (Filtered)	Zinc	Zinc (Filtered)	Vanadium (Filtered)	Anions Total	Cations Total	Thiocyanates (total)	
WDMB02	WDMB02	15-Dec-2011	-	-	-	-	-	-	-	-	-	-	-	-	-	-	-	-	-	-	-	-	-	-	-	-	-	-	-	-	-	-	-	-	-	
WDMB02	WDMB02	10-Mar-2012	-	-	-	-	-	-	-	-	-	-	-	-	-	-	-	-	-	-	-	-	-	-	-	-	-	-	-	-	-	-	-	-	-	-
WDMB02	WDMB02	24-Apr-2013	-	-	-	-	-	-	-	-	-	-	-	-	-	-	-	-	-	-	-	-	-	-	-	-	-	-	-	-	-	-	-	-	-	-
WDMB02	WDMB02	04-Dec-2013	-	-	-	-	-	-	-	-	-	-	-	-	-	-	-	-	-	-	-	-	-	-	-	-	-	-	-	-	-	-	-	-	-	-
WDMB02	WDMB02	02-Jun-2014	-	-	-	-	-	-	-	-	-	-	-	-	-	-	-	-	-	-	-	-	-	-	-	-	-	-	-	-	-	-	-	-	-	-
WDMB02	WDMB02	21-Jan-2015	-	-	-	-	-	-	-	-	-	-	-	-	-	-	-	-	-	-	-	-	-	-	-	-	-	-	-	-	-	-	-	-	-	-
WDMB02	WDMB02	19-Aug-2015	-	-	-	-	-	-	-	-	-	-	-	-	-	-	-	-	-	-	-	-	-	-	-	-	-	-	-	-	-	-	-	-	-	-
WDMB02	WDMB02	16-Feb-2016	-	-	-	-	-	-	-	-	-	-	-	-	-	-	-	-	-	-	-	-	-	-	-	-	-	-	-	-	-	-	-	-	-	-
WDMB02	WDMB02	28-Sep-2016	-	-	-	-	-	-	-	-	-	-	-	-	-	-	-	-	-	-	-	-	-	-	-	-	-	-	-	-	-	-	-	-	-	-
WDMB02	WDMB02	05-Apr-2017	-	-	-	-	-	-	-	-	-	-	-	-	-	-	-	-	-	-	-	-	-	-	-	-	-	-	-	-	-	-	-	-	-	-
WDMB02	WDMB02	27-Sep-2017	-	-	-	-	-	-	-	-	-	-	-	-	-	-	-	-	-	-	-	-	-	-	-	-	-	-	-	-	-	-	-	-	-	-
WDMB02	WDMB02	28-Mar-2018	-	-	-	-	-	-	-	-	-	-	-	-	-	-	-	-	-	-	-	-	-	-	-	-	-	-	-	-	-	-	-	-	-	-
WDMB02	WDMB02	04-Oct-2018	-	-	-	-	-	-	-	-	-	-	-	-	-	-	-	-	-	-	-	-	-	-	-	-	-	-	-	-	-	-	-	-	-	-
WDMB02	WDMB02	30-Apr-2019	-	-	-	-	-	-	-	-	-	-	-	-	-	-	-	-	-	-	-	-	-	-	-	-	-	-	-	-	-	-	-	-	-	-
E533	WDMB02	01-Sep-2011	-	-	-	-	-	-	-	-	-	-	-	-	-	-	-	-	-	-	-	-	-	-	-	-	-	-	-	-	-	-	-	-	-	-
E534	WDMB02	01-Sep-2011	-	-	-	-	-	-	-	-	-	-	-	-	-	-	-	-	-	-	-	-	-	-	-	-	-	-	-	-	-	-	-	-	-	-
E977	WDMB02	01-Mar-2012	-	-	-	-	-	-	-	-	-	-	-	-	-	-	-	-	-	-	-	-	-	-	-	-	-	-	-	-	-	-	-	-	-	-
E978	WDMB02	01-Mar-2012	-	-	-	-	-	-	-	-	-	-	-	-	-	-	-	-	-	-	-	-	-	-	-	-	-	-	-	-	-	-	-	-	-	-
EM92-Mt Todd Bore	WDMB02	24-Apr-2013	<0.5	35	22	78	<0.5	8	<0.1	<0.1	<1	<1	<1	<1	<1	<1	<1	<1	460	<10	2.4	1.3	9	<1	810	760	4	<1	<1	7	2	<1	-	-	<100	
Job 125-Mt Todd Bore DEC-2013	WDMB02	04-Dec-2013	<0.5	69	21	80	<0.5	18	<0.1	<0.1	<1	<1	<1	<1	<1	<1	<1	<1	400	<10	4.6	1.2	9	<1	1100	780	2	1	<1	2	<1	<1	-	-	-	
Job 140-Mt Todd Bore JUN-2014	WDMB02	02-Jun-2014	<0.5	24	22	90	<0.5	17	<0.1	<0.1	<1	<1	1	<1	<1	<1	<1	<1	100	<10	1.4	1.1	2	<1	920	890	2	2	<1	2	<1	<1	-	-	-	
Job 156-Mt Todd Bore JAN-2015	WDMB02	21-Jan-2015	<0.5	33	24	89	<0.5	20	<0.1	<0.1	<1	<1	<1	<1	<1	<1	<1	<1	430	<10	2.4	1.5	2	<1	1100	1000	<1	<1	<1	3	1	<1	-	-	-	
Job 171 - Mt Todd Bore AUG 2015	WDMB02	19-Aug-2015	<0.5	24	22	91	<0.5	16	<0.1	<0.1	<1	<1	<1	<1	<1	<1	<1	<1	80	<10	1.5	1.3	<1	<1	1100	1000	<1	<1	<1	2	<1	<1	-	-	-	
Job 171 - Mt Todd Bore FEB 2016	WDMB02	16-Feb-2016	<0.5	23	23	96	<0.5	20	<0.1	<0.1	<1	<1	<1	<1	<1	<1	<1	<1	10	<10	1.8	1.7	<1	<1	1100	1100	3	<1	<1	2	2	<1	-	-	-	
Job 171 - Mt Todd Bore FEB 2016	WDMB02	16-Feb-2016	<0.5	22	23	93	<0.5	19	<0.1	<0.1	<1	<1	<1	<1	<1	<1	<1	<1	20	<10	1.8	1.7	<1	<1	1100	1000	4	<1	<1	2	<1	<1	-	-	-	
Job 193 - Mt Todd Bore Sep 2016	WDMB02	28-Sep-2016	-	-	-	-	-	-	-	-	-	-	-	-	-	-	-	-	-	-	-	-	-	-	-	-	-	-	-	-	-	-	-	11	12.5	-
Job 213 - Mt Todd Bore April 2017	WDMB02	05-Apr-2017	-	-	-	-	-	-	-	-	-	-	-	-	-	-	-	-	-	-	-	-	-	-	-	-	-	-	-	-	-	-	-	-	-	-
Job 223 - Mt Todd Bore Sep 2017	WDMB02	29-Sep-2017	-	-	-	-	-	-	-	-	-	-	-	-	-	-	-	-	-	-	-	-	-	-	-	-	-	-	-	-	-	-	-	-	-	-
Job 232 - Mt Todd Bore MAR 2018	WDMB02	28-Mar-2017	-	-	-	-	-	-	-	-	-	-	-	-	-	-	-	-	-	-	-	-	-	-	-	-	-	-	-	-	-	-	-	-	-	-
Job 232 - Mt Todd Bore MAR 2018	WDMB02	28-Mar-2017	-	-	-	-	-	-	-	-	-	-	-	-	-	-	-	-	-	-	-	-	-	-	-	-	-	-	-	-	-	-	-	-	-	-
Job 241 - Mt Todd Bore OCT 2018	WDMB02	04-Oct-2018	-	-	-	-	-	-	-	-	-	-	-	-	-	-	-	-	-	-	-	-	-	-	-	-	-	-	-	-	-	-	-	-	-	-
Job 248 - Mt Todd Bore April 2019	WDMB02	30-Apr-2019	-	-	-	-	-	-	-	-	-	-	-	-	-	-	-	-	-	-	-	-	-	-	-	-	-	-	-	-	-	-	-	-	-	-
SITE 12 E734-E738	WDMB02	01-Dec-2011	-	-	-	-	-	-	-	-	-	-	-	-	-	-	-	-	-	-	-	-	-	-	-	-	-	-	-	-	-	-	-	-	-	-

Statistical Summary			Uranium (Filtered)	Arsenic	Arsenic (Filtered)	Barium (Filtered)	Beryllium (Filtered)	Boron (Filtered)	Cadmium	Cadmium (Filtered)	Chromium (III+VI) (Filtered)	Cobalt	Cobalt (Filtered)	Copper	Copper (Filtered)	Molybdenum (Filtered)	Silver (Filtered)	Tin (Filtered)	Aluminium	Aluminium (Filtered)	Iron	Iron (Filtered)	Lead	Lead (Filtered)	Manganese	Manganese (Filtered)	Nickel	Nickel (Filtered)	Selenium (Filtered)	Zinc	Zinc (Filtered)	Vanadium (Filtered)	Anions Total	Cations Total	Thiocyanates (total)	
Number of Results			7	7	7	7	7	7	7	7	7	7	7	7	7	7	7	7	7	7	7	7	7	7	7	7	7	7	7	7	7	7	7	7	7	7
Number of Detects			0	7	7	7	0	7	0	0	0	0	1	2	0	0	0	0	0	7	0	7	7	4	0	7	7	5	2	0	7	3	0	1	1	0
Minimum Concentration			<0.5	22	21	78	<0.5	8	<0.1	<0.1	<1	<1	<1	<1	<1	<1	<1	<1	<1	10	<10	1.4	1.1	<1	<1	810	760	<1	<1	<1	2	<1	<1	11	12.5	<100
Maximum Concentration			<0.5	69	24	96	<0.5	20	<0.1	<0.1	<1	<1	1	2	<1	<1	<1	<1	460	<10	4.6	1.7	9	<1	1100	1100	4	2	<1	7	2	<1	11	12.5	<100	
Median Concentration			0.25	24	22	90	0.25	18	0.05	0.05	0.5	0.5	0.5	0.5	0.5	0.5	0.5	0.5	100	5	1.8	1.3	2	0.5	1100	1000	2	0.5	0.5	2	0.5	0.5	11	12.5	50	
Standard Deviation			0	17	0.98	6.7	0	4.2	0	0	0	0	0.19	0.57	0	0	0	0	205	0	1.1	0.24	3.9	0	119	127	1.5	0.57	0	1.9	0.71	0				

														UNK		
	Iron	Iron (Filtered)	Lead	Lead (Filtered)	Manganese	Manganese (Filtered)	Nickel	Nickel (Filtered)	Selenium (Filtered)	Zinc	Zinc (Filtered)	Vanadium (Filtered)	Anions Total	Cations Total	Thiocyanates (total)	
	mg/L	mg/L	µg/L	µg/L	µg/L	µg/L	µg/L	µg/L	µg/L	µg/L	µg/L	µg/L	meq/L	meq/L	µg/L	
EQL	0.01	0.01	1	1	5	5	1	1	1	1	1	1	0	0	100	
WDL 178-06		0.35		9.4		3600		17			31					
WDL 178-06 x 2		0.7		18.8		7200		34			62					

Field_ID	Location Code	Sampled Date Time														
	TDMB2S	26-Feb-2011	-	-	-	-	-	-	-	-	-	-	-	-	-	-
	TDMB2S	25-May-2011	-	-	-	-	-	-	-	-	-	-	-	-	-	-
	TDMB2S	30-May-2011	-	-	-	-	-	-	-	-	-	-	-	-	-	-
	TDMB2S	08-Sep-2011	-	-	-	-	-	-	-	-	-	-	-	-	-	-
	TDMB2S	17-Dec-2011	-	-	-	-	-	-	-	-	-	-	-	-	-	-
	TDMB2S	12-Mar-2012	-	-	-	-	-	-	-	-	-	-	-	-	-	-
	TDMB2S	25-Apr-2013	-	-	-	-	-	-	-	-	-	-	-	-	-	-
	TDMB2S	05-Dec-2013	-	-	-	-	-	-	-	-	-	-	-	-	-	-
	TDMB2S	04-Jun-2014	-	-	-	-	-	-	-	-	-	-	-	-	-	-
	TDMB2S	22-Jan-2015	-	-	-	-	-	-	-	-	-	-	-	-	-	-
	TDMB2S	20-Aug-2015	-	-	-	-	-	-	-	-	-	-	-	-	-	-
	TDMB2S	18-Feb-2016	-	-	-	-	-	-	-	-	-	-	-	-	-	-
	TDMB2S	29-Sep-2016	-	-	-	-	-	-	-	-	-	-	-	-	-	-
	TDMB2S	07-Apr-2017	-	-	-	-	-	-	-	-	-	-	-	-	-	-
	TDMB2S	28-Sep-2017	-	-	-	-	-	-	-	-	-	-	-	-	-	-
	TDMB2S	29-Mar-2018	-	-	-	-	-	-	-	-	-	-	-	-	-	-
	TDMB2S	05-Oct-2018	-	-	-	-	-	-	-	-	-	-	-	-	-	-
	TDMB2S	26-Feb-2019	-	-	-	-	-	-	-	-	-	-	-	-	-	-
	TDMB2S	01-May-2019	-	-	-	-	-	-	-	-	-	-	-	-	-	-
E570	TDMB2S	01-Sep-2011	-	-	-	-	-	-	-	-	-	-	-	-	-	-
E573	TDMB2S	01-Sep-2011	-	-	-	-	-	-	-	-	-	-	-	-	-	-
E574	TDMB2S	01-Sep-2011	-	-	-	-	-	-	-	-	-	-	-	-	-	-
EM92-Mt Todd Bore	TDMB2S	25-Apr-2013	11	-	<1	-	9200	-	3	-	5	-	-	-	-	7100
EM92-Mt Todd Bore	TDMB2S	25-Apr-2013	11	11	1	<1	9200	9100	2	3	<1	6	4	<1	-	7100
Job 125-Mt Todd Bore DEC-2013	TDMB2S	05-Dec-2013	28	24	<1	<1	16,000	14,000	4	4	<1	3	1	<1	-	-
Job 140-Mt Todd Bore JUN-2014	TDMB2S	04-Jun-2014	28	35	<1	<1	17,000	16,000	2	2	<1	2	1	<1	-	-
Job 156-Mt Todd Bore JAN-2015	TDMB2S	22-Jan-2015	11	10	<1	<1	9900	9600	1	2	<1	4	2	<1	-	-
Job 171 - Mt Todd Bore AUG 2015	TDMB2S	20-Aug-2015	6.7	7.3	<1	<1	8400	8800	2	2	<1	7	6	<1	-	-
Job 171 - Mt Todd Bore FEB 2016	TDMB2S	18-Feb-2016	17	16	<1	<1	11,000	10,000	2	2	<1	4	2	<1	-	-
Job 171 - Mt Todd Bore FEB 2016	TDMB2S	18-Feb-2016	16	16	<1	<1	10,000	10,000	2	2	<1	3	2	<1	-	-
Job 193 - Mt Todd Bore Sep 2016	TDMB2S	29-Sep-2016	-	-	-	-	-	-	-	-	-	-	-	-	51.7	-
Job 193 - Mt Todd Bore Sep 2016	TDMB2S	29-Sep-2016	-	-	-	-	-	-	-	-	-	-	51	51.7	-	-
Job 213 - Mt Todd Bore April 2017	TDMB2S	07-Apr-2017	-	-	-	-	-	-	-	-	-	-	-	-	-	-
Job 213 - Mt Todd Bore April 2017	TDMB2S	07-Apr-2017	-	-	-	-	-	-	-	-	-	-	-	-	-	-
Job 223 - Mt Todd Bore Sep 2017	TDMB2S	29-Sep-2017	-	-	-	-	-	-	-	-	-	-	-	-	-	-
Job 232 - Mt Todd Bore MAR 2018	TDMB2S	29-Mar-2017	-	-	-	-	-	-	-	-	-	-	-	-	-	-
SITE 21 E781-E785	TDMB2S	01-Dec-2011	-	-	-	-	-	-	-	-	-	-	-	-	-	-

Statistical Summary																
Number of Results			8	7	8	7	8	7	7	8	7	7	1	2	2	
Number of Detects			8	7	1	0	8	7	8	7	0	8	7	0	1	2
Minimum Concentration			6.7	7.3	<1	<1	8400	8800	1	2	<1	2	1	<1	51	51.7
Maximum Concentration			28	35	1	<1	17000	16000	4	4	<1	7	6	<1	51	51.7
Average Concentration			16	17	0.56	0.5	11338	11071	2.3	2.4	0.5	4.3	2.6	0.5		
Standard Deviation			8	9.6	0.18	0	3285	2780	0.89	0.79	0	1.7	1.8	0		

	Ext-054	Historical				INORG-006										Inorg-013				Inorg-014	
	Cyanide (amenable) mg/L	DO (Field) mg/L	EC (field) uS/cm	Temp (Field) °C	pH (Field) pH_Unit	Alkalinity (Bicarbonate) mg/L	Alkalinity (Carbonate) mg/L	Alkalinity (Hydroxide) mg/L	Alkalinity (total) mg/L	Carbonate Alkalinity as CaCO3_ mg/L	Hydroxide as CaCO3 mg/L	Alkalinity (Bicarbonate as CaCO3) mg/L	Alkalinity (Carbonate as CaCO3) mg/L	Alkalinity (Hydroxide) as CaCO3 mg/L	Alkalinity (total) as CaCO3 mg/L	Cyanide (amenable) mg/L	Thiocyanic Acid mg/L	Cyanide (Free) mg/L	Cyanide Total mg/L	Weak Acid Dissociable Cyanide mg/L	Cyanide (Free) mg/L
EQL	0.005							5	5	5	5	5	5	5	5	0.1	0.1	0.004	0.004	0.004	0.004
WDL 178-06																					
WDL 178-06 x 2					6-8																

Field ID Location Code Sampled Date Time

	SW04MB01	07-Sep-2011	-	-	314	30.33	6.38	-	-	-	-	-	-	-	-	-	-	-	-	-	-	-	
	SW04MB01	15-Dec-2011	-	-	294	30.4	6.3	-	-	-	-	-	-	-	-	-	-	-	-	-	-	-	
	SW04MB01	09-Mar-2012	-	-	129	30.1	5.45	-	-	-	-	-	-	-	-	-	-	-	-	-	-	-	
	SW04MB01	23-Apr-2013	-	-	241	30.7	6.3	-	-	-	-	-	-	-	-	-	-	-	-	-	-	-	
	SW04MB01	04-Dec-2013	-	-	272	30.97	6.46	-	-	-	-	-	-	-	-	-	-	-	-	-	-	-	
	SW04MB01	02-Jun-2014	-	-	265	30.5	6.33	-	-	-	-	-	-	-	-	-	-	-	-	-	-	-	
	SW04MB01	21-Jan-2015	-	-	148	30.08	6.45	-	-	-	-	-	-	-	-	-	-	-	-	-	-	-	
	SW04MB01	19-Aug-2015	-	-	263	28.89	6.45	-	-	-	-	-	-	-	-	-	-	-	-	-	-	-	
	SW04MB01	16-Feb-2016	-	-	95	29.95	5.5	-	-	-	-	-	-	-	-	-	-	-	-	-	-	-	
	SW04MB01	27-Sep-2016	-	1.6	243	31.01	6.13	-	-	-	-	-	-	-	-	-	-	-	-	-	-	-	
	SW04MB01	04-Apr-2017	-	0.6	229	29.7	6.57	-	-	-	-	-	-	-	-	-	-	-	-	-	-	-	
	SW04MB01	27-Sep-2017	-	0.08	246	31.42	6.42	-	-	-	-	-	-	-	-	-	-	-	-	-	-	-	
Job 125-Mt Todd Bore DEC-2013	SW04MB01	04-Dec-2013	-	-	-	-	-	122	3	<5	100	-	-	100	<5	-	-	<0.1	<0.1	<0.004	<0.004	-	-
Job 140-Mt Todd Bore JUN-2014	SW04MB01	02-Jun-2014	-	-	-	-	-	120.78	3	<5	99	-	-	99	<5	-	-	<0.1	0.2	-	-	<0.004	<0.004
Job 171 - Mt Todd Bore FEB 2016	SW04MB01	16-Feb-2016	-	-	-	-	-	36.6	3	-	-	-	-	30	<5	<5	30	-	-	-	-	<0.004	<0.004
Job 193 - Mt Todd Bore Sep 2016	SW04MB01	27-Sep-2016	<0.1	-	-	-	-	112.24	3	-	-	<5	<5	92	-	-	92	-	-	-	-	<0.004	<0.004

Statistical Summary																							
Number of Results	1	3	12	12	12	12	4	4	2	2	1	1	4	3	1	2	2	2	2	1	1	3	3
Number of Detects	0	3	12	12	12	12	4	4	0	2	0	0	4	0	0	2	0	1	0	0	0	0	0
Minimum Concentration	<0.1	0.08	95	28.89	5.45	36.6	3	3	<5	99	<5	<5	30	<5	<5	30	<0.1	<0.1	<0.004	<0.004	<0.004	<0.004	<0.004
Maximum Concentration	<0.1	1.6	314	31.42	6.57	122	3	3	<5	100	<5	<5	100	<5	<5	92	<0.1	0.2	<0.004	<0.004	<0.004	<0.004	<0.004
Median Concentration	0.05	0.6	244.5	30.365	6.355	116.51	3	3	2.5	99.5	2.5	2.5	95.5	2.5	2.5	61	0.05	0.125	0.002	0.002	0.002	0.002	0.002
Standard Deviation		0.77	68	0.67	0.37	41	0	0					34	0							0	0	0

	Inorg-018	Inorg-040	Inorg-041	INORG-055			Inorg-055/062	Inorg-057	Inorg-062	Inorg-081	Inorg-083	Inorg-089				
	Cyanide Total	TDS (Filtered)	Ionic Balance	Ionic Balance	Nitrogen (Total)	Nitrate (as N) (Filtered)	Nitrite (as N)	Nitrite (as N) (Filtered)	Nitrogen (Total)	Ammonia as N (Filtered)	Kjeldahl Nitrogen Total (Filtered)	Sulphate	Chloride	Cyanide (amenable)	Weak Acid Dissociable Cyanide	Thiocyanic Acid
	mg/L	mg/L	%	%	µg/L	mg/L	mg/L	mg/L	µg/L	mg/L	mg/L	mg/L	mg/L	mg/L	mg/L	mg/L
EQL	0.004	5			100	0.005	0.005	0.005	100	0.005	0.1	1	1	0.1	0.004	0.1
WDL 178-06																
WDL 178-06 x 2																

Field ID Location Code Sampled Date Time

	SW04MB01	07-Sep-2011	-	-	-	-	-	-	-	-	-	-	-	-	-	-	-	
	SW04MB01	15-Dec-2011	-	-	-	-	-	-	-	-	-	-	-	-	-	-	-	
	SW04MB01	09-Mar-2012	-	-	-	-	-	-	-	-	-	-	-	-	-	-	-	
	SW04MB01	23-Apr-2013	-	-	-	-	-	-	-	-	-	-	-	-	-	-	-	
	SW04MB01	04-Dec-2013	-	-	-	-	-	-	-	-	-	-	-	-	-	-	-	
	SW04MB01	02-Jun-2014	-	-	-	-	-	-	-	-	-	-	-	-	-	-	-	
	SW04MB01	21-Jan-2015	-	-	-	-	-	-	-	-	-	-	-	-	-	-	-	
	SW04MB01	19-Aug-2015	-	-	-	-	-	-	-	-	-	-	-	-	-	-	-	
	SW04MB01	16-Feb-2016	-	-	-	-	-	-	-	-	-	-	-	-	-	-	-	
	SW04MB01	27-Sep-2016	-	-	-	-	-	-	-	-	-	-	-	-	-	-	-	
	SW04MB01	04-Apr-2017	-	-	-	-	-	-	-	-	-	-	-	-	-	-	-	
	SW04MB01	27-Sep-2017	-	-	-	-	-	-	-	-	-	-	-	-	-	-	-	
Job 125-Mt Todd Bore DEC-2013	SW04MB01	04-Dec-2013	-	190	-	-6.7	-	0.35	<0.005	-	700	0.033	0.4	5	16	-	<0.004	-
Job 140-Mt Todd Bore JUN-2014	SW04MB01	02-Jun-2014	<0.004	180	-	3.7	-	<0.005	<0.005	-	<100	0.042	<0.1	4	17	-	-	-
Job 171 - Mt Todd Bore FEB 2016	SW04MB01	16-Feb-2016	<0.004	57	-	-1.2	-	0.089	<0.005	-	1500	0.005	1.4	2	8	<0.1	-	<0.1
Job 193 - Mt Todd Bore Sep 2016	SW04MB01	27-Sep-2016	<0.004	140	1.9	-	<100	<0.005	-	<0.005	-	0.024	<0.1	4	18	-	-	<0.5

Statistical Summary																		
Number of Results			3	4	1	3	1	4	3	1	3	4	4	4	4	1	1	2
Number of Detects			0	4	1	3	0	2	0	0	2	4	2	4	4	0	0	0
Minimum Concentration			<0.004	57	1.9	-6.7	<100	<0.005	<0.005	<0.005	<100	0.005	<0.1	2	8	<0.1	<0.004	<0.1
Maximum Concentration			<0.004	190	1.9	3.7	<100	0.35	<0.005	<0.005	1500	0.042	1.4	5	18	<0.1	<0.004	<0.5
Median Concentration			0.002	160	1.9	-1.2	50	0.04575	0.0025	0.0025	700	0.0285	0.225	4	16.5	0.05	0.002	0.15
Standard Deviation			0	60		5.2		0.16	0		726	0.016	0.64	1.3	4.6			

	METALS-008	METALS-020							Metals-020 ICP-AES										Metals-021		
	Hardness as CaCO3	Phosphorus	Sodium	Sodium (Filtered)	Calcium	Calcium (Filtered)	Magnesium	Magnesium (Filtered)	Potassium	Potassium (Filtered)	Phosphorus	Sodium	Sodium (Filtered)	Calcium	Calcium (Filtered)	Magnesium	Magnesium (Filtered)	Potassium	Potassium (Filtered)	Mercury	
	mg/L	µg/L	mg/L	mg/L	mg/L	mg/L	mg/L	mg/L	mg/L	mg/L	µg/L	mg/L	mg/L	mg/L	mg/L	mg/L	mg/L	mg/L	mg/L	µg/L	
EQL	3	50	0.5	0.5	0.5	0.5	0.5	0.5	0.5	0.5	50	0.5	0.5	0.5	0.5	0.5	0.5	0.5	0.5	0.5	0.05
WDL 178-06																					
WDL 178-06 x 2																					

Field ID Location Code Sampled Date Time

Field ID	Location Code	Sampled Date Time	Hardness as CaCO3	Phosphorus	Sodium	Sodium (Filtered)	Calcium	Calcium (Filtered)	Magnesium	Magnesium (Filtered)	Potassium	Potassium (Filtered)	Phosphorus	Sodium	Sodium (Filtered)	Calcium	Calcium (Filtered)	Magnesium	Magnesium (Filtered)	Potassium	Potassium (Filtered)	Mercury
	SW04MB01	07-Sep-2011	-	-	-	-	-	-	-	-	-	-	-	-	-	-	-	-	-	-	-	-
	SW04MB01	15-Dec-2011	-	-	-	-	-	-	-	-	-	-	-	-	-	-	-	-	-	-	-	-
	SW04MB01	09-Mar-2012	-	-	-	-	-	-	-	-	-	-	-	-	-	-	-	-	-	-	-	-
	SW04MB01	23-Apr-2013	-	-	-	-	-	-	-	-	-	-	-	-	-	-	-	-	-	-	-	-
	SW04MB01	04-Dec-2013	-	-	-	-	-	-	-	-	-	-	-	-	-	-	-	-	-	-	-	-
	SW04MB01	02-Jun-2014	-	-	-	-	-	-	-	-	-	-	-	-	-	-	-	-	-	-	-	-
	SW04MB01	21-Jan-2015	-	-	-	-	-	-	-	-	-	-	-	-	-	-	-	-	-	-	-	-
	SW04MB01	19-Aug-2015	-	-	-	-	-	-	-	-	-	-	-	-	-	-	-	-	-	-	-	-
	SW04MB01	16-Feb-2016	-	-	-	-	-	-	-	-	-	-	-	-	-	-	-	-	-	-	-	-
	SW04MB01	27-Sep-2016	-	-	-	-	-	-	-	-	-	-	-	-	-	-	-	-	-	-	-	-
	SW04MB01	04-Apr-2017	-	-	-	-	-	-	-	-	-	-	-	-	-	-	-	-	-	-	-	-
	SW04MB01	27-Sep-2017	-	-	-	-	-	-	-	-	-	-	-	-	-	-	-	-	-	-	-	-
Job 125-Mt Todd Bore DEC-2013	SW04MB01	04-Dec-2013	-	-	-	-	-	-	-	-	-	-	200	28	18	15	14	10	9.5	2.5	2	-
Job 140-Mt Todd Bore JUN-2014	SW04MB01	02-Jun-2014	-	-	-	-	-	-	-	-	-	-	200	36	25	18	15	9.8	10	1.9	2.2	-
Job 171 - Mt Todd Bore FEB 2016	SW04MB01	16-Feb-2016	-	-	-	-	-	-	-	-	-	-	<50	8.2	7.8	2.4	2.5	3.7	4.1	2	1.8	-
Job 193 - Mt Todd Bore Sep 2016	SW04MB01	27-Sep-2016	77	170	21	21	13	13	11	11	2.3	2.4	-	-	-	-	-	-	-	-	-	<0.05

Statistical Summary	Hardness as CaCO3	Phosphorus	Sodium	Sodium (Filtered)	Calcium	Calcium (Filtered)	Magnesium	Magnesium (Filtered)	Potassium	Potassium (Filtered)	Phosphorus	Sodium	Sodium (Filtered)	Calcium	Calcium (Filtered)	Magnesium	Magnesium (Filtered)	Potassium	Potassium (Filtered)	Mercury	
Number of Results	1	1	1	1	1	1	1	1	1	1	3	3	3	3	3	3	3	3	3	3	1
Number of Detects	1	1	1	1	1	1	1	1	1	1	2	3	3	3	3	3	3	3	3	3	0
Minimum Concentration	77	170	21	21	13	13	11	11	2.3	2.4	<50	8.2	7.8	2.4	2.5	3.7	4.1	1.9	1.8	<0.05	
Maximum Concentration	77	170	21	21	13	13	11	11	2.3	2.4	200	36	25	18	15	10	10	2.5	2.2	<0.05	
Median Concentration	77	170	21	21	13	13	11	11	2.3	2.4	200	28	18	15	14	9.8	9.5	2	2	0.025	
Standard Deviation											101	14	8.6	8.3	6.9	3.6	3.3	0.32	0.2		

	Metals-021 CV-AAS						Metals-022																	
	Mercury	Antimony (Filtered)	Bismuth (Filtered)	Lithium (Filtered)	Strontium (Filtered)	Thallium (Filtered)	Thorium (Filtered)	Titanium (Filtered)	Uranium (Filtered)	Arsenic	Arsenic (Filtered)	Barium (Filtered)	Beryllium (Filtered)	Boron (Filtered)	Cadmium	Cadmium (Filtered)	Chromium (III+VI) (Filtered)	Cobalt	Cobalt (Filtered)	Copper	Copper (Filtered)	Molybdenum (Filtered)	Silver (Filtered)	Tin (Filtered)
	µg/L	µg/L	µg/L	µg/L	µg/L	µg/L	µg/L	µg/L	µg/L	µg/L	µg/L	µg/L	µg/L	µg/L	µg/L	µg/L	µg/L	µg/L	µg/L	µg/L	µg/L	µg/L	µg/L	µg/L
EQL	0.05	1	1	0.5	1	1	0.5	1	0.5	1	1	1	0.5	5	0.1	0.1	1	1	1	1	1	1	1	1
WDL 178-06																								
WDL 178-06 x 2																								

Field ID	Location Code	Sampled Date Time	Mercury	Antimony (Filtered)	Bismuth (Filtered)	Lithium (Filtered)	Strontium (Filtered)	Thallium (Filtered)	Thorium (Filtered)	Titanium (Filtered)	Uranium (Filtered)	Arsenic	Arsenic (Filtered)	Barium (Filtered)	Beryllium (Filtered)	Boron (Filtered)	Cadmium	Cadmium (Filtered)	Chromium (III+VI) (Filtered)	Cobalt	Cobalt (Filtered)	Copper	Copper (Filtered)	Molybdenum (Filtered)	Silver (Filtered)	Tin (Filtered)
	SW04MB01	07-Sep-2011	-	-	-	-	-	-	-	-	-	-	-	-	-	-	-	-	-	-	-	-	-	-	-	-
	SW04MB01	15-Dec-2011	-	-	-	-	-	-	-	-	-	-	-	-	-	-	-	-	-	-	-	-	-	-	-	-
	SW04MB01	09-Mar-2012	-	-	-	-	-	-	-	-	-	-	-	-	-	-	-	-	-	-	-	-	-	-	-	-
	SW04MB01	23-Apr-2013	-	-	-	-	-	-	-	-	-	-	-	-	-	-	-	-	-	-	-	-	-	-	-	-
	SW04MB01	04-Dec-2013	-	-	-	-	-	-	-	-	-	-	-	-	-	-	-	-	-	-	-	-	-	-	-	-
	SW04MB01	02-Jun-2014	-	-	-	-	-	-	-	-	-	-	-	-	-	-	-	-	-	-	-	-	-	-	-	-
	SW04MB01	21-Jan-2015	-	-	-	-	-	-	-	-	-	-	-	-	-	-	-	-	-	-	-	-	-	-	-	-
	SW04MB01	19-Aug-2015	-	-	-	-	-	-	-	-	-	-	-	-	-	-	-	-	-	-	-	-	-	-	-	-
	SW04MB01	16-Feb-2016	-	-	-	-	-	-	-	-	-	-	-	-	-	-	-	-	-	-	-	-	-	-	-	-
	SW04MB01	27-Sep-2016	-	-	-	-	-	-	-	-	-	-	-	-	-	-	-	-	-	-	-	-	-	-	-	-
	SW04MB01	04-Apr-2017	-	-	-	-	-	-	-	-	-	-	-	-	-	-	-	-	-	-	-	-	-	-	-	-
	SW04MB01	27-Sep-2017	-	-	-	-	-	-	-	-	-	-	-	-	-	-	-	-	-	-	-	-	-	-	-	-
Job 125-Mt Todd Bore DEC-2013	SW04MB01	04-Dec-2013	<0.05	-	-	-	-	-	-	-	-	-	-	-	-	-	-	-	-	-	-	-	-	-	-	-
Job 140-Mt Todd Bore JUN-2014	SW04MB01	02-Jun-2014	<0.05	-	-	-	-	-	-	-	-	-	-	-	-	-	-	-	-	-	-	-	-	-	-	-
Job 171 - Mt Todd Bore FEB 2016	SW04MB01	16-Feb-2016	<0.05	-	-	-	-	-	-	-	-	-	-	-	-	-	-	-	-	-	-	-	-	-	-	-
Job 193 - Mt Todd Bore Sep 2016	SW04MB01	27-Sep-2016	-	<1	<1	22	85	<1	<0.5	<1	<0.5	120	130	110	<0.5	27	<0.1	<0.1	<1	2	2	<1	<1	2	<1	<1

Statistical Summary	Mercury	Antimony (Filtered)	Bismuth (Filtered)	Lithium (Filtered)	Strontium (Filtered)	Thallium (Filtered)	Thorium (Filtered)	Titanium (Filtered)	Uranium (Filtered)	Arsenic	Arsenic (Filtered)	Barium (Filtered)	Beryllium (Filtered)	Boron (Filtered)	Cadmium	Cadmium (Filtered)	Chromium (III+VI) (Filtered)	Cobalt	Cobalt (Filtered)	Copper	Copper (Filtered)	Molybdenum (Filtered)	Silver (Filtered)	Tin (Filtered)	
Number of Results	3	1	1	1	1	1	1	1	1	1	1	1	1	1	1	1	1	1	1	1	1	1	1	1	1
Number of Detects	0	0	0	1	1	0	0	0	0	1	1	1	0	1	0	0	0	1	1	0	0	1	0	0	
Minimum Concentration	<0.05	<1	<1	22	85	<1	<0.5	<1	<0.5	120	130	110	<0.5	27	<0.1	<0.1	<1	2	2	<1	<1	2	<1	<1	
Maximum Concentration	<0.05	<1	<1	22	85	<1	<0.5	<1	<0.5	120	130	110	<0.5	27	<0.1	<0.1	<1	2	2	<1	<1	2	<1	<1	
Median Concentration	0.025	0.5	0.5	22	85	0.5	0.25	0.5	0.25	120	130	110	0.25	27	0.05	0.05	0.5	2	2	0.5	0.5	2	0.5	0.5	
Standard Deviation	0																								

	Aluminium	Aluminium (Filtered)	Iron	Iron (Filtered)	Lead	Lead (Filtered)	Manganese	Manganese (Filtered)	Nickel	Nickel (Filtered)	Selenium (Filtered)	Zinc	Zinc (Filtered)	Vanadium (Filtered)	Antimony (Filtered)	Bismuth (Filtered)	Lithium (Filtered)	Strontium (Filtered)	Thallium (Filtered)	Thorium (Filtered)	Titanium (Filtered)	Uranium (Filtered)	Arsenic	Arsenic (Filtered)	Barium (Filtered)	Beryllium (Filtered)
	µg/L	µg/L	mg/L	mg/L	µg/L	µg/L	µg/L	µg/L	µg/L	µg/L	µg/L	µg/L	µg/L	µg/L	µg/L	µg/L	µg/L	µg/L	µg/L	µg/L	µg/L	µg/L	µg/L	µg/L	µg/L	µg/L
EQL	10	10	0.01	0.01	1	1	5	5	1	1	1	1	1	1	1	1	1	1	1	0.5	1	0.5	1	1	1	0.5
WDL 178-06		150		0.35		9.4		3600		17			31													140
WDL 178-06 x 2		300		0.7		18.8		7200		34			62													280

Field ID Location Code Sampled Date Time

	SW04MB01	07-Sep-2011	-	-	-	-	-	-	-	-	-	-	-	-	-	-	-	-	-	-	-	-	-	-	-	-	-
	SW04MB01	15-Dec-2011	-	-	-	-	-	-	-	-	-	-	-	-	-	-	-	-	-	-	-	-	-	-	-	-	-
	SW04MB01	09-Mar-2012	-	-	-	-	-	-	-	-	-	-	-	-	-	-	-	-	-	-	-	-	-	-	-	-	-
	SW04MB01	23-Apr-2013	-	-	-	-	-	-	-	-	-	-	-	-	-	-	-	-	-	-	-	-	-	-	-	-	-
	SW04MB01	04-Dec-2013	-	-	-	-	-	-	-	-	-	-	-	-	-	-	-	-	-	-	-	-	-	-	-	-	-
	SW04MB01	02-Jun-2014	-	-	-	-	-	-	-	-	-	-	-	-	-	-	-	-	-	-	-	-	-	-	-	-	-
	SW04MB01	21-Jan-2015	-	-	-	-	-	-	-	-	-	-	-	-	-	-	-	-	-	-	-	-	-	-	-	-	-
	SW04MB01	19-Aug-2015	-	-	-	-	-	-	-	-	-	-	-	-	-	-	-	-	-	-	-	-	-	-	-	-	-
	SW04MB01	16-Feb-2016	-	-	-	-	-	-	-	-	-	-	-	-	-	-	-	-	-	-	-	-	-	-	-	-	-
	SW04MB01	27-Sep-2016	-	-	-	-	-	-	-	-	-	-	-	-	-	-	-	-	-	-	-	-	-	-	-	-	-
	SW04MB01	04-Apr-2017	-	-	-	-	-	-	-	-	-	-	-	-	-	-	-	-	-	-	-	-	-	-	-	-	-
	SW04MB01	27-Sep-2017	-	-	-	-	-	-	-	-	-	-	-	-	-	-	-	-	-	-	-	-	-	-	-	-	-
Job 125-Mt Todd Bore DEC-2013	SW04MB01	04-Dec-2013	-	-	-	-	-	-	-	-	-	-	-	-	<1	<1	29	93	<1	<0.5	<1	<0.5	150	120	120	<0.5	
Job 140-Mt Todd Bore JUN-2014	SW04MB01	02-Jun-2014	-	-	-	-	-	-	-	-	-	-	-	-	<1	<1	24	87	<1	<0.5	<1	<0.5	86	94	120	<0.5	
Job 171 - Mt Todd Bore FEB 2016	SW04MB01	16-Feb-2016	-	-	-	-	-	-	-	-	-	-	-	-	<1	<1	6	21	<1	<0.5	<1	<0.5	16	11	37	<0.5	
Job 193 - Mt Todd Bore Sep 2016	SW04MB01	27-Sep-2016	<10	<10	0.62	0.54	<1	<1	280	290	2	1	<1	2	<1	<1	-	-	-	-	-	-	-	-	-	-	

Statistical Summary			Aluminium	Aluminium (Filtered)	Iron	Iron (Filtered)	Lead	Lead (Filtered)	Manganese	Manganese (Filtered)	Nickel	Nickel (Filtered)	Selenium (Filtered)	Zinc	Zinc (Filtered)	Vanadium (Filtered)	Antimony (Filtered)	Bismuth (Filtered)	Lithium (Filtered)	Strontium (Filtered)	Thallium (Filtered)	Thorium (Filtered)	Titanium (Filtered)	Uranium (Filtered)	Arsenic	Arsenic (Filtered)	Barium (Filtered)	Beryllium (Filtered)	
Number of Results			1	1	1	1	1	1	1	1	1	1	1	1	1	1	3	3	3	3	3	3	3	3	3	3	3	3	3
Number of Detects			0	0	1	1	0	0	1	1	1	1	0	1	0	0	0	0	3	3	0	0	0	0	3	3	3	0	
Minimum Concentration			<10	<10	0.62	0.54	<1	<1	280	290	2	1	<1	2	<1	<1	<1	<1	6	21	<1	<0.5	<1	<0.5	16	11	37	<0.5	
Maximum Concentration			<10	<10	0.62	0.54	<1	<1	280	290	2	1	<1	2	<1	<1	<1	<1	29	93	<1	<0.5	<1	<0.5	150	120	120	<0.5	
Median Concentration			5	5	0.62	0.54	0.5	0.5	280	290	2	1	0.5	2	0.5	0.5	0.5	0.5	24	87	0.5	0.25	0.5	0.25	86	94	120	0.25	
Standard Deviation																	0	0	12	40	0	0	0	0	67	57	48	0	

Metals-022 ICP-MS

	Boron (Filtered)	Cadmium	Cadmium (Filtered)	Chromium (III+VI) (Filtered)	Cobalt	Cobalt (Filtered)	Copper	Copper (Filtered)	Molybdenum (Filtered)	Silver (Filtered)	Tin (Filtered)	Aluminium	Aluminium (Filtered)	Iron	Iron (Filtered)	Lead	Lead (Filtered)	Manganese	Manganese (Filtered)	Nickel	Nickel (Filtered)	Selenium (Filtered)	Zinc	Zinc (Filtered)	Vanadium (Filtered)
	µg/L	µg/L	µg/L	µg/L	µg/L	µg/L	µg/L	µg/L	µg/L	µg/L	µg/L	µg/L	µg/L	mg/L	mg/L	µg/L	µg/L	µg/L	µg/L	µg/L	µg/L	µg/L	µg/L	µg/L	µg/L
EQL	5	0.1	0.1	1	1	1	1	1	1	1	1	10	10	0.01	0.01	1	1	5	5	1	1	1	1	1	1
WDL 178-06			0.8			13		2.5					150		0.35		9.4		3600		17			31	
WDL 178-06 x 2			1.6			26		5					300		0.7		18.8		7200		34			62	

Field ID Location Code Sampled Date Time

	SW04MB01	07-Sep-2011	-	-	-	-	-	-	-	-	-	-	-	-	-	-	-	-	-	-	-	-	-	-	-		
	SW04MB01	15-Dec-2011	-	-	-	-	-	-	-	-	-	-	-	-	-	-	-	-	-	-	-	-	-	-	-		
	SW04MB01	09-Mar-2012	-	-	-	-	-	-	-	-	-	-	-	-	-	-	-	-	-	-	-	-	-	-	-		
	SW04MB01	23-Apr-2013	-	-	-	-	-	-	-	-	-	-	-	-	-	-	-	-	-	-	-	-	-	-	-		
	SW04MB01	04-Dec-2013	-	-	-	-	-	-	-	-	-	-	-	-	-	-	-	-	-	-	-	-	-	-	-		
	SW04MB01	02-Jun-2014	-	-	-	-	-	-	-	-	-	-	-	-	-	-	-	-	-	-	-	-	-	-	-		
	SW04MB01	21-Jan-2015	-	-	-	-	-	-	-	-	-	-	-	-	-	-	-	-	-	-	-	-	-	-	-		
	SW04MB01	19-Aug-2015	-	-	-	-	-	-	-	-	-	-	-	-	-	-	-	-	-	-	-	-	-	-	-		
	SW04MB01	16-Feb-2016	-	-	-	-	-	-	-	-	-	-	-	-	-	-	-	-	-	-	-	-	-	-	-		
	SW04MB01	27-Sep-2016	-	-	-	-	-	-	-	-	-	-	-	-	-	-	-	-	-	-	-	-	-	-	-		
	SW04MB01	04-Apr-2017	-	-	-	-	-	-	-	-	-	-	-	-	-	-	-	-	-	-	-	-	-	-	-		
	SW04MB01	27-Sep-2017	-	-	-	-	-	-	-	-	-	-	-	-	-	-	-	-	-	-	-	-	-	-	-		
Job 125-Mt Todd Bore DEC-2013	SW04MB01	04-Dec-2013	24	<0.1	<0.1	<1	2	1	<1	<1	3	<1	<1	<10	<10	1.2	0.98	<1	<1	500	410	2	1	<1	<1	<1	<1
Job 140-Mt Todd Bore JUN-2014	SW04MB01	02-Jun-2014	21	<0.1	<0.1	<1	1	<1	3	3	2	<1	<1	50	<10	0.76	0.67	<1	<1	310	400	1	1	<1	9	2	<1
Job 171 - Mt Todd Bore FEB 2016	SW04MB01	16-Feb-2016	12	<0.1	<0.1	<1	<1	<1	2	<1	<1	<1	<1	340	<10	0.3	0.012	<1	<1	38	36	2	1	<1	2	2	<1
Job 193 - Mt Todd Bore Sep 2016	SW04MB01	27-Sep-2016	-	-	-	-	-	-	-	-	-	-	-	-	-	-	-	-	-	-	-	-	-	-	-	-	

Statistical Summary																											
Number of Results			3	3	3	3	3	3	3	3	3	3	3	3	3	3	3	3	3	3	3	3	3	3	3	3	
Number of Detects			3	0	0	0	2	1	2	1	2	0	0	2	0	3	3	0	0	3	3	3	3	0	2	2	0
Minimum Concentration			12	<0.1	<0.1	<1	<1	<1	<1	<1	<1	<1	<1	<10	<10	0.3	0.012	<1	<1	38	36	1	1	<1	<1	<1	<1
Maximum Concentration			24	<0.1	<0.1	<1	2	1	3	3	3	<1	<1	340	<10	1.2	0.98	<1	<1	500	410	2	1	<1	9	2	<1
Median Concentration			21	0.05	0.05	0.5	1	0.5	2	0.5	2	0.5	0.5	50	5	0.76	0.67	0.5	0.5	310	400	2	1	0.5	2	2	0.5
Standard Deviation			6.2	0	0	0	0.76	0.29	1.3	1.4	1.3	0	0	182	0	0.45	0.49	0	0	232	213	0.58	0	0	4.5	0.87	0

	UNK	
	Anions Total	Cations Total
	meq/L	meq/L
EQL	0	0
WDL 178-06		
WDL 178-06 x 2		

Field ID Location Code Sampled Date Time

	SW04MB01	07-Sep-2011	-	-
	SW04MB01	15-Dec-2011	-	-
	SW04MB01	09-Mar-2012	-	-
	SW04MB01	23-Apr-2013	-	-
	SW04MB01	04-Dec-2013	-	-
	SW04MB01	02-Jun-2014	-	-
	SW04MB01	21-Jan-2015	-	-
	SW04MB01	19-Aug-2015	-	-
	SW04MB01	16-Feb-2016	-	-
	SW04MB01	27-Sep-2016	-	-
	SW04MB01	04-Apr-2017	-	-
	SW04MB01	27-Sep-2017	-	-
Job 125-Mt Todd Bore DEC-2013	SW04MB01	04-Dec-2013	-	-
Job 140-Mt Todd Bore JUN-2014	SW04MB01	02-Jun-2014	-	-
Job 171 - Mt Todd Bore FEB 2016	SW04MB01	16-Feb-2016	-	-
Job 193 - Mt Todd Bore Sep 2016	SW04MB01	27-Sep-2016	2	2.52

Statistical Summary					
Number of Results			1	1	
Number of Detects			1	1	
Minimum Concentration			2	2.52	
Maximum Concentration			2	2.52	
Median Concentration			2	2.52	
Standard Deviation					

Appendix P2

Water Extraction Licence



NORTHERN TERRITORY OF AUSTRALIA
LICENCE TO TAKE OR USE SURFACE WATER
Pursuant to section 45 of the *Water Act 1992*

Licence No: 8141014

Licence Holder:	Vista Gold Australia Pty Ltd (ACN 117 327 509)		
Address:	PO Box 3449 Darwin NT		
Commencement Date:	1 June 2021		
Expiry Date:	1 June 2031		
Water Control District:	Daly Roper Beetaloo		
Management Zone:	Not applicable		
Water Allocation Plan:	Not applicable		
River Basin:	Daly River		
Waterway:	Horseshoe Creek		
Location of extraction point(s):	190311E; 8436850N (Zone 53; GDA94)		
Property(s) on which water is used:	NT Portion 4367		
Beneficial Use(s) of Water Entitlement	Maximum Water Entitlement ML/year	Security Level	Licence Trading Allowed?
Mining Activity	3480	Not Specified	N/A
Total Maximum Water Entitlement:	3480 ML/year		

Terms and Conditions:

1 General Conditions

- 1.1 The licence holder must comply with the provisions of the Act and all other laws in force in the Territory, including all regulations made under the Act.
- 1.2 The licence holder may surrender or apply for modification of this licence at any time.
- 1.3 The Controller may amend, revoke, suspend or modify this licence at any time, as provided for in section 93 of the Act.
- 1.4 Subject to Conditions 1.2 and 1.3, this licence is in force until the expiry date.

2 Water Extraction Conditions

- 2.1 The licence holder must extract no more than the stated Total Maximum Water Entitlement from the listed Waterway.
- 2.2 Subject to Conditions 2.3 and 2.4, the licence holder must ensure that total extraction from the listed Waterway over the Periods specified below does not exceed the following Entitlements:

Period	Entitlement
1 June 2021 to 30 April 2022	3192 ML
1 May 2021 to 30 April 2022	3480 ML



1 May 2022 to 30 April 2023	3480 ML
1 May 2023 to 30 April 2024	3480 ML
1 May 2024 to 30 April 2025	3480 ML
1 May 2025 to 30 April 2026	3480 ML
1 May 2026 to 30 April 2027	3480 ML
1 May 2027 to 30 April 2028	3480 ML
1 May 2028 to 30 April 2029	3480 ML
1 May 2029 to 30 April 2030	3480 ML
1 May 2030 to 30 April 2031	3480 ML
1 May 2031 to 1 June 2031	290 ML

- 2.3 In each Period the licence holder must ensure that total extraction from the listed Waterway does not exceed the Extraction Limit, which is determined as follows:
Extraction Limit (ML/yr) = Entitlement (ML) x Announced Allocation (%)
- 2.4 The licence holder must not extract more than the Monthly Extraction Limit from the listed Waterway in any one calendar month without the prior written approval of the Controller.
- 2.5 The licensee must ensure water extracted under this licence is not wasted.
For the purposes of this condition water is wasted where, irrespective of intention:
(a) more water is used than is reasonably necessary for the immediate purpose for which water is taken, including used for irrigation;
(b) an unnecessary or excessive flow or flood of water is allowed to occur; or
(c) water is taken without adequate control or supervision of its taking.
- 2.6 The Maximum Water Entitlement must be used for no purpose other than that beneficial use without the prior written approval of the Controller.
- 2.7 The licence holder may only extract water under this licence from an extraction point listed on this licence.
- 2.8 The licence holder may only extract water under this licence for use on a property listed on this licence.
- 3 Water Metering and Reporting Conditions**
- 3.1 Extraction from the listed Waterway must be recorded by a meter or meters supplied, installed and maintained by the licence holder in accordance with the Northern Territory Non-Urban Water Metering Code of Practice for Water Extraction Licences, as amended from time to time.
- 3.2 Within two (2) weeks following the end of each Quarter, the licence holder must supply the Controller with a record of total extraction from each of the listed extraction point(s) during that Quarter, reportable by calendar month.
- 4 Trading Conditions**
- 4.1 The licence holder may only trade the Entitlements under this licence in accordance with a Water Allocation Plan.
- 4.2 The obligations under this licence remain with the licence holder unless and until the Entitlements under this licence are traded in accordance with a Water Allocation Plan.
- 5 Special Conditions**
- 5.1 If there is a conflict between the terms and conditions of this licence and the special conditions listed below, the special conditions will prevail to the extent of the inconsistency.
- 5.2 The licence holder may only extract water under this licence for Approved Mining Activities.
- 5.3 The licence holder must provide a written report to the Controller within forty-eight hours of identifying any contravention of the terms and conditions of this licence, including the special conditions. The written report must set out:



- (a) comprehensive details of the contravention; and
 - (b) how the licence holder proposes to rectify the contravention and prevent the contravention from reoccurring.
- 5.4 The licence holder must have in place a Mining Management Plan to conduct Approved Mining Activities, approved by the Minister in accordance with the Mining Management Act 2001 throughout the term of this licence. If the Mining Management Plan is revoked, the Controller may, by notice in writing served on the licence holder, revoke this licence or suspend this licence for such period as is specified in the notice.
- 5.5 Within 2 weeks of 30 June of each year, the licence holder must provide an annual report to Water Resources Division. The report must include:
- (a) Details of the licence holders compliance with the conditions of the Licence for the previous Water Year;
 - (b) A comparison of the volume of water taken between the previous water year and current water year, noting any discrepancies between projected and actual water use, with an explanation for the difference, where appropriate.
 - (c) Detail on any water saving measures implemented during the 12 months to June, and information on any planned water savings measures for the upcoming 12 months.
- 5.6 Without limiting the Controller's powers pursuant to s93 of the Act, the Controller may reduce the Total Maximum Water Entitlement conferred by this licence after consideration of any report or projection provided by the licence holder as required by condition 5.3



Joanne Townsend

Controller of Water Resources

11/6/2021

Definitions

"Act" means the *Water Act 1992* (NT).

"Announced Allocation" means the factor by which the Entitlements shown in Condition 2.2 must be adjusted. It is either:

- (a) The percentage allocation for the relevant Period notified to the licence holder in writing by the Controller, or
- (b) If no such percentage is notified, 100%.

"Approved Mining Activities" means a mining activity or activities that have been approved by the Minister in accordance with the Mining Management Act 2001.

"Controller" means the Controller of Water Resources.

"Entitlement" means the amount(s) specified in Condition 2.2.

"Extraction Limit" means the quantity of water calculated according to the formula in Condition 2.3.

"Minimum Extraction Limit" means the percentage of the Extraction Limit that is either:

- (a) If a percentage is set out in a relevant Water Allocation Plan, that percentage, or
- (b) Otherwise, 90%.

"Monthly Extraction Limit" means the percentage of the Extraction Limit that is either:

- (a) If a percentage is set out in a relevant Water Allocation Plan, that percentage, or
- (b) Otherwise, 30%.



"Period" means a period of time specified in Condition 2.2.

"Quarter" means each period of 3 months ending on 30 June, 30 September, 31 December and 31 March during the Term of the Licence (or part of the Quarter occurring at the beginning or end of the term).

"Regulations" means the *Water Regulations 1992* (NT).





"Security level" means the order in which announced allocations are applied to licences. E.g. in years when a less than 100% announced allocation is required to ensure that environmental water provisions are satisfied, Low Security licence entitlements are reduced first, then Medium Security entitlements and finally High Security entitlements.



www.mttodd.com.au

File Name: *Attachment R8-Water Management Plan.pdf.docx*

Document Status

Revision	Author	Reviewer		Approved for Issue		
		Name	Signature	Name	Signature	Date
REV 0	James Hill	Jill Woodworth		Jill Woodworth		17/11/2017
REV 1	Brent Murdoch	John Rozelle		Brent Murdoch		31/10/2018
REV 2	Colin Davis Jill Woodworth	Jesse Pottage		Brent Murdoch		28/05/2020
Rev 3.1	Jill Woodworth	Brent Murdoch		Brent Murdoch		11/01/2022
Rev 3.2	Brent Murdoch	John Rozelle		Brent Murdoch		22/05/2022